

SEMESTER II

SLOT	COURSE NO.	COURSES	L-T-P	HOURS	CREDIT
A	MAT 102	VECTOR CALCULUS, DIFFERENTIAL EQUATIONS AND TRANSFORMS	3-1-0	4	4
B	CYT 100	ENGINEERING CHEMISTRY	3-1-0	4	4
C	EST 100	ENGINEERING MECHANICS	2-1-0	3	3
D	EST 130	BASICS OF ELECTRICAL & ELECTRONICS ENGINEERING	4-0-0	4	4
E	HUT 102	PROFESSIONAL COMMUNICATION	2-0-2	4	--
F	EST 102	PROGRAMMING IN C	2-1-2	5	4
S	CYL 120	ENGINEERING CHEMISTRY LAB	0-0-2	2	1
T	ESL 130	ELECTRICAL & ELECTRONICS WORKSHOP	0-0-2	2	1
TOTAL				28/29	21

MAT 102	VECTOR CALCULUS, DIFFERENTIAL EQUATIONS AND TRANSFORMS	CATEGORY	L	T	P	CREDIT	Year of Introduction
		BSC	3	1	0	4	2019

Preamble: This course introduces the concepts and applications of differentiation and integration of vector valued functions, differential equations, Laplace and Fourier Transforms. The objective of this course is to familiarize the prospective engineers with some advanced concepts and methods in Mathematics which include the Calculus of vector valued functions, ordinary differential equations and basic transforms such as Laplace and Fourier Transforms which are invaluable for any engineer's mathematical tool box. The topics treated in this course have applications in all branches of engineering.

Prerequisite: Calculus of single and multi variable functions.

Course Outcomes: After the completion of the course the student will be able to

CO 1	Compute the derivatives and line integrals of vector functions and learn their applications
CO 2	Evaluate surface and volume integrals and learn their inter-relations and applications.
CO 3	Solve homogeneous and non-homogeneous linear differential equation with constant coefficients
CO 4	Compute Laplace transform and apply them to solve ODEs arising in engineering
CO 5	Determine the Fourier transforms of functions and apply them to solve problems arising in engineering

Mapping of course outcomes with program outcomes

	PO 1	PO 2	PO 3	PO 4	PO 5	PO 6	PO 7	PO 8	PO 9	PO 10	PO 11	PO 12
CO 1	3	3	3	3	2	1			1	2		2
CO 2	3	3	3	3	2	1			1	2		2
CO 3	3	3	3	3	2	1			1	2		2
CO 4	3	3	3	3	2	1			1	2		2
CO 5	3	3	3	3	2	1			1	2		2

Assessment Pattern

Bloom's Category	Continuous Assessment Tests		End Semester Examination (Marks)
	Test 1 (Marks)	Test 2 (Marks)	
Remember	10	10	20
Understand	20	20	40
Apply	20	20	40
Analyse			
Evaluate			

Create			
--------	--	--	--

Mark distribution

Total Marks	CIE (Marks)	ESE (Marks)	ESE Duration
150	50	100	3 hours

Continuous Internal Evaluation Pattern:

Attendance : 10 marks

Continuous Assessment Test (2 numbers) : 25 marks

Assignment/Quiz/Course project : 15 marks

Assignments: Assignment should include specific problems highlighting the applications of the methods introduced in this course in science and engineering.

End Semester Examination Pattern: There will be two parts; Part A and Part B. Part A contain 10 questions with 2 questions from each module, having 3 marks for each question. Students should answer all questions. Part B contains 2 questions from each module of which student should answer only one. Each question can have maximum 2 sub-divisions and carry 14 marks.

Course Level Assessment Questions

Course Outcome 1 (CO1): Compute the derivatives and line integrals of vector functions and learn their applications

1. How would you calculate the speed, velocity and acceleration at any instant of a particle moving in space whose position vector at time t is $\mathbf{r}(t)$?
2. Find the work done by the force field $F = (e^x - y^3)\mathbf{i} + (\cos y + x^3)\mathbf{j}$ on a particle that travels once around the unit circle centred at origin having radius 1.
3. When do you say that a vector field is conservative? What are the implications if a vector field is conservative?

Course Outcome 2 (CO2): Evaluate surface and volume integrals and learn their inter-relations and applications

1. Write any one application each of line integral, double integral and surface integral.
2. Use the divergence theorem to find the outward flux of the vector field $F(x, y, z) = z\mathbf{k}$ across the

$$x^2 + y^2 + z^2 = a^2$$

3. State Greens theorem. Use Green's theorem to express the area of a plane region bounded by a curve as a line integral.

Course Outcome 3 (CO3): Solve homogeneous and non-homogeneous linear differential equation with constant coefficients

1. If $y_1(x)$ and $y_2(x)$ are solutions of $y'' + py' + qy = 0$, where p, q are constants, show that

$y_1(x) + y_2(x)$ is also a solution.

2. Solve the differential equation $y'' + y = 0.001x^2$ using method of undetermined coefficient.

3. Solve the differential equation of $y''' - 3y'' + 3y' - y = e^x - x - 1$.

Course Outcome 4 (CO4): Compute Laplace transform and apply them to solve ODEs arising in engineering

1. What is the inverse Laplace Transform of $(s) = \frac{3s-137}{s^2+2s+4}$?

2. Find Laplace Transform of Unit step function.

3. Solve the differential equation of $y'' + 9y = \delta\left(t - \frac{\pi}{2}\right)$? Given $y(0) = 2, y'(0) = 0$

Course Outcome 5 (CO5): Determine the Fourier transforms of functions and apply them to solve problems arising in engineering

1. Find the Fourier integral representation of function defined by

$$f(x) = e^{-x} \text{ for } x > 0 \text{ and } f(x) = 0 \text{ for } x < 0.$$

2. What are the conditions for the existence of Fourier Transform of a function $f(x)$?

3. Find the Fourier transform of $f(x) = 1$ for $|x| < 1$ and $f(x) = 0$ otherwise.

Model Question paper

QP CODE:

PAGES:3

Reg No: _____

Name : _____

**APJ ABDUL KALAM TECHNOLOGICAL UNIVERSITY FIRST SEMESTER B.TECH DEGREE EXAMINATION,
MONTH & YEAR**

Course Code: MAT 102

Max. Marks: 100

Duration: 3 Hours

VECTOR CALCULUS, DIFFERENTIAL EQUATIONS AND TRANSFORMS

(2019-Scheme)

(Common to all branches)

PART A

(Answer all questions. Each question carries 3 marks)

1. Is the vector \mathbf{r} where $\mathbf{r} = x\mathbf{i} + y\mathbf{j} + z\mathbf{k}$ conservative. Justify your answer.
2. State Greens theorem including all the required hypotheses
3. What is the outward flux of $\mathbf{F}(x, y, z) = x\mathbf{i} + y\mathbf{j} + z\mathbf{k}$ across any unit cube.
4. What is the relationship between Green's theorem and Stokes theorem?
5. Solve $y'' + 4y' + 2.5y = 0$
6. Does the function $y = C_1 \cos x + C_2 \sin x$ form a solution of $y'' + y = 0$? Is it the general solution? Justify your answer.
7. Find the Laplace transform of $e^{-t} \sinh 4t$
8. Find the Laplace inverse transform of $\frac{1}{s(s^2 + \omega^2)}$.
9. Given the Fourier transform $\frac{1}{\sqrt{2}} e^{-\frac{\omega^2}{4}}$ of $f(x) = e^{-x^2}$, find the Fourier transform of xe^{-x^2}
10. State the convolution theorem for Fourier transform

PART B

(Answer one full question from each module. Each full question carries 14 marks)

MODULE 1

11a) Prove that the force field $\mathbf{F} = e^y\mathbf{i} + xe^y\mathbf{j}$ is conservative in the entire xy -plane

b) Use Greens theorem to find the area enclosed by the ellipse $\frac{x^2}{a^2} + \frac{y^2}{b^2} = 1$

12 a) Find the divergence of the vector field $\mathbf{F} = \frac{c}{(x^2 + y^2 + z^2)^{3/2}} (x\mathbf{i} + y\mathbf{j} + z\mathbf{k})$

b) Find the work done by the force field $\mathbf{F}(x, y, z) = xy\mathbf{i} + yz\mathbf{j} + xz\mathbf{k}$ along C where

C is the curve $\mathbf{r}(t) = t\mathbf{i} + t^2\mathbf{j} + t^3\mathbf{k}$

MODULE II

13 a) Use divergence theorem to find the outward flux of the vector field

$\mathbf{F} = 2x\mathbf{i} + 3y\mathbf{j} + z^3\mathbf{k}$ across the unit cube bounded by or $x = 0, y = 0, z = 0, x = 1, y = 1, z = 1$

b) Find the circulation of $\mathbf{F} = (x - z)\mathbf{i} + (y - x)\mathbf{j} + (z - xy)\mathbf{k}$ using Stokes theorem around the triangle with vertices $A(1,0,0), B(0,2,0)$ and $C(0,0,1)$

14 a) Use divergence theorem to find the volume of the cylindrical solid bounded

by $x^2 + 4x + y^2 = 7, z = -1, z = 4$, given the vector field $\mathbf{F} = x\mathbf{i} + y\mathbf{j} + z\mathbf{k}$ across surface of the cylinder

b) Use Stokes theorem to evaluate $\int_C \mathbf{F} \cdot d\mathbf{r}$ where $\mathbf{F} = x^2\mathbf{i} + 3x\mathbf{j} - y^3\mathbf{k}$ where C is

the circle $x^2 + y^2 = 1$ in the xy - plane with counterclockwise orientation looking down the positive z -axis

MODULE III

- 15 a) Solve $y'' + 4y' + 4y = x^2 + e^{-x} \cos x$
b) Solve $y''' - 3y'' + 3y' - y = e^x - x - 1$
16 a) Solve $y'''' + 3y'' + 3y' + y = 30e^{-x}$ given $y(0) = 3, y'(0) = -3, y''(0) = -47$
b) Using method of variation of parameters, solve $y'' + y = \sec x$

MODULE IV

- 17 a) Find the inverse Laplace transform of $F(s) = \frac{2(e^{-s} - e^{-3s})}{s^2 - 4}$
b) Solve the differential equation $y'' + 16y = 4\delta(t - 3\pi); y(0) = 2, y'(0) = 0$ using Laplace transform
18 a) Solve $y'' + 3y' + 2y = f(t)$ where $f(t) = 1$ for $0 < t < 1$ and $f(t) = 1$ for $t > 1$ using Laplace transform
b) Apply convolution theorem to find the Laplace inverse transform of $\frac{1}{s^2(s^2 + \omega^2)}$

MODULE V

- 19 a) Find the Fourier cosine integral representation for $f(x) = e^{-kx}$ for $x > 0$ and $k > 0$ and hence evaluate $\int_0^\infty \frac{\cos wx}{k^2 + w^2}$ the function
b) Does the Fourier sine transform $f(x) = x^{-1} \sin x$ for $0 < x < \infty$ exist? Justify your answer
20 a) Find the Fourier transform of $f(x) = |x|$ for $|x| < 1$ and $f(x) = 0$ otherwise
b) Find the Fourier cosine transform of $f(x) = e^{-ax}$ for $a > 0$

Syllabus

Module 1 (Calculus of vector functions)

(Text 1: Relevant topics from sections 12.1, 12.2, 12.6, 13.6, 15.1, 15.2, 15.3)

Vector valued function of single variable, derivative of vector function and geometrical interpretation, motion along a curve-velocity, speed and acceleration. Concept of scalar and vector fields, Gradient and its properties, directional derivative, divergence and curl, Line integrals of vector fields, work as line integral, Conservative vector fields, independence of path and potential function (results without proof).

Module 2 (Vector integral theorems)

(Text 1: Relevant topics from sections 15.4, 15.5, 15.6, 15.7, 15.8)

Green's theorem (for simply connected domains, without proof) and applications to evaluating line integrals and finding areas. Surface integrals over surfaces of the form $z = g(x, y)$, $y = g(x, z)$ or $x = g(y, z)$, Flux integrals over surfaces of the form $z = g(x, y)$, $y = g(x, z)$ or $x = g(y, z)$, divergence theorem (without proof) and its applications to finding flux integrals, Stokes' theorem (without proof) and its applications to finding line integrals of vector fields and work done.

Module- 3 (Ordinary differential equations)

(Text 2: Relevant topics from sections 2.1, 2.2, 2.5, 2.6, 2.7, 2.10, 3.1, 3.2, 3.3)

Homogenous linear differential equation of second order, superposition principle, general solution, homogenous linear ODEs with constant coefficients-general solution. Solution of Euler-Cauchy equations (second order only). Existence and uniqueness (without proof). Non homogenous linear ODEs-general solution, solution by the method of undetermined coefficients (for the right hand side of the form $x^n, e^{kx}, \sin ax, \cos ax, e^{kx} \sin ax, e^{kx} \cos ax$ and their linear combinations), methods of variation of parameters. Solution of higher order equations-homogeneous and non-homogeneous with constant coefficient using method of undetermined coefficient.

Module- 4 (Laplace transforms)

(Text 2: Relevant topics from sections 6.1, 6.2, 6.3, 6.4, 6.5)

Laplace Transform and its inverse, Existence theorem (without proof), linearity, Laplace transform of basic functions, first shifting theorem, Laplace transform of derivatives and integrals, solution of differential equations using Laplace transform, Unit step function, Second shifting theorems. Dirac delta function and its Laplace transform, Solution of ordinary differential equation involving unit step function and Dirac delta functions. Convolution theorem (without proof) and its application to finding inverse Laplace transform of products of functions.

Module-5 (Fourier Transforms)

(Text 2: Relevant topics from sections 11.7,11.8, 11.9)

Fourier integral representation, Fourier sine and cosine integrals. Fourier sine and cosine transforms, inverse sine and cosine transform. Fourier transform and inverse Fourier transform, basic properties. The Fourier transform of derivatives. Convolution theorem (without proof)

Text Books

1. H. Anton, I. Biven S.Davis, "Calculus", Wiley, 10th edition, 2015.
2. Erwin Kreyszig, "Advanced Engineering Mathematics", Wiley, 10th edition, 2015.

Reference Books

1. J. Stewart, Essential Calculus, Cengage, 2nd edition, 2017
2. G.B. Thomas and R.L. Finney, Calculus and Analytic geometry, 9th Edition, Pearson, Reprint, 2002.
3. Peter O Neil, Advanced Engineering Mathematics, 7th Edition, Thomson, 2007.
4. Louis C Barret, C Ray Wylie, "Advanced Engineering Mathematics", Tata McGraw Hill, 6th edition, 2003.
5. VeerarajanT."Engineering Mathematics for first year", Tata McGraw - Hill, 2008.
6. B.S. Grewal, Higher Engineering Mathematics, Khanna Publishers, 36th edition , 2010.
7. Srimanta Pal, Subodh C. Bhunia, "Engineering Mathematics", Oxford University Press, 2015.
8. Ronald N. Bracewell, "The Fourier Transform and its Applications", McGraw – Hill International Editions, 2000.

Course Contents and Lecture Schedule

No	Topic	No. of Lectures
1	Calculus of vector functions (9 hours)	
1.1	Vector valued function of a scalar variable - derivative of vector valued function of scalar variable t-geometrical meaning	2
1.2	Motion along a curve-speed , velocity, acceleration	1
1.3	Gradient and its properties, directional derivative , divergent and curl	3
1.4	Line integrals with respect to arc length, line integrals of vector fields. Work done as line integral	2
1.5	Conservative vector field, independence of path, potential function	1

2	Vector integral theorems(9 hours)	
2.1	Green's theorem and it's applications	2
2.2	Surface integrals , flux integral and their evaluation	3
2.3	Divergence theorem and applications	2
2.4	Stokes theorem and applications	2
3	Ordinary Differential Equations (9 hours)	
3.1	Homogenous linear equation of second order, Superposition principle, general solution	1
3.2	Homogenous linear ODEs of second order with constant coefficients	2
3.3	Second order Euler-Cauchy equation	1
3.4	Non homogenous linear differential equations of second order with constant coefficient-solution by undetermined coefficients, variation of parameters.	3
3.5	Higher order equations with constant coefficients	2
4	Laplace Transform (10 hours)	
4.1	Laplace Transform , inverse Transform, Linearity, First shifting theorem, transform of basic functions	2
4.2	Transform of derivatives and integrals	1
4.3	Solution of Differential equations, Initial value problems by Laplace transform method.	2
4.4	Unit step function --- Second shifting theorem	2
4.5	Dirac Delta function and solution of ODE involving Dirac delta function	2
4.6	Convolution and related problems.	1
5	Fourier Transform (8 hours)	
5.1	Fourier integral representation	1
5.2	Fourier Cosine and Sine integrals and transforms	2
5.3	Complex Fourier integral representation, Fourier transform and its inverse transforms, basic properties	3
5.4	Fourier transform of derivatives, Convolution theorem	2

APJ ABUL KALAM
TECHNOLOGICAL
UNIVERSITY

KTU



CYT 100	ENGINEERING CHEMISTRY	CATEGORY	L	T	P	CREDIT	YEAR OF INTRODUCTION
		BSC	3	1	0	4	2019

Preamble: To enable the students to acquire knowledge in the concepts of chemistry for engineering applications and to familiarize the students with different application oriented topics like spectroscopy, electrochemistry, instrumental methods etc. Also familiarize the students with topics like mechanism of corrosion, corrosion prevention methods, SEM, stereochemistry, polymers, desalination etc., which enable them to develop abilities and skills that are relevant to the study and practice of chemistry.

Prerequisite: Concepts of chemistry introduced at the plus two levels in schools

Course outcomes: After the completion of the course the students will be able to

CO 1	Apply the basic concepts of electrochemistry and corrosion to explore its possible applications in various engineering fields.
CO 2	Understand various spectroscopic techniques like UV-Visible, IR, NMR and its applications.
CO 3	Apply the knowledge of analytical method for characterizing a chemical mixture or a compound. Understand the basic concept of SEM for surface characterisation of nanomaterials.
CO 4	Learn about the basics of stereochemistry and its application. Apply the knowledge of conducting polymers and advanced polymers in engineering.
CO 5	Study various types of water treatment methods to develop skills for treating wastewater.

Mapping of course outcomes with program outcomes

	PO 1	PO 2	PO 3	PO 4	PO 5	PO 6	PO 7	PO 8	PO 9	PO 10	PO 11	PO 12
CO 1	1	2	1									
CO 2	1	1		1	2							
CO 3	1	1		1	2							
CO 4	2	1										
CO 5	1			1			3					

Assessment Pattern

Bloom's Category	Continuous Assessment Tests		End Semester Examination
	1	2	
Remember	15	15	30
Understand	25	25	50
Apply	10	10	20
Analyse			
Evaluate			
Create			

End Semester Examination Pattern: There will be two parts- **Part A** and **Part B**. **Part A** contains **10** questions (**2** questions from each module), having **3** marks for each question. Students should answer **all** questions. **Part B** contains **2** questions from each module, of which student should answer any one. Each question can have maximum **2** subdivisions and carries **14** marks.

Course Level Assessment Questions

Course Outcome 1 (CO 1):

1. What is calomel electrode? Give the reduction reaction (3 Marks)
2. List three important advantages of potentiometric titration (3 Marks)
3. (a) Explain how electroless plating copper and nickel are carried out (10 Marks)
(b) Calculate the emf of the following cell at 30°C, $Zn / Zn^{2+} (0.1M) // Ag^+ (0.01M) // Ag$.
Given $E^0 Zn^{2+}/Zn = -0.76 V$, $E^0 Ag^+/Ag = 0.8 V$. (4 Marks)

Course Outcome 2 (CO 2)

1. State Beer Lambert's law (3 Marks)
2. List the important applications of IR spectroscopy (3 Marks)
3. (a) What is Chemical shift? What are factors affecting Chemical shift? How 1H NMR spectrum of CH_3COCH_2Cl interpreted using the concept of chemical shift. (10 Marks)
(b) Calculate the force constant of HF molecule, if it shows IR absorption at 4138 cm^{-1} . Given that atomic masses of hydrogen and fluorine are 1u and 19u respectively. (4 Marks)

Course Outcome 3 (CO 3):

1. Distinguish between TGA and DTA (3 Marks)
2. Give two differences between GSC and GLC (3 Marks)

3. (a) Explain the principle, instrumentation and procedure of HPLC (10 Marks)

(b) Interpret TGA of $\text{CaC}_2\text{O}_4 \cdot \text{H}_2\text{O}$ (4 Marks)

Course Outcome 4 (CO 4):

1. Explain the geometrical isomerism in double bonds (3 Marks)

2. What are the rules of assigning R-S notation? (3 Marks)

3. (a) What are conducting polymers? How it is classified? Give the preparation of polyaniline (10 Marks)

(b) Draw the stereoisomers possible for $\text{CH}_3\text{-(CHOH)}_2\text{-COOH}$ (4 Marks)

Course Outcome 5 (CO 5):

1. What is degree of hardness? (3 Marks)

2. Define BOD and COD (3 Marks)

3. (a) Explain the EDTA estimation of hardness (10 Marks)

(b) Standard hard water contains 20 g of CaCO_3 per liter, 50 mL of this required 30 mL of EDTA solution, 50 mL of sample water required 20 mL of EDTA solution. 50 mL sample water after boiling required 14 mL EDTA solution. Calculate the temporary hardness of the given sample of water, in terms of ppm. (4 Marks)

MODEL QUESTION PAPER

Total Pages:

Reg No.: _____

Name: _____

APJ ABDUL KALAM TECHNOLOGICAL UNIVERSITY
FIRST SEMESTER B.TECH DEGREE EXAMINATION

Course Code: CYT100,

Course Name: ENGINEERING CHEMISTRY

Max. Marks: 100

Duration: 3 Hours

PART A

Answer all questions, each carries 3 marks

- | | | Marks |
|---|------------------------------------------------------------------------------------------------------------------------------------------------------|-------|
| 1 | What is potentiometric titration? How the end point is determined graphically? | (3) |
| 2 | What is Galvanic series? How is it different from electrochemical series? | (3) |
| 3 | Which of the following molecules can give IR absorption? Give reason?
(a) O_2 (b) H_2O (c) N_2 (d) HCl | (3) |
| 4 | Which of the following molecules show UV-Visible absorption? Give reason.
(a) Ethane (b) Butadiene (c) Benzene | (3) |

- 5 What are the visualization techniques used in TLC? (3)
- 6 Write the three important applications of nanomaterials. (3)
- 7 Draw the Fischer projection formula and find R-S notation of (3)

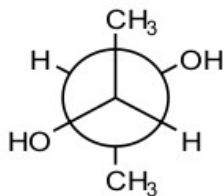

- 8 Write the structure of a) Polypyrrole b) Kevlar. (3)
- 9 What is break point chlorination? (3)
- 10 What is reverse osmosis? (3)

PART B

Answer any one full question from each module, each question carries 14 marks

Module 1

- 11 a) Give the construction of Li-ion cell. Give the reactions that take place at the electrodes during charging and discharging. What happens to anodic material when the cell is 100% charged. (10)
- b) Calculate the standard electrode potential of Cu, if its electrode potential at 25 °C is 0.296 V and the concentration of Cu^{2+} is 0.015 M. (4)

OR

- 12 a) Explain the mechanism of electrochemical corrosion of iron in oxygen rich and oxygen deficient acidic and basic environments. (10)
- b) Given below are reduction potentials of some species (4)

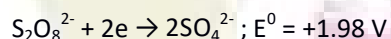
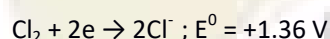
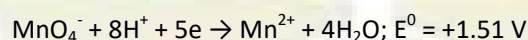

Use the above data to examine whether the acids, dil. HCl and dil. H_2SO_4 , can be used to provide acid medium in redox titrations involving KMnO_4 .

Module 2

- 13 a) What is spin-spin splitting? Draw the NMR spectrum of (i) $\text{CH}_3\text{CH}_2\text{CH}_2\text{Br}$ (ii) $\text{CH}_3\text{CH}(\text{Br})\text{CH}_3$. Explain how NMR spectrum can be used to identify the two isomers. (10)
- b) A dye solution of concentration 0.08M shows absorbance of 0.012 at 600 nm; while a test solution of same dye shows absorbance of 0.084 under same conditions. Find the concentration of the test solution. (4)

OR

- 14 a) Explain the basic principle of UV-Visible spectroscopy. What are the possible electronic transitions? Explain with examples. (10)
- b) Sketch the vibrational modes of CO_2 and H_2O . Which of them are IR active? (4)

Module 3

- 15 a) Explain the principle, instrumentation and procedure involved in gas chromatography. (10)
b) Explain the DTA of $\text{CaC}_2\text{O}_4 \cdot \text{H}_2\text{O}$ with a neat sketch. (4)

OR

- 16 a) Explain the various chemical methods used for the synthesis of nanomaterial (10)
b) How TGA is used to analyse the thermal stability of polymers? (4)

Module 4

- 17 a) What are conformers? Draw the *cis* and *trans* isomers of 1, 3-dimethylcyclohexane. (10)
Which conformer (chair form) is more stable in each case?
b) What is ABS? Give properties and applications. (4)

OR

- 18 a) Explain the various structural isomers with suitable example. (10)
b) What is OLED? Draw a labelled diagram. (4)

Module 5

- 19 a) What are ion exchange resins? Explain ion exchange process for removal of hardness of water? How exhausted resins are regenerated? (10)
b) 50 mL sewage water is diluted to 2000 mL with dilution water; the initial dissolved oxygen was 7.7 ppm. The dissolved oxygen level after 5 days of incubation was 2.4 ppm. Find the BOD of the sewage. (4)

OR

- 20 a) What are the different steps in sewage treatment? Give the flow diagram. Explain the working of trickling filter. (10)
b) Calculate the temporary and permanent hardness of a water sample which contains (4)
 $[\text{Ca}^{2+}] = 160 \text{ mg/L}$, $[\text{Mg}^{2+}] = 192 \text{ mg/L}$ and $[\text{HCO}_3^-] = 122 \text{ mg/L}$.

Syllabus

Module 1

Electrochemistry and Corrosion

Introduction - Differences between electrolytic and electrochemical cells - Daniel cell - redox reactions - cell representation. Different types of electrodes (brief) - Reference electrodes - SHE - Calomel electrode - Glass Electrode - Construction and Working. Single electrode potential - definition - Helmholtz electrical double layer -Determination of E^0 using calomel electrode.Determination of pH using glass electrode.Electrochemical series and its applications. Free energy and EMF - Nernst Equation - Derivation - single electrode and cell (Numericals) -Application - Variation of emf with temperature. Potentiometric titration - Introduction -Redox titration only.Lithiumion cell - construction and working.Conductivity- Measurement of conductivity of a solution (Numericals).

Corrosion-Electrochemicalcorrosion – mechanism. Galvanic series- cathodic protection - electroless plating –Copper and Nickel plating.

Module 2

Spectroscopic Techniques and Applications

Introduction- Types of spectrum - electromagnetic spectrum - molecular energy levels - Beer Lambert's law (Numericals). UV-Visible Spectroscopy – Principle - Types of electronic transitions - Energy level diagram of ethane, butadiene, benzene and hexatriene. Instrumentation of UV-Visible spectrometer and applications. IR-Spectroscopy – Principle - Number of vibrational modes - Vibrational energy states of a diatomic molecule and -Determination of force constant of diatomic molecule (Numericals) –Applications. ^1H NMR spectroscopy – Principle - Relation between field strength and frequency - chemical shift - spin-spin splitting (spectral problems) - coupling constant (definition) - applications of NMR- including MRI (brief).

Module 3

Instrumental Methods and Nanomaterials

Thermal analysis –TGA- Principle, instrumentation (block diagram) and applications – TGA of $\text{CaC}_2\text{O}_4 \cdot \text{H}_2\text{O}$ and polymers. DTA-Principle, instrumentation (block diagram) and applications - DTA of $\text{CaC}_2\text{O}_4 \cdot \text{H}_2\text{O}$. Chromatographic methods - Basic principles and applications of column and TLC- Retention factor. GC and HPLC-Principle, instrumentation (block diagram) - retention time and applications.

Nanomaterials - Definition - Classification - Chemical methods of preparation - Hydrolysis and Reduction - Applications of nanomaterials - Surface characterisation -SEM – Principle and instrumentation (block diagram).

Module 4

Stereochemistry and Polymer Chemistry

Isomerism-Structural, chain, position, functional, tautomerism and matamerism - Definition with examples - Representation of 3D structures-Newman, Sawhorse, Wedge and Fischer projection of substituted methane and ethane. Stereoisomerism - Geometrical isomerism in double bonds and cycloalkanes (cis-trans and E-Z notations). R-S Notation – Rules and examples - Optical isomerism, Chirality, Enantiomers and Diastereoisomers-Definition with examples. Conformational analysis of ethane, butane, cyclohexane, mono and di methyl substituted cyclohexane.

Copolymers - Definition - Types - Random, Alternating, Block and Graft copolymers - ABS - preparation, properties and applications. Kevlar-preparation, properties and applications. Conducting polymers - Doping - Polyaniline and Polypyrrole - preparation properties and applications. OLED - Principle, construction and advantages.

Module 5

Water Chemistry and Sewage Water Treatment

Water characteristics - Hardness - Types of hardness- Temporary and Permanent - Disadvantages of hard water -Units of hardness- ppm and mg/L -Degree of hardness (Numericals) - Estimation of

hardness-EDTA method (Numericals). Water softening methods-Ion exchange process-Principle, procedure and advantages. Reverse osmosis – principle, process and advantages. Municipal water treatment (brief) - Disinfection methods - chlorination, ozone and UV irradiation.

Dissolved oxygen (DO) -Estimation (only brief procedure-Winkler's method), BOD and COD-definition, estimation (only brief procedure) and significance (Numericals). Sewage water treatment - Primary, Secondary and Tertiary - Flow diagram -Trickling filter and UASB process.

Text Books

1. B. L. Tembe, Kamaluddin, M. S. Krishnan, "Engineering Chemistry (NPTEL Web-book)", 2018.
2. P. W. Atkins, "Physical Chemistry", Oxford University Press, 10th edn., 2014.

Reference Books

1. C. N. Banwell, "Fundamentals of Molecular Spectroscopy", McGraw-Hill, 4th edn., 1995.
2. Donald L. Pavia, "Introduction to Spectroscopy", Cengage Learning India Pvt. Ltd., 2015.
3. B. R. Puri, L. R. Sharma, M. S. Pathania, "Principles of Physical Chemistry", Vishal Publishing Co., 47th Edition, 2017.
4. H. H. Willard, L. L. Merritt, "Instrumental Methods of Analysis", CBS Publishers, 7th Edition, 2005.
5. Ernest L. Eliel, Samuel H. Wilen, "Stereo-chemistry of Organic Compounds", WILEY, 2008.
6. Raymond B. Seymour, Charles E. Carraher, "Polymer Chemistry: An Introduction", Marcel Dekker Inc; 4th Revised Edition, 1996.
7. Muhammed Arif, Annette Fernandez, Kavitha P. Nair "Engineering Chemistry", Owl Books, 2019.
8. Ahad J., "Engineering Chemistry", Jai Publication, 2019.
9. Roy K. Varghese, "Engineering Chemistry", Crownplus Publishers, 2019.
10. Soney C. George, Rino Laly Jose, "Text Book of Engineering Chemistry", S. Chand & Company Pvt Ltd, 2019.

Course Contents and Lecture Schedule

No	Topic	No. of Lectures (hrs)
1	Electrochemistry and Corrosion	9
1.1	Introduction - Differences between electrolytic and electrochemical cells- Daniel cell - redox reactions - cell representation. Different types of electrodes (brief) - Reference electrodes- SHE - Calomel electrode - Glass Electrode - Construction and Working.	2
1.2	Single electrode potential – definition - Helmholtz electrical double layer - Determination of E^0 using calomel electrode. Determination of pH using glass electrode. Electrochemical series and its applications. Free energy and EMF - Nernst Equation – Derivation - single electrode and cell (Numericals) -Application -Variation of emf with temperature.	3
1.3	Potentiometric titration - Introduction -Redox titration only. Lithiumion cell - construction and working. Conductivity- Measurement of conductivity of a solution (Numericals).	2
1.4	Corrosion-Electrochemicalcorrosion – mechanism. Galvanic series- cathodic protection - electroless plating –Copper and Nickel plating.	2
2	Spectroscopic Techniques and Applications	9
2.1	Introduction- Types of spectrum - electromagnetic spectrum - molecular energy levels - Beer Lambert’s law (Numericals).	2
2.2	UV-Visible Spectroscopy – Principle - Types of electronic transitions - Energy level diagram of ethane, butadiene, benzene and hexatriene. Instrumentation of UV-Visible spectrometer and applications.	2
2.3	IR-Spectroscopy – Principle - Number of vibrational modes -Vibrational energy states of a diatomic molecule and -Determination of force constant of diatomic molecule (Numericals) –Applications.	2
2.4	^1H NMR spectroscopy – Principle - Relation between field strength and frequency - chemical shift - spin-spin splitting (spectral problems) - coupling constant (definition) - applications of NMR- including MRI (brief).	3
3	Instrumental Methods and Nanomaterials	9
3.1	Thermal analysis –TGA- Principle, instrumentation (block diagram) and applications – TGA of $\text{CaC}_2\text{O}_4 \cdot \text{H}_2\text{O}$ and polymers. DTA-Principle, instrumentation (block diagram) and applications - DTA of $\text{CaC}_2\text{O}_4 \cdot \text{H}_2\text{O}$.	2

3.2	Chromatographic methods - Basic principles and applications of column and TLC-Retention factor.	2
3.3	GC and HPLC-Principle, instrumentation (block diagram) - retention time and applications.	2
3.4	Nanomaterials - Definition - Classification - Chemical methods of preparation - Hydrolysis and Reduction - Applications of nanomaterials - Surface characterisation -SEM – Principle and instrumentation (block diagram).	3
4	Stereochemistry and Polymer Chemistry	9
4.1	Isomerism-Structural, chain, position, functional, tautomerism and matamerism - Definition with examples - Representation of 3D structures-Newman, Sawhorse, Wedge and Fischer projection of substituted methane and ethane. Stereoisomerism - Geometrical isomerism in double bonds and cycloalkanes (cis-trans and E-Z notations).	2
4.2	R-S Notation – Rules and examples - Optical isomerism, Chirality, Enantiomers and Diastereoisomers-Definition with examples.	1
4.3	Conformational analysis of ethane, butane, cyclohexane, mono and di methyl substituted cyclohexane.	2
4.4	Copolymers - Definition - Types - Random, Alternating, Block and Graft copolymers - ABS - preparation, properties and applications. Kevlar-preparation, properties and applications. Conducting polymers - Doping -Polyaniline and Polypyrrole - preparation properties and applications. OLED - Principle, construction and advantages.	4
5	Water Chemistry and Sewage Water Treatment	9
5.1	Water characteristics - Hardness - Types of hardness- Temporary and Permanent - Disadvantages of hard water -Units of hardness- ppm and mg/L -Degree of hardness (Numericals) - Estimation of hardness-EDTA method (Numericals). Water softening methods-Ion exchange process-Principle, procedure and advantages. Reverse osmosis – principle, process and advantages.	3
5.2	Municipal water treatment (brief) - Disinfection methods - chlorination, ozone and UV irradiation.	2
5.3	Dissolved oxygen (DO) -Estimation (only brief procedure-Winkler's method), BOD and COD-definition, estimation (only brief procedure) and significance (Numericals).	2
5.4	Sewage water treatment - Primary, Secondary and Tertiary - Flow diagram - Trickling filter and UASB process.	2

EST 100	ENGINEERING MECHANICS	CATEGORY	L	T	P	CREDIT	Year of Introduction
		ESC	2	1	0	3	2019

Preamble: Goal of this course is to expose the students to the fundamental concepts of mechanics and enhance their problem-solving skills. It introduces students to the influence of applied force system and the geometrical properties of the rigid bodies while stationary or in motion. After this course students will be able to recognize similar problems in real-world situations and respond accordingly.

Prerequisite: Nil

Course Outcomes: After completion of the course the student will be able to:

CO 1	Recall principles and theorems related to rigid body mechanics
CO 2	Identify and describe the components of system of forces acting on the rigid body
CO 3	Apply the conditions of equilibrium to various practical problems involving different force system.
CO 4	Choose appropriate theorems, principles or formulae to solve problems of mechanics.
CO 5	Solve problems involving rigid bodies, applying the properties of distributed areas and masses

Mapping of course outcomes with program outcomes (Minimum requirement)

	PO 1	PO 2	PO 3	PO 4	PO 5	PO 6	PO 7	PO 8	PO 9	PO 10	PO 11	PO 12
CO 1	2	2	-	-	-	-	-	-	-	-	-	-
CO 2	3	3	-	-	-	-	-	-	-	-	-	-
CO 3	3	3	-	-	-	-	-	-	-	-	-	-
CO 4	3	3	-	-	-	-	-	-	-	-	-	-
CO 5	3	3	-	-	-	-	-	-	-	-	-	-

Assessment Pattern

Bloom's Category	Continuous Assessment Tests		End Semester Examination (Marks)
	Test 1 (Marks)	Test 2 (Marks)	
Remember	10	10	15
Understand	10	10	15
Apply	30	30	70
Analyse			
Evaluate			
Create			

Mark distribution

Total Marks	CIE marks	ESE marks	ESE Duration
150	50	100	3 hours

Continuous Internal Evaluation Pattern:

Attendance	: 10 marks
Continuous Assessment Test (2 numbers)	: 25 marks
Assignment/Quiz/Course project	: 15 marks

End Semester Examination Pattern: There will be two parts; Part A and Part B. Part A contain 10 questions with 2 questions from each module, having 3 marks for each question. Students should answer all questions. Part B contains 2 questions from each module of which student should answer any one. Each question can have maximum 2 sub-divisions and carry 14 marks.

Course Level Assessment Questions:

Part A

Course Outcome 1 (CO1): (One question from each module to meet the course objective 1: *To recall principles and theorems related to rigid body mechanics*)

1. Explain D'Alembert's principle
2. Distinguish static and dynamic friction
3. State and explain perpendicular axis theorem

Course Outcome 2 (CO2) (One question from each module to meet the course objective 2: *To identify and describe the components of system of forces acting on the rigid body*)

1. A simply supported beam AB of span 5 m is carrying point loads 5 kN, 3 kN and 2 kN at 1m, 3m and 4m respectively from support A. Calculate the support reaction at B.
2. A gymnast holding onto a bar, is suspended motionless in mid-air. The bar is supported by two ropes that attach to the ceiling. Diagram the forces acting on the combination of gymnast and bar
3. While you are riding your bike, you turn a corner following a circular arc. Illustrate the forces that act on your bike to keep you along the circular path ?

Part B

All the questions under this section shall assess the learning levels corresponding to the course outcomes listed below.

CO 3	To apply the conditions of equilibrium to various practical problems involving different force system.
CO 4	To choose appropriate theorems, principles or formulae to solve problems of mechanics.
CO 5	To solve problems involving rigid bodies, applying the properties of distributed areas and masses

1. Two rollers each of weight 100 N are supported by an inclined plane and a vertical wall. Find the reaction at the points of contact A, B, C. Assume all the surfaces to be smooth.

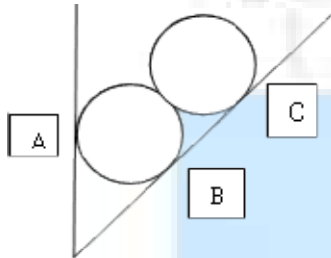

Course outcome identifier	Description of course outcome	Learning level assessed	Marks allocated
CO 3	To apply the conditions of equilibrium to various practical problems involving different force system.	Applying – (Sketch the free body diagram that represent equilibrium state of the body)	4
CO 4	To choose appropriate theorems, principles or formulae to solve problems of mechanics.	Applying (Choose the equations and formulae required for calculation)	4
CO 5	To solve problems involving rigid bodies, applying the properties of distributed areas and masses	Applying (Solve the problem based on the descriptions given in CO3 and CO4)	6
Total			14

2. A cylindrical disc, 50 cm diameter and cm thickness, is in contact with a horizontal conveyor belts running at uniform speeds of 5 m/s. Assuming there is no slip at points of contact determine (i) angular velocity of disc (ii) Angular acceleration of disc if velocity of conveyor changes to 8 m/s. Also compute the moment acting about the axis of the disc in both cases.

Course outcome identifier	Description of course outcome	Learning level assessed	Marks allocated
CO 3	To apply the conditions of equilibrium to various practical problems involving different force system.	Applying – (Sketch the free body diagram that represent state of the body)	4
CO 4	To choose appropriate theorems, principles or formulae to solve problems of mechanics.	Applying (Choose the equations and formulae required for calculation)	4
CO 5	To solve problems involving rigid bodies, applying the properties of distributed areas and masses	Applying (Solve the problem based on the descriptions given in CO3 and CO4)	6
Total			14

3. Determine the centroid of the given section

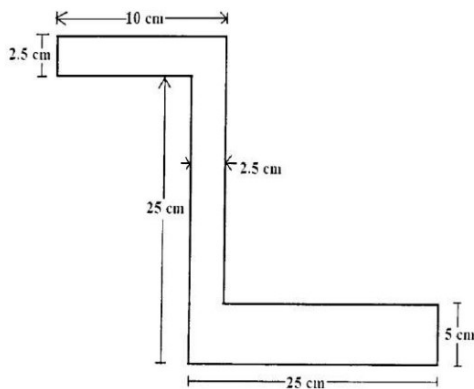

Course outcome identifier	Description of course outcome	Learning level assessed	Marks allocated
CO 3	To apply the conditions of equilibrium to various practical problems involving different force system.	Applying – (Illustrate the computation of centroid for the given geometrical shape)	4
CO 4	To choose appropriate theorems, principles or formulae to solve problems of mechanics.	Applying (Choose the equations and formulae required for calculation)	4
CO 5	To solve problems involving rigid bodies, applying the properties of distributed	Applying (Solve the problem based on the descriptions	6

	areas and masses	given in CO3 and CO4)	
Total			14

4. A rectangular hole is made in a triangular section as shown. Find moment of inertia about the section x-x passing through the CG of the section and parallel to BC.

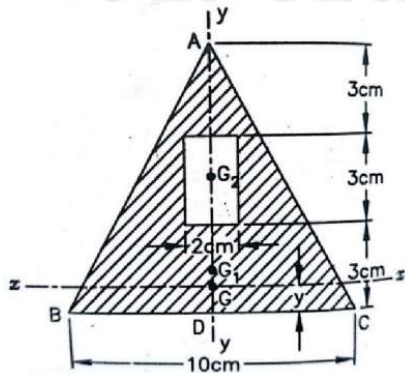

Course outcome identifier	Description of course outcome	Learning level assessed	Marks allocated
CO 3	To apply the conditions of equilibrium to various practical problems involving different force system.	Applying – (Illustrate the computation of moment of inertia for the given geometrical shape)	4
CO 4	To choose appropriate theorems, principles or formulae to solve problems of mechanics.	Applying (Choose the equations and formulae required for calculation)	4
CO 5	To solve problems involving rigid bodies, applying the properties of distributed areas and masses	Applying (Solve the problem based on the descriptions given in CO3 and CO4)	6
Total			14

Model Question Paper

QP CODE:

Reg No.: _____

Name: _____

APJ ABDUL KALAM TECHNOLOGICAL UNIVERSITY FIRST SEMESTER B.TECH DEGREE EXAMINATION,
MONTH & YEAR

Course Code: EST 100

ENGINEERING MECHANICS

Max. Marks: 100

Duration: 3 hours

Part A

(Answer all questions; each question carries 3 marks)

1. Explain D'Alembert's principle
2. Distinguish static and dynamic friction.
3. State and explain perpendicular axis theorem.
4. A simply supported beam AB of span 5 m is carrying point loads 5 kN, 3 kN and 2 kN at 1m, 3m and 4m respectively from support A. Calculate the support reaction at B.
5. A gymnast holding onto a bar, is suspended motionless in mid-air. The bar is supported by two ropes that attach to the ceiling. Diagram the forces acting on the combination of gymnast and bar
6. While you are riding your bike, you turn a corner following a circular arc. Illustrate the forces that act on your bike to keep you along the circular path ?
7. Compare damped and undamped free vibrations.
8. State the equation of motion of a rotating rigid body, rotating about its fixed axis.
9. Illustrate the significance of instantaneous centre in the analysis of rigid body undergoing rotational motion.
10. Highlight the principles of mechanics applied in the evaluation of elastic collision of rigid bodies.

PART B

(Answer **one full** question from each module, each question carries **14** marks)

Module -I

11. Two identical rollers each of weight 100 N are supported by an inclined plane, making an angle of 30° with the vertical, and a vertical wall. Find the reaction at the points of contact A, B, C. Assume all the surfaces to be smooth. (14 marks)

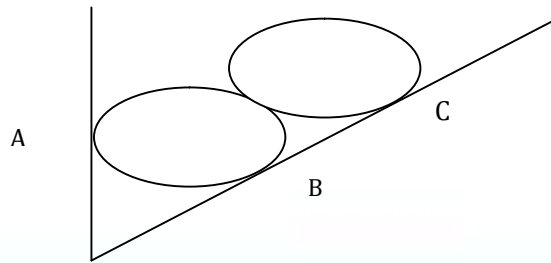

12. A string tied to a wall is made to pass over a pulley placed 2m away from it. A weight P is attached to the string such that the string stretches by 2m from the support on the wall to the location of attachment of weight. Determine the force P required to maintain 200 kg body in position for $\theta = 30^\circ$, The diameter of pulley B is negligible. (14 marks)

Module – 2

13. Two blocks A & B are resting against a wall and the floor as shown in figure below. Find the value of horizontal force P applied to the lower block that will hold the system in equilibrium. Coefficient of friction are : 0.25 at the floor, 0.3 at the wall and 0.2 between the blocks. (14 marks)

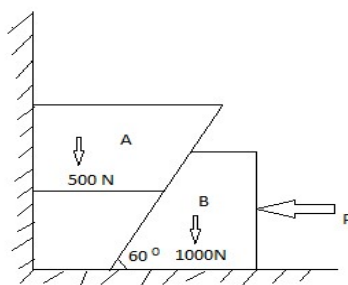

14. A beam is hinged at A and roller supported at B. It is acted upon by loads as shown below. Find the reactions at A & B. (14 marks)

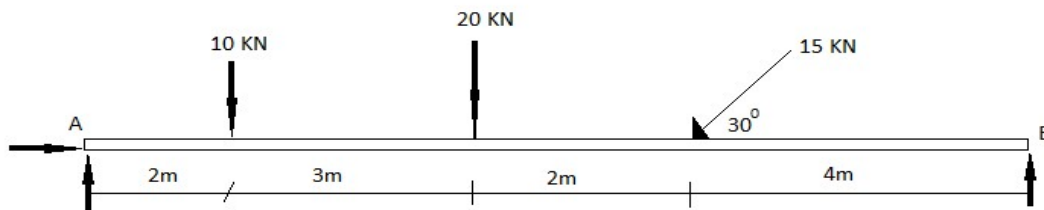

Module – 3

15. A rectangular hole is made in a triangular section as shown. Find moment of inertia about the section x-x passing through the CG of the section and parallel to BC. (14 marks)

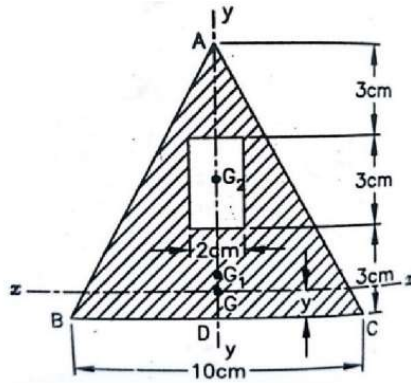

16. Support A has ball and socket connection. Roller support at B prevents motion in the $-z$ direction. Corner C is tied to D by a rope. The triangle is weightless. Determine the unknown force components acting at A, B, and C. (14 marks)

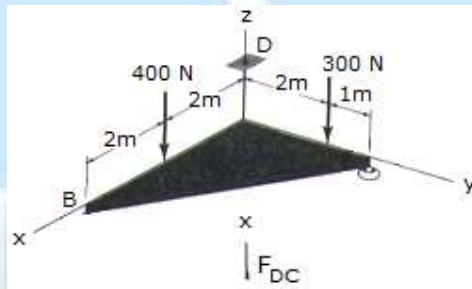

Module - 4

17. A cricket ball is thrown by a fielder from a height of 2m at an angle of 30° to the horizontal with an initial velocity of 20 m/s, hits the wickets at a height of 0.5 m from the ground. How far was the fielder from the wicket? (14 marks)

18. An engine of weight 500 kN pull a train weighing 1500 kN up an incline of 1 in 100. The train starts from rest and moves with constant acceleration against a resistance of 5 N/kN. It attains a maximum speed of 36 kmph in 1 km distance. Determine the tension in the coupling between train and engine and the traction force developed by the engine. (14marks)

Module - 5

19. A cylindrical disc, 50 cm diameter and 10 cm thickness having mass of 10 kg, is in contact with a horizontal conveyor belt running at uniform speeds of 5 m/s. Assuming there is no slip at points of contact determine (i) angular velocity of disc (ii) Angular acceleration of disc if velocity of conveyor changes to 8 m/s in 10 seconds. Also compute the moment acting about the axis of the disc in both cases. (14 marks)

20. A wheel rotating about fixed axis at 20 rpm is uniformly accelerated for 70 seconds during which time it makes 50 revolutions. Find the (i) angular velocity at the end of this interval and (ii) time required for the velocity to reach 100 revolutions per minute. (14 marks)

SYLLABUS

Module 1

Introduction to Engineering Mechanics-statics-basic principles of statics-Parallelogram law, equilibrium law, principles of superposition and transmissibility, law of action and reaction(review) free body diagrams.

Concurrent coplanar forces-composition and resolution of forces-resultant and equilibrium equations – methods of projections – methods of moments – Varignon's Theorem of moments.

Module 2

Friction – sliding friction - Coulomb's laws of friction – analysis of single bodies –wedges, ladder-analysis of connected bodies .

Parallel coplanar forces – couple - resultant of parallel forces – centre of parallel forces – equilibrium of parallel forces – Simple beam subject to concentrated vertical loads. General coplanar force system - resultant and equilibrium equations.

Module 3

Centroid of composite areas- – moment of inertia-parallel axis and perpendicular axis theorems. Polar moment of inertia, radius of gyration, mass moment of inertia-ring, cylinder and disc.

Theorem of Pappus Guldinus(demonstration only)

Forces in space - vectorial representation of forces, moments and couples –resultant and equilibrium equations – concurrent forces in space (simple problems only)

Module 4

Dynamics – rectilinear translation - equations of kinematics(review)

kinetics – equation of motion – D'Alembert's principle. – motion on horizontal and inclined surfaces, motion of connected bodies. Impulse momentum equation and work energy equation (concepts only).

Curvilinear translation - equations of kinematics –projectile motion(review), kinetics – equation of motion. Moment of momentum and work energy equation (concepts only).

Module 5

Rotation – kinematics of rotation- equation of motion for a rigid body rotating about a fixed axis – rotation under a constant moment.

Plane motion of rigid body – instantaneous centre of rotation (concept only).

Simple harmonic motion – free vibration –degree of freedom- undamped free vibration of spring mass system-effect of damping(concept only)

Text Books

1. Timoshenko and Young, Engineering Mechanics, McGraw Hill Publishers
2. Shames, I. H., Engineering Mechanics - Statics and Dynamics, Prentice Hall of India.
3. R. C. Hibbeler and Ashok Gupta, Engineering Mechanics, Vol. I statics, Vol II Dynamics, Pearson Education.

References

1. Merriam J. L and Kraige L. G., Engineering Mechanics - Vols. 1 and 2, John Wiley.
2. Tayal A K, Engineering Mechanics – Statics and Dynamics, Umesh Publications
3. Bhavikkatti, S.S., Engineering Mechanics, New Age International Publishers
4. F.P.Beer and E.R.Johnston (2011), Vector Mechanics for Engineers, Vol.I-Statics, Vol.II-Dynamics, 9th Ed, Tata McGraw Hill
5. Rajasekaran S and Sankarasubramanian G, Engineering Mechanics - Statics and Dynamics, Vikas Publishing House Pvt Ltd.

Course Contents and Lecture Schedule:

Module	Topic	Course outcomes addressed	No. of Hours
1	Module 1		Total: 7
1.1	Introduction to engineering mechanics – introduction on statics and dynamics - Basic principles of statics – Parellogram law, equilibrium law – Superposition and transmissibility, law of action and reaction (review the topics)	CO1 and CO2	1
1.2	Free body diagrams. Degree of freedom-types of supports and nature of reactions - exercises for free body diagram preparation – composition and resolution of forces, resultant and equilibrium equations (review the topics) - numerical exercises for illustration.	CO1 and CO2	1
1.3	Concurrent coplanar forces - analysis of concurrent forces -methods of projections – illustrative numerical exercise – teacher assisted problem solving.	CO1 and CO2	1
1.4	Analysis of concurrent forces -methods of moment-Varignon’s Theorem of Moments - illustrative numerical exercise– teacher assisted problem solving.	CO1 and CO2	1
1.5	Analysis of concurrent force systems – extended problem solving - Session I.	CO3,CO4 and CO5	1
1.6	Analysis of concurrent force systems – extended problem solving - Session II – learning review quiz.	CO3,CO4 and CO5	1
1.7	Analysis of concurrent force systems – extended problem solving - Session III.	CO3,CO4 and CO5	1
2	Module 2		Total: 7
2.1	Friction – sliding friction - Coulomb’s laws of friction – analysis of single bodies –illustrative examples on wedges and ladder-teacher	CO1 and CO2	1

	assisted problem solving tutorials using problems from wedges and ladder.		
2.2	Problems on friction - analysis of connected bodies. illustrative numerical exercise– teacher assisted problem solving.	CO3, CO4 and CO5	1
2.3	Problems on friction-extended problem solving	CO3,CO4 and CO5	1
2.4	Parallel coplanar forces – couple - resultant of parallel forces – centre of parallel forces – equilibrium of parallel forces – Simple beam subject to concentrated vertical loads.	CO1 and CO2	1
2.5	General coplanar force system - resultant and equilibrium equations - illustrative examples- teacher assisted problem solving.	CO1 and CO2	1
2.6	General coplanar force system-resultant and equilibrium equations - illustrative examples	CO3, CO4 and CO5	1
2.7	General coplanar force system - Extended problem solving - Quiz to evaluate learning level.	CO3, CO4 and CO5	1
3	Module 3		Total: 7
3.1	Centroid of simple and regular geometrical shapes – centroid of figures in combination - composite areas- examples for illustration – problems for practice to be done by self.	CO1 and CO2	1
3.2	Moment of inertia- parallel axis theorem –examples for illustration - problems for practice to be done by self.	CO1 and CO2	1
3.3	Moment of inertia - perpendicular axis theorem - example for illustration to be given as hand out and discussion on the solved example.	CO1 and CO2	1
3.4	Solutions to practice problems – problems related to centroid and moment of inertia - problems for practice to be done by self.	CO3, CO4 and CO5	1
3.5	Polar moment of inertia, Radius of gyration. Mass moment of inertia of ring, cylinder and uniform disc. Theorem of Pappus Guldinus - Demonstration	CO1 and CO2	1
3.6	Introduction to forces in space – vectorial representation of forces, moments and couples – simple problems to illustrate vector representations of forces, moments and couples to be done in class.	CO1,and CO2	1
3.7	Solution to practice problems - resultant and equilibrium equations for concurrent forces in space – concurrent forces in space - 2 simple problems to illustrate the application of resultant and equilibrium equations for concurrent forces in space.	CO3,CO4 and CO5	1
4	Module 4		Total: 7

4.1	Introduction to dynamics – review of rectilinear translation - equations of kinematics – problems to review the concepts – additional problems involving extended application as exercises .	CO1 and CO2	1
4.2	Solutions to exercises with necessary explanation given as hand out – introduction to kinetics – equation of motion – D’Alembert’s principle – illustration of the concepts using one numerical exercise from motion on horizontal and inclined surfaces.	CO1 and CO2	1
4.3	Motion of connected bodies - example for illustration to be given as hand out and discussion on the solved example – problems for practice to be done by self.	CO3, CO4 and CO5	1
4.4	Motion of connected bodies-extended problem solving.	CO3, CO4 & CO5	1
4.5	Curvilinear translation - Review of kinematics –projectile motion – simple problems to review the concepts – introduction to kinetics – equation of motion – illustration of the concepts using numerical exercises.	CO3, CO4 & CO5	1
4.6	Extended problem solving – rectilinear and curvilinear translation.	CO3, CO4 & CO5	1
4.7	Concepts on Impulse momentum equation and work energy equation (rectilinear translation – discussions to bring out difference between elastic and inelastic collisions). Concepts on Moment of momentum and work energy equation (curvilinear translation).	CO1 and CO2	1
5	Module 5		Total: 7
5.1	Rotation – kinematics of rotation- equation of motion for a rigid body rotating about a fixed axis – simple problems for illustration.	CO1 and CO2	1
5.2	Rotation under a constant moment – teacher assisted problem solving.	CO3,CO4 and CO5	1
5.3	Rotation under a constant moment - extended problem solving.	CO3, CO4 and CO5	1
5.4	Plane motion of rigid body- instantaneous centre of rotation (concept only).	CO1 and CO2	1
5.5	Introduction to harmonic oscillation –free vibrations - simple harmonic motion – differential equation and solution. Degree of freedom – examples of single degree of freedom (SDOF) systems – Idealisation of mechanical systems as spring-mass systems (concept only).	CO1 and CO2	1

5.6	SDOF spring mass system –equation of motion – undamped free vibration response - concept of natural frequency. Free vibration response due to initial conditions. Simple problems on determination of natural frequency and free vibration response to test the understanding level.	CO1 and CO2	1
5.7	Free vibration analysis of SDOF spring-mass systems – Problem solving Effect of damping on free vibration response (concept only).	CO1and CO2	1

AL-FALAH KARAM
TECHNOLOGICAL
UNIVERSITY



EST 130	BASICS OF ELECTRICAL AND ELECTRONICS ENGINEERING	CATEGORY	L	T	P	CREDIT	YEAR OF INTRODUCTION
		ESC	4	0	0	4	2019

Preamble:

This course aims to (1) equip the students with an understanding of the fundamental principles of electrical engineering (2) provide an overview of evolution of electronics, and introduce the working principle and examples of fundamental electronic devices and circuits (3) provide an overview of evolution of communication systems, and introduce the basic concepts in radio communication.

Prerequisite: Physics and Mathematics (Pre-university level)

Course Outcomes: After the completion of the course the student will be able to

CO 1	Apply fundamental concepts and circuit laws to solve simple DC electric circuits
CO 2	Develop and solve models of magnetic circuits
CO 3	Apply the fundamental laws of electrical engineering to solve simple ac circuits in steady state
CO 4	Describe working of a voltage amplifier
CO 5	Outline the principle of an electronic instrumentation system
CO 6	Explain the principle of radio and cellular communication

Mapping of course outcomes with program outcomes

	PO 1	PO 2	PO 3	PO 4	PO 5	PO 6	PO 7	PO 8	PO 9	PO 10	PO 11	PO 12
CO 1	3	1	-	-	-	-	-	-	-	-	-	2
CO 2	3	1	-	-	-	-	-	-	-	-	-	2
CO 3	3	1	-	-	-	-	-	-	-	-	-	2
CO 4	2	-	-	-	-	-	-	-	-	-	-	-
CO 5	2	-	-	-	-	-	-	-	-	-	-	2
CO 6	2	-	-	-	-	-	-	-	-	-	-	2

Assessment Pattern

Bloom's Category	Basic Electrical Engineering			Basic Electronics Engineering		
	Continuous Assessment Tests		End Semester Examination (Marks)	Continuous Assessment Tests		End Semester Examination (Marks)
	Test 1 (Marks)	Test 2 (Marks)		Test 1 (Marks)	Test 2 (Marks)	
Remember	0	0	10	10	10	20
Understand	12.5	12.5	20	15	15	30
Apply	12.5	12.5	20			
Analyse						
Evaluate						
Create						

Mark distribution

Total Marks	CIE marks	ESE marks	ESE Duration
150	50	100	3 hours

Continuous Internal Evaluation Pattern:

Attendance	: 10 marks
Continuous Assessment Test (2 numbers)	: 25 marks
Assignment/Quiz/Course project	: 15 marks

End Semester Examination Pattern: There will be two parts; Part I – Basic Electrical Engineering and Part II – Basic Electronics Engineering. Part I and PART II carries 50 marks each. For the end semester examination, part I contain 2 parts - Part A and Part B. Part A contain 5 questions carrying 4 marks each (not exceeding 2 questions from each module). Part B contains 2 questions from each module out of which one to be answered. Each question carries 10 mark and can have maximum 2 sub-divisions. The pattern for end semester examination for part II is same as that of part I. **However, student should answer both part I and part 2 in separate answer booklets.**

Course Level Assessment Questions

Course Outcome 1 (CO1):

1. Solve problems based on current division rule.
2. Solve problems with Mesh/node analysis.
3. Solve problems on Wye-Delta Transformation.

Course Outcome 2 (CO2):

1. Problems on series magnetic circuits
2. Problems on parallel magnetic circuits
3. Problems on composite magnetic circuits

4. Course Outcome 3 (CO3):

1. problems on self inductance, mutual inductance and coefficient of coupling
2. problems on rms and average values of periodic waveforms
3. problems on series ac circuits
4. Compare star and Delta connected 3 phase AC systems.

Course Outcome 4 (CO4): Describe working of a voltage amplifier

1. What is the need of voltage divider biasing in an RC coupled amplifier?

2. Define operating point in the context of a BJT amplifier.
3. Why is it required to have a voltage amplifier in a public address system?

Course Outcome 5 (CO5): Outline the principle of an electronic instrumentation system

1. Draw the block diagram of an electronic instrumentation system.
2. What is a transducer?
3. Explain the working principle of operation of digital multimeter.

Course Outcome 6 (CO6): Explain the principle of radio and cellular communication

1. What is the working principle of an antenna when used in a radio transmitter?
2. What is the need of two separate sections RF section and IF section in a super heterodyne receiver?
3. What is meant by a cell in a cellular communication?

Model Question Paper

QP CODE:

Pages: 3

Reg No.: _____

Name: _____

**APJ ABDUL KALAM TECHNOLOGICAL UNIVERSITY FIRST SEMESTER B.TECH DEGREE EXAMINATION,
MONTH & YEAR**

Course Code: EST 130

Course Name: BASICS OF ELECTRICAL AND ELECTRONICS ENGINEERING

Max. Marks: 100

Duration: 3 hours

Answer both part I and part 2 in separate answer booklets

PART I

BASIC ELECTRICAL ENGINEERING

PART A

Answer all questions; each question carries 4 marks.

1. Calculate the current through the 4Ω resistor in the circuit shown, applying current division rule:

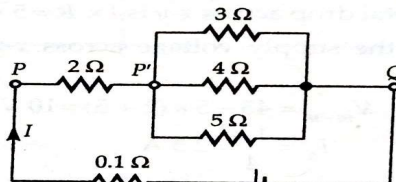

2. Calculate the RMS and average values of a purely sinusoidal current having peak value 15A.
3. An alternating voltage of $(80+j60)V$ is applied to an RX circuit and the current flowing through the circuit is $(-4+j10)A$. Calculate the impedance of the circuit in rectangular and polar forms. Also determine if X is inductive or capacitive.
4. Derive the relation between line and phase values of voltage in a three phase star connected system.
5. Compare electric and magnetic circuits. (5x4=20)

PART B

Answer one question from each module; each question carries 10 marks.

Module 1

6. . Calculate the node voltages in the circuit shown, applying node analysis:

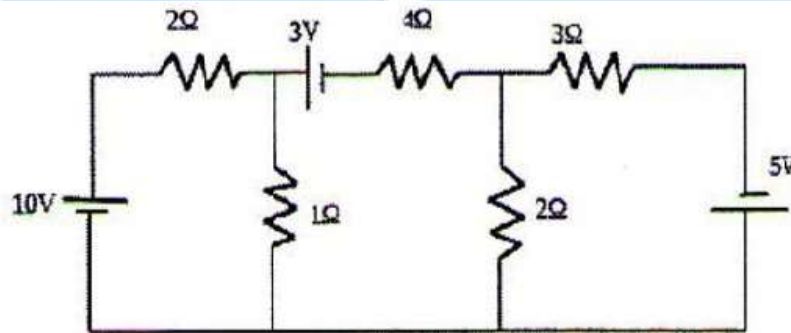

7. (a) State and explain Kirchoff's laws. (4 marks)

- (b) Calculate the current through the galvanometer (G) in the circuit shown:

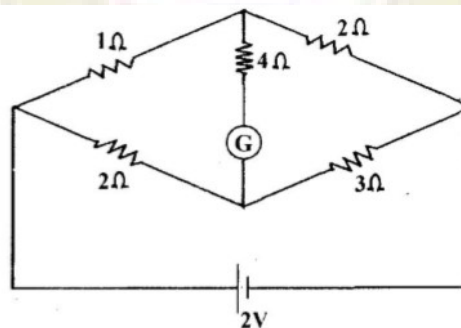

(6 marks)

Module 2

8. (a) State and explain Faraday's laws of electromagnetic induction with examples. (4 marks)
- (b) Differentiate between statically and dynamically induced emf. A conductor of length 0.5m moves in a uniform magnetic field of flux density 1.1T at a velocity of 30m/s. Calculate the emf induced in the conductor if the direction of motion of the conductor is inclined at 60° to the direction of field. (6 marks)
9. (a) Derive the amplitude factor and form factor of a purely sinusoidal waveform. (5 marks)
- (b) A current wave is made up of two components—a 5A dc component and a 50Hz ac component, which is a sinusoidal wave with a peak value of 5A. Sketch the resultant waveform and determine its RMS and average values. (5 marks)

Module 3

10. Draw the power triangle and define active, reactive and apparent powers in ac circuits. Two coils A and B are connected in series across a 240V, 50Hz supply. The resistance of A is 5Ω and the inductance of B is 0.015H. If the input from the supply is 3kW and 2kVAR, find the inductance of A and the resistance of B. Also calculate the voltage across each coil.
11. A balanced three phase load consists of three coils each having resistance of 4Ω and inductance 0.02H. It is connected to a 415V, 50Hz, 3-phase ac supply. Determine the phase voltage, phase current, power factor and active power when the loads are connected in (i) star (ii) delta.

(3x10=30)

PART II

BASIC ELECTRONICS ENGINEERING

PART A

Answer all questions; each question carries 4 marks.

1. Give the specifications of a resistor. The colour bands marked on a resistor are Blue, Grey, Yellow and Gold. What are the minimum and maximum resistance values expected from that resistance?
2. What is meant by avalanche breakdown?
3. Explain the working of a full-wave bridge rectifier.
4. Discuss the role of coupling and bypass capacitors in a single stage RC coupled amplifier.
5. Differentiate AM and FM communication systems.

(5x4=20)

PART B

Answer one question from each module; each question carries 10 marks.

Module 4

6. a) Explain with diagram the principle of operation of an NPN transistor. (5)
b) Sketch and explain the typical input-output characteristics of a BJT when connected in common emitter configuration. (5)

OR

7. a) Explain the formation of a potential barrier in a P-N junction diode. (5)
b) What do you understand by Avalanche breakdown? Draw and explain the V-I characteristics of a P-N junction and Zener diode. (5)

Module 5

8. a) With a neat circuit diagram, explain the working of an RC coupled amplifier. (6)
b) Draw the frequency response characteristics of an RC coupled amplifier and state the reasons for the reduction of gain at lower and higher frequencies. (4)

OR

9. a) With the help of block diagram, explain how an electronic instrumentation system. (6)
b) Explain the principle of an antenna. (4)

Module 6

10. a) With the help of a block diagram, explain the working of Super hetrodyne receiver. (6)
b) Explain the importance of antenna in a communication system. (4)

OR

11. a) With neat sketches explain a cellular communication system. (5)
b) Explain GSM communication with the help of a block diagram. (5)

(3x10=30)

SYLLABUS

MODULE 1: Elementary Concepts of Electric Circuits

Elementary concepts of DC electric circuits: Basic Terminology including voltage, current, power, resistance, emf; Resistances in series and parallel; Current and Voltage Division Rules; Capacitors & Inductors: V-I relations and energy stored. Ohms Law and Kirchhoff's laws-Problems; Star-delta conversion (resistive networks only-derivation not required)-problems.

Analysis of DC electric circuits: Mesh current method - Matrix representation - Solution of network equations. Node voltage methods-matrix representation-solution of network equations by matrix methods. Numerical problems.

MODULE 2: Elementary Concepts of Magnetic circuits, Electromagnetic Induction and AC fundamentals

Magnetic Circuits: Basic Terminology: MMF, field strength, flux density, reluctance - comparison between electric and magnetic circuits- Series and parallel magnetic circuits with composite materials, numerical problems.

Electromagnetic Induction: Faraday's laws, problems, Lenz's law- statically induced and dynamically induced emfs - Self-inductance and mutual inductance, coefficient of coupling

Alternating Current fundamentals: Generation of alternating voltages-Representation of sinusoidal waveforms: frequency, period, Average, RMS values and form factor of waveforms-Numerical Problems.

MODULE 3: AC Circuits

AC Circuits: Phasor representation of sinusoidal quantities. Trigonometric, Rectangular, Polar and complex forms. Analysis of simple AC circuits: Purely resistive, inductive & capacitive circuits; Inductive and capacitive reactance, concept of impedance. Average Power Power factor. Analysis of RL, RC and RLC series circuits-active, reactive and apparent power. Simple numerical problems.

Three phase AC systems: Generation of three phase voltages; advantages of three phase systems, star and delta connections (balanced only), relation between line and phase voltages, line and phase currents- Numerical problems

MODULE 4

Introduction to Semiconductor devices: Evolution of electronics – Vacuum tubes to nano electronics. Resistors, Capacitors and Inductors (constructional features not required): types, specifications. Standard values, color coding. PN Junction diode: Principle of operation, V-I characteristics, principle of avalanche breakdown. Bipolar Junction Transistors: PNP and NPN structures, Principle of operation, relation between current gains in CE, CB and CC, input and output characteristics of common emitter configuration.

MODULE 5

Basic electronic circuits and instrumentation: Rectifiers and power supplies: Block diagram description of a dc power supply, Working of a full wave bridge rectifier, capacitor filter (no analysis), working of simple zener voltage regulator. Amplifiers: Block diagram of Public Address system, Circuit diagram and working of common emitter (RC coupled) amplifier with its frequency response, Concept of voltage divider biasing. Electronic Instrumentation: Block diagram of an electronic instrumentation system.

MODULE 6

Introduction to Communication Systems: Evolution of communication systems – Telegraphy to 5G. Radio communication: principle of AM & FM, frequency bands used for various communication systems, block diagram of super heterodyne receiver, Principle of antenna – radiation from accelerated charge. Mobile communication: basic principles of cellular communications, principle and block diagram of GSM.

Text Books

1. D P Kothari and I J Nagrath, "Basic Electrical Engineering", Tata McGraw Hill, 2010.
2. D C Kulshreshtha, "Basic Electrical Engineering", Tata McGraw Hill, 2010.
3. ChinmoySaha, Arindham Halder and Debarati Ganguly, Basic Electronics - Principles and Applications, Cambridge University Press, 2018.
4. M.S.Sukhija and T.K.Nagsarkar, Basic Electrical and Electronics Engineering, Oxford University Press, 2012.
5. Wayne Tomasi and Neil Storey, A Textbook On Basic Communication and Information Engineering, Pearson, 2010.

Reference Books

1. Del Toro V, "Electrical Engineering Fundamentals", Pearson Education.
2. T. K. Nagsarkar, M. S. Sukhija, "Basic Electrical Engineering", Oxford Higher Education.
3. Hayt W H, Kemmerly J E, and Durbin S M, "Engineering Circuit Analysis", Tata McGraw-Hill
4. Hughes, "Electrical and Electronic Technology", Pearson Education.
5. V. N. Mittle and Arvind Mittal, "Basic Electrical Engineering," Second Edition, McGraw Hill.
6. Parker and Smith, "Problems in Electrical Engineering", CBS Publishers and Distributors.
7. S. B. Lal Seksena and Kaustuv Dasgupta, "Fundamentals of Electrical Engineering", Cambridge University Press.
8. Anant Agarwal, Jeffrey Lang, Foundations of Analog and Digital Electronic Circuits, Morgan Kaufmann Publishers, 2005.
9. Bernard Grob, Basic Electronics, McGraw Hill.
10. A. Bruce Carlson, Paul B. Crilly, Communication Systems: An Introduction to Signals and Noise in Electrical Communication, Tata McGraw Hill, 5th Edition.

COURSE CONTENTS AND LECTURE SCHEDULE

No	Topic	No. of Lectures
1	<i>Elementary Concepts of Electric Circuits</i>	
1.1	<p>Elementary concepts of DC electric circuits:</p> <p>Basic Terminology including voltage, current, power, resistance, emf; Resistances in series and parallel; Current and Voltage Division Rules; Capacitors & Inductors: V-I relations and energy stored.</p> <p>Ohms Law and Kirchhoff's laws-Problems;</p> <p>Star-delta conversion (resistive networks only-derivation not required)-problems.</p>	1 2 1
1.2	<p>Analysis of DC electric circuits: Mesh current method - Matrix representation - Solution of network equations.</p> <p>Node voltage methods-matrix representation-solution of network equations by matrix methods.</p> <p>Numerical problems.</p>	1 1 2
2	Elementary Concepts of Magnetic circuits, Electromagnetic Induction and AC fundamentals	
2.1	<p>Magnetic Circuits: Basic Terminology: MMF, field strength, flux density, reluctance - comparison between electric and magnetic circuits-</p> <p>Series and parallel magnetic circuits with composite materials, numerical problems.</p>	1 2
2.2	<p>Electromagnetic Induction: Faraday's laws, problems, Lenz's law-statically induced and dynamically induced emfs -</p> <p>Self-inductance and mutual inductance, coefficient of coupling</p>	1 2
2.3	<p>Alternating Current fundamentals: Generation of alternating voltages-Representation of sinusoidal waveforms: frequency, period, Average, RMS values and form factor of waveforms-Numerical Problems.</p>	2
3	AC Circuits	

3.1	<p>AC Circuits: Phasor representation of sinusoidal quantities. Trigonometric, Rectangular, Polar and complex forms.</p> <p>Analysis of simple AC circuits: Purely resistive, inductive & capacitive circuits; Inductive and capacitive reactance, concept of impedance. Average Power, Power factor.</p> <p>Analysis of RL, RC and RLC series circuits-active, reactive and apparent power.</p> <p>Simple numerical problems.</p>	1 2 1 2
3.2	<p>Three phase AC systems: Generation of three phase voltages; advantages of three phase systems, star and delta connections (balanced only), relation between line and phase voltages, line and phase currents- Numerical problems.</p>	2
4	Introduction to Semiconductor devices	
4.1	Evolution of electronics – Vacuum tubes to nano electronics (In evolutionary perspective only)	1
4.2	Resistors, Capacitors and Inductors: types, specifications. Standard values, color coding (No constructional features)	2
4.3	PN Junction diode: Principle of operation, V-I characteristics, principle of avalanche breakdown	2
4.4	Bipolar Junction Transistors: PNP and NPN structures, Principle of operation, relation between current gains in CE, CB and CC, input and output characteristics of common emitter configuration	3
5	Basic electronic circuits and instrumentation	
5.1	Rectifiers and power supplies: Block diagram description of a dc power supply, Working of a full wave bridge rectifier, capacitor filter (no analysis), working of simple zener voltage regulator	3
5.2	Amplifiers: Block diagram of Public Address system, Circuit diagram and working of common emitter (RC coupled) amplifier with its frequency response, Concept of voltage divider biasing	4
5.3	Electronic Instrumentation: Block diagram of an electronic instrumentation system	2
6	Introduction to Communication Systems	
6.1	Evolution of communication systems – Telegraphy to 5G	1

6.2	Radio communication: principle of AM & FM, frequency bands used for various communication systems, block diagram of super heterodyne receiver, Principle of antenna – radiation from accelerated charge	4
6.3	Mobile communication: basic principles of cellular communications, principle and block diagram of GSM.	2

Suggested Simulation Assignments for Basic Electronics Engineering

1. Plot V-I characteristics of Si and Ge diodes on a simulator
2. Plot Input and Output characteristics of BJT on a simulator
3. Implementation of half wave and full wave rectifiers
4. Simulation of RC coupled amplifier with the design supplied
5. Generation of AM signal

Note: The simulations can be done on open tools such as QUCS, KiCad, GNURadio or similar software to augment the understanding.

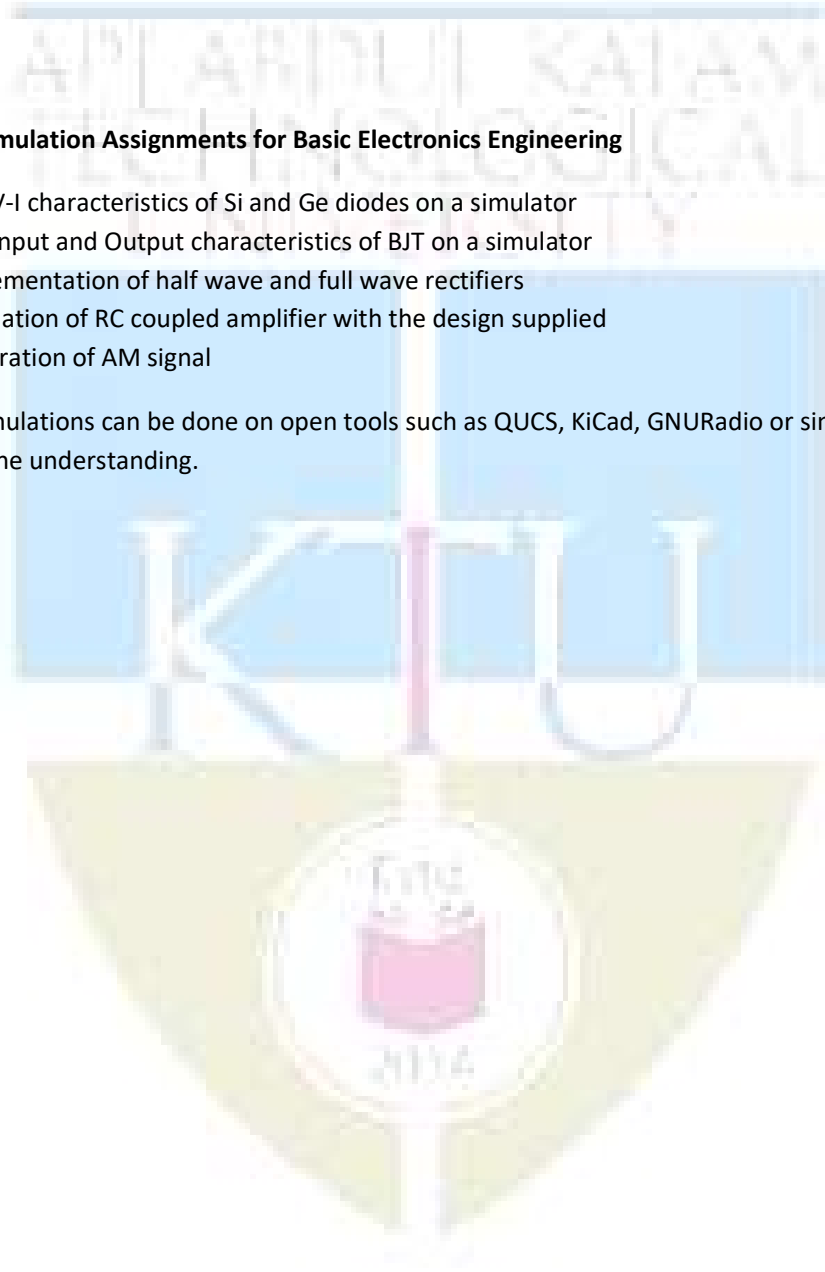

HUN 102	PROFESSIONAL COMMUNICATION	CATEGORY	L	T	P	CREDIT
		MNC	2	0	2	--

Preamble: Clear, precise, and effective communication has become a *sine qua non* in today's information-driven world given its interdependencies and seamless connectivity. Any aspiring professional cannot but master the key elements of such communication. The objective of this course is to equip students with the necessary skills to listen, read, write, and speak so as to comprehend and successfully convey any idea, technical or otherwise, as well as give them the necessary polish to become persuasive communicators.

Prerequisite: None

Course Outcomes: After the completion of the course the student will be able to

CO 1	Develop vocabulary and language skills relevant to engineering as a profession
CO 2	Analyze, interpret and effectively summarize a variety of textual content
CO 3	Create effective technical presentations
CO 4	Discuss a given technical/non-technical topic in a group setting and arrive at generalizations/consensus
CO 5	Identify drawbacks in listening patterns and apply listening techniques for specific needs
CO 6	Create professional and technical documents that are clear and adhering to all the necessary conventions

Mapping of course outcomes with program outcomes

	PO 1	PO 2	PO 3	PO 4	PO 5	PO 6	PO 7	PO 8	PO 9	PO 10	PO 11	PO 12
CO 1										3		2
CO 2										1		3
CO 3						1			1	3		
CO 4										3		1
CO 5		1							2	3		
CO 6	1					1			1	3		

Mark distribution

Total Marks	CIE	ESE	ESE Duration
100	50	50	2 hours

Continuous Internal Evaluation

Total Marks: 50

Attendance	: 10 marks
Regular assessment	: 25 marks
Series test (one test only, should include verbal aptitude for placement and higher studies, this test will be conducted for 50 marks and reduced to 15)	: 15 marks

Regular assessment

Project report presentation and Technical presentation through PPT	: 7.5 marks
Listening Test	: 5 marks
Group discussion/mock job interview	: 7.5 marks
Resume submission	: 5 marks

End Semester Examination

Total Marks: 50, Time: 2 hrs.

Course Level Assessment Questions

Course Outcome 1 (CO1):

1. List down the ways in which gestures affect verbal communication.
2. Match the words and meanings
Ambiguous promotion
Bona fide referring to whole
Holistic not clear
Exaltation genuine
3. Expand the following Compound Nouns - a. Water supply. b. Object recognition. c. Steam turbine

Course Outcome 2 (CO2)

1. Read the passage below and prepare notes:

Mathematics, rightly viewed, possesses not only truth, but supreme beauty—a beauty cold and austere, like that of sculpture, without appeal to any part of our weaker nature, without the gorgeous trappings of painting or music, yet sublimely pure, and capable of a stern perfection such as only the greatest art can show. The true spirit of delight, the exaltation, the sense of being more than man, which is the touchstone of the highest excellence, is to be found in mathematics as surely as in poetry. What is best in mathematics deserves not merely to be learnt as a task, but to be assimilated as a part of daily thought, and brought again and again before the mind with ever-renewed encouragement. Real life is, to most men, a long second-best, a perpetual compromise between the ideal and the possible; but the world of pure reason knows no compromise, no practical limitations, no barrier to the creative activity embodying in splendid edifices the passionate aspiration after the perfect from which all great work springs. Remote from human passions, remote even from the pitiful facts of nature, the generations have gradually created an ordered cosmos, where pure thought can dwell as in its natural home, and where one, at least, of our nobler impulses can escape from the dreary exile of the actual world.

So little, however, have mathematicians aimed at beauty, that hardly anything in their work has had this conscious purpose. Much, owing to irrepressible instincts, which were better than avowed

beliefs, has been moulded by an unconscious taste; but much also has been spoilt by false notions of what was fitting. The characteristic excellence of mathematics is only to be found where the reasoning is rigidly logical: the rules of logic are to mathematics what those of structure are to architecture. In the most beautiful work, a chain of argument is presented in which every link is important on its own account, in which there is an air of ease and lucidity throughout, and the premises achieve more than would have been thought possible, by means which appear natural and inevitable. Literature embodies what is general in particular circumstances whose universal significance shines through their individual dress; but mathematics endeavours to present whatever is most general in its purity, without any irrelevant trappings.

How should the teaching of mathematics be conducted so as to communicate to the learner as much as possible of this high ideal? Here experience must, in a great measure, be our guide; but some maxims may result from our consideration of the ultimate purpose to be achieved.

- From "On the teaching of mathematics" – Bertrand Russell

2. Enumerate the advantages and disadvantages of speed reading. Discuss how it can impact comprehension.

Course Outcome 3(CO3):

1. What are the key elements of a successful presentation?
2. Elucidate the importance of non-verbal communication in making a presentation
3. List out the key components in a technical presentation.

Course Outcome 4 (CO4):

1. Discuss: 'In today's world, being a good listener is more important than being a good Speaker.'
2. Listen to a video/live group discussion on a particular topic, and prepare a brief summary of the proceedings.
3. List the do's and don'ts in a group discussion.

Course Outcome 5 (CO5):

1. Watch a movie clip and write the subtitles for the dialogue.
2. What do you mean by barriers to effective listening? List ways to overcome each of these.
3. What are the different types of interviews? How are listening skills particularly important in Skype/telephonic interviews?

Course Outcome 6 (CO6):

1. Explain the basic structure of a technical report.
2. You have been offered an internship in a much sought-after aerospace company and are very excited about it. However, the dates clash with your series tests. Write a letter to the Manager – University Relations of the company asking them if they can change the dates to coincide with your vacation.
3. You work in a well-reputed aerospace company as Manager – University Relations. You are in charge of offering internships. A student has sent you a letter requesting you to change the dates allotted to him since he has series exams at that time. But there are no vacancies available during the period he has requested for. Compose an e-mail informing him of this and suggest that he try to arrange the matter with his college.

Syllabus

Module 1

Use of language in communication: Significance of technical communication Vocabulary Development: technical vocabulary, vocabulary used in formal letters/emails and reports, sequence words, misspelled words, compound words, finding suitable synonyms, paraphrasing, verbal analogies. Language Development: subject-verb agreement, personal passive voice, numerical adjectives, embedded sentences, clauses, conditionals, reported speech, active/passive voice.

Technology-based communication: Effective email messages, slide presentations, editing skills using software. Modern day research and study skills: search engines, repositories, forums such as Git Hub, Stack Exchange, OSS communities (MOOC, SWAYAM, NPTEL), and Quora; Plagiarism

Module 2

Reading, Comprehension, and Summarizing: Reading styles, speed, valuation, critical reading, reading and comprehending shorter and longer technical articles from journals, newspapers, identifying the various transitions in a text, SQ3R method, PQRS method, speed reading. Comprehension: techniques, understanding textbooks, marking and underlining, Note-taking: recognizing non-verbal cues.

Module 3

Oral Presentation: Voice modulation, tone, describing a process, Presentation Skills: Oral presentation and public speaking skills, business presentations, Preparation: organizing the material, self-Introduction, introducing the topic, answering questions, individual presentation practice, presenting visuals effectively.

Debate and Group Discussions: introduction to Group Discussion (GD), differences between GD and debate; participating GD, understanding GD, brainstorming the topic, questioning and clarifying, GD strategies, activities to improve GD skills

Module 4

Listening and Interview Skills Listening: Active and Passive listening, listening: for general content, to fill up information, intensive listening, for specific information, to answer, and to understand. Developing effective listening skills, barriers to effective listening, listening to longer technical talks, listening to classroom lectures, talks on engineering /technology, listening to documentaries and making notes, TED talks.

Interview Skills: types of interviews, successful interviews, interview etiquette, dress code, body language, telephone/online (skype) interviews, one-to-one interview & panel interview, FAQs related to job interviews

Module 5

Formal writing: Technical Writing: differences between technical and literary style. Letter Writing (formal, informal and semi formal), Job applications, Minute preparation, CV preparation (differences between Bio-Data, CV and Resume), and Reports. Elements of style, Common Errors in Writing: describing a process, use of sequence words, Statements of Purpose, Instructions, Checklists.

Analytical and issue-based Essays and Report Writing: basics of report writing; Referencing Style (IEEE Format), structure of a report; types of reports, references, bibliography.

Lab Activities

Written: Letter writing, CV writing, Attending a meeting and Minute Preparation, Vocabulary Building

Spoken: Phonetics, MMFS (Multimedia Feedback System), Mirroring, Elevator Pitch, telephone etiquette, qualities of a good presentation with emphasis on body language and use of visual aids.

Listening: Exercises based on audio materials like radio and podcasts. Listening to Song. practice and exercises.

Reading: Speed Reading, Reading with the help of Audio Visual Aids, Reading Comprehension Skills

Mock interview and Debate/Group Discussion: concepts, types, Do's and don'ts- intensive practice

Reference Books

1. English for Engineers and Technologists (Combined edition, Vol. 1 and 2), Orient Blackswan 2010.
2. Meenakshi Raman and Sangeetha Sharma, "Technical Communication: Principles and Practice", 2nd Edition, Oxford University Press, 2011
3. Stephen E. Lucas, "The Art of Public Speaking", 10th Edition; McGraw Hill Education, 2012.
4. Ashraf Rizvi, "Effective Technical Communication", 2nd Edition, McGraw Hill Education, 2017.
5. William Strunk Jr. & E.B. White, "The Elements of Style", 4th Edition, Pearson, 1999.
6. David F. Beer and David McMurrey, Guide to writing as an Engineer, John Willey. New York, 2004.
7. Goodheart-Willcox, "Professional Communication", First Edition, 2017.
8. Training in Interpersonal Skills: Tips for Managing People at Work, Pearson Education, India, 6 edition, 2015.
9. The Ace of Soft Skills: Attitude, Communication and Etiquette for Success, Pearson Education; 1 edition, 2013.
10. Anand Ganguly, "Success in Interview", RPH, 5th Edition, 2016.
11. Raman Sharma, "Technical Communications", Oxford Publication, London, 2004.

EST 102	PROGRAMING IN C	CATEGORY	L	T	P	CREDIT	YEAR OF INTRODUCTION
		ESC	2	1	2	4	2019

Preamble: The syllabus is prepared with the view of preparing the Engineering Graduates capable of writing readable C programs to solve computational problems that they may have to solve in their professional life. The course content is decided to cover the essential programming fundamentals which can be taught within the given slots in the curriculum. This course has got 2 Hours per week for practicing programming in C. A list showing 24 mandatory programming problems are given at the end. The instructor is supposed to give homework/assignments to write the listed programs in the rough record as and when the required theory part is covered in the class. The students are expected to come prepared with the required program written in the rough record for the lab classes.

Prerequisite: NIL

Course Outcomes: After the completion of the course the student will be able to

CO 1	Analyze a computational problem and develop an algorithm/flowchart to find its solution
CO 2	Develop readable* C programs with branching and looping statements, which uses Arithmetic, Logical, Relational or Bitwise operators.
CO 3	Write readable C programs with arrays, structure or union for storing the data to be processed
CO 4	Divide a given computational problem into a number of modules and develop a readable multi-function C program by using recursion if required, to find the solution to the computational problem
CO 5	Write readable C programs which use pointers for array processing and parameter passing
CO 6	Develop readable C programs with files for reading input and storing output

readable* - readability of a program means the following:

1. Logic used is easy to follow
2. Standards to be followed for indentation and formatting
3. Meaningful names are given to variables
4. Concise comments are provided wherever needed

Mapping of course outcomes with program outcomes

	PO1	PO2	PO3	PO4	PO5	PO6	PO7	PO8	PO9	PO10	PO11	PO12
CO1	☑	☑	☑	☑		☑				☑	☑	☑
CO2	☑	☑	☑	☑	☑					☑		☑
CO3	☑	☑	☑	☑	☑					☑		☑
CO4	☑	☑	☑	☑	☑					☑	☑	☑
CO5	☑	☑			☑					☑		☑
CO6	☑	☑			☑					☑		☑

Assessment Pattern

Bloom's Category	Continuous Assessment Tests		End Semester Examination Marks
	Test 1 (Marks)	Test 2 (Marks)	
Remember	15	10	25
Understand	10	15	25
Apply	20	20	40
Analyse	5	5	10
Evaluate			
Create			

Mark distribution

Total Marks	CIE Marks	ESE Marks	ESE Duration
150	50	100	3 hours

Continuous Internal Evaluation Pattern:

Attendance	: 10 marks
Continuous Assessment Test 1 (for theory, for 2 hrs)	: 20 marks
Continuous Assessment Test 2 (for lab, internal examination, for 2 hrs)	: 20 marks

Internal Examination Pattern: There will be two parts; Part A and Part B. Part A contains 5 questions with 2 questions from each module (2.5 modules x 2 = 5), having 3 marks for each question. Students should answer all questions. Part B also contains 5 questions with 2 questions from each module (2.5 modules x 2 = 5), of which a student should answer any one. The questions should not have sub-divisions and each one carries 7 marks.

End Semester Examination Pattern: There will be two parts; Part A and Part B. Part A contains 10 questions with 2 questions from each module, having 3 marks for each question. Students should answer all questions. Part B contains 2 questions from each module of which a student should answer any one. Each question can have maximum 2 sub-divisions and carry 14 marks.

Sample Course Level Assessment Questions

Course Outcome 1 (CO1): Write an algorithm to check whether largest of 3 natural numbers is prime or not. Also, draw a flowchart for solving the same problem.

Course Outcome 2 (CO2): Write an easy to read C program to process a set of n natural numbers and to find the largest even number and smallest odd number from the given set of numbers. The program should not use division and modulus operators.

Course Outcome 3 (CO3): Write an easy to read C program to process the marks obtained by n students of a class and prepare their rank list based on the sum of the marks obtained. There are 3 subjects for which examinations are conducted and the third subject is an elective where a student is allowed to take any one of the two courses offered.

Course Outcome 4 (CO4): Write an easy to read C program to find the value of a mathematical function f which is defined as follows. $f(n) = n! / (\text{sum of factors of } n)$, if n is not prime and $f(n) = n! / (\text{sum of digits of } n)$, if n is prime.

Course Outcome 5 (CO5): Write an easy to read C program to sort a set of n integers and to find the number of unique numbers and the number of repeated numbers in the given set of numbers. Use a function which takes an integer array of n elements, sorts the array using the Bubble Sorting Technique and returns the number of unique numbers and the number of repeated numbers in the given array.

Course Outcome 6 (CO6): Write an easy to read C program to process a text file and to print the Palindrome words into an output file.

Model Question paper

QP CODE:

PAGES:3

Reg No: _____

Name : _____

**APJ ABDUL KALAM TECHNOLOGICAL UNIVERSITY FIRST SEMESTER B.TECH DEGREE EXAMINATION,
MONTH & YEAR**

Course Code: EST 102

Course Name: Programming in C (Common to all programs)

Max.Marks:100

Duration: 3 Hours

PART A

Answer all Questions. Each question carries 3 Marks

1. Write short note on processor and memory in a computer.
2. What are the differences between compiled and interpreted languages? Give example for each.
3. Write a C program to read a Natural Number through keyboard and to display the reverse of the given number. For example, if "3214567" is given as input, the output to be shown is "7654123".
4. Is it advisable to use *goto* statements in a C program? Justify your answer.
5. Explain the different ways in which you can *declare & initialize* a single dimensional array.
6. Write a C program to read a sentence through keyboard and to display the count of white spaces in the given sentence.
7. What are the advantages of using functions in a program?
8. With a simple example program, explain *scope* and *life time* of variables in C.
9. Write a function in C which takes the address of a single dimensional array (containing a finite sequence of numbers) and the number of numbers stored in the array as arguments and stores the numbers in the same array in reverse order. Use pointers to access the elements of the array.
10. With an example, explain the different modes of opening a file. (10x3=30)

Part B

Answer any one Question from each module. Each question carries 14 Marks

11. (a) Draw a flow chart to find the position of an element in a given sequence, using linear searching technique. With an example explain how the flowchart finds the position of a given element. (10)
- (b) Write a pseudo code representing the flowchart for linear searching. (4)

OR

12. (a) With the help of a flow chart, explain the bubble sort operation. Illustrate with an example. **(10)**
(b) Write an algorithm representing the flowchart for bubble sort. **(4)**

13. (a) Write a C program to read an English Alphabet through keyboard and display whether the given Alphabet is in upper case or lower case. **(6)**
(b) Explain how one can use the builtin function in C, *scanf* to read values of different data types. Also explain using examples how one can use the builtin function in C, *printf* for text formatting. **(8)**

OR

14. (a) With suitable examples, explain various operators in C. **(10)**
(b) Explain how characters are stored and processed in C. **(4)**

15. (a) Write a function in C which takes a 2-Dimensional array storing a matrix of numbers and the order of the matrix (number of rows and columns) as arguments and displays the sum of the elements stored in each row. **(6)**
(b) Write a C program to check whether a given matrix is a diagonal matrix. **(8)**

OR

16. (a) Without using any builtin string processing function like *strlen*, *strcat* etc., write a program to concatenate two strings. **(8)**
(b) Write a C program to perform bubble sort. **(6)**

17. (a) Write a function namely *myFact* in C to find the factorial of a given number. Also, write another function in C namely *nCr* which accepts two positive integer parameters *n* and *r* and returns the value of the mathematical function $C(n,r) (n! / (r! \times (n - r)!))$. The function *nCr* is expected to make use of the factorial function *myFact*. **(10)**
(b) What is recursion? Give an example. **(4)**

OR

18. (a) With a suitable example, explain the differences between a structure and a union in C. **(6)**
(b) Declare a structure namely *Student* to store the details (*roll number*, *name*, *mark_for_C*) of a student. Then, write a program in C to find the average mark obtained by the students in a class for the subject *Programming in C* (using the field *mark_for_C*). Use array of structures to store the required data **(8)**

19. (a) With a suitable example, explain the concept of pass by reference. **(6)**
(b) With a suitable example, explain how pointers can help in changing the content of a single dimensionally array passed as an argument to a function in C. **(8)**

OR

20. (a) Differentiate between sequential files and random access files? **(4)**

(b) Using the prototypes explain the functionality provided by the following functions. (10)

rewind()

i. *fseek()*

ii. *ftell()*

iii. *fread()*

iv. *fwrite()*

(14X5=70)

SYLLABUS

Programming in C (Common to all disciplines)

Module 1

Basics of Computer Hardware and Software

Basics of Computer Architecture: processor, Memory, Input & Output devices

Application Software & System software: Compilers, interpreters, High level and low level languages

Introduction to structured approach to programming, Flow chart Algorithms, Pseudo code (*bubble sort, linear search - algorithms and pseudocode*)

Module 2

Program Basics

Basic structure of C program: Character set, Tokens, Identifiers in C, Variables and Data Types, Constants, Console IO Operations, printf and scanf

Operators and Expressions: Expressions and Arithmetic Operators, Relational and Logical Operators, Conditional operator, size of operator, Assignment operators and Bitwise Operators. Operators Precedence

Control Flow Statements: If Statement, Switch Statement, Unconditional Branching using goto statement, While Loop, Do While Loop, For Loop, Break and Continue statements. (Simple programs covering control flow)

Module 3

Arrays and strings

Arrays Declaration and Initialization, 1-Dimensional Array, 2-Dimensional Array

String processing: In built String handling functions (strlen, strcpy, strcat and strcmp, puts, gets)

Linear search program, bubble sort program, simple programs covering arrays and strings

Module 4

Working with functions

Introduction to modular programming, writing functions, formal parameters, actual parameters Pass by Value, Recursion, Arrays as Function Parameters structure, union, Storage Classes, Scope and life time of variables, *simple programs using functions*

Module 5

Pointers and Files

Basics of Pointer: declaring pointers, accessing data through pointers, NULL pointer, array access using pointers, pass by reference effect

File Operations: open, close, read, write, append

Sequential access and random access to files: In built file handling functions (*rewind()*, *fseek()*, *ftell()*, *feof()*, *fread()*, *fwrite()*), simple programs covering pointers and files.

Text Books

1. Schaum Series, Gottfried B.S., Tata McGraw Hill, Programming with C
2. E. Balagurusamy, McGraw Hill, Programming in ANSI C
3. Asok N Kamthane, Pearson, Programming in C
4. Anita Goel, Pearson, Computer Fundamentals

Reference Books

1. Anita Goel and Ajay Mittal, Pearson, Computer fundamentals and Programming in C
2. Brian W. Kernighan and Dennis M. Ritchie, Pearson, C Programming Language
3. Rajaraman V, PHI, Computer Basics and Programming in C
4. Yashavant P, Kanetkar, BPB Publications, Let us C

Course Contents and Lecture Schedule

Module 1: Basics of Computer Hardware and Software		(7 hours)
1.1	Basics of Computer Architecture: Processor, Memory, Input & Output devices	2 hours
1.2	Application Software & System software: Compilers, interpreters, High level and low level languages	2 hours
1.3	Introduction to structured approach to programming, Flow chart	1 hours
1.4	Algorithms, Pseudo code (<i>bubble sort, linear search - algorithms and pseudocode</i>)	2 hours
Module 2: Program Basics		(8 hours)
2.1	Basic structure of C program: Character set, Tokens, Identifiers in C, Variables and Data Types, Constants, Console IO Operations, printf and scanf	2 hours
2.2	Operators and Expressions: Expressions and Arithmetic Operators, Relational and Logical Operators, Conditional operator, sizeof operator, Assignment operators and Bitwise Operators. Operators Precedence	2 hours

2.3	Control Flow Statements: If Statement, Switch Statement, Unconditional Branching using goto statement, While Loop, Do While Loop, For Loop, Break and Continue statements. <i>(Simple programs covering control flow)</i>	4 hours
Module 3: Arrays and strings:		(6 hours)
3.1	Arrays Declaration and Initialization, 1-Dimensional Array, 2-Dimensional Array	2 hours
3.2	String processing: In built String handling functions(<i>strlen, strcpy, strcat and strcmp, puts, gets</i>)	2 hours
3.3	Linear search program, bubble sort program, <i>simple programs covering arrays and strings</i>	3 hours
Module 4: Working with functions		(7 hours)
4.1	Introduction to modular programming, writing functions, formal parameters, actual parameters	2 hours
4.2	Pass by Value, Recursion, Arrays as Function Parameters	2 hours
4.3	structure, union, Storage Classes, Scope and life time of variables, <i>simple programs using functions</i>	3 hours
Module 5: Pointers and Files		(7 hours)
5.1	Basics of Pointer: declaring pointers, accessing data through pointers, NULL pointer, array access using pointers, pass by reference effect	3 hours
5.2	File Operations: open, close, read, write, append	1 hours
5.3	Sequential access and random access to files: In built file handling functions (<i>rewind(), fseek(), ftell(), feof(), fread(), fwrite()</i>), <i>simple programs covering pointers and files.</i>	2 hours

C PROGRAMMING LAB (Practical part of EST 102, Programming in C)

Assessment Method: The Academic Assessment for the Programming lab should be done internally by the College. The assessment shall be made on 50 marks and the mark is divided as follows: Practical Records/Outputs - 20 marks (internal by the College), Regular Lab Viva - 5 marks (internal by the College), Final Practical Exam – 25 marks (internal by the College).

The mark obtained out of 50 will be converted into equivalent proportion out of 20 for CIE computation.

LIST OF LAB EXPERIMENTS

1. Familiarization of Hardware Components of a Computer
2. Familiarization of Linux environment – How to do Programming in C with Linux
3. Familiarization of console I/O and operators in C
 - i) Display “Hello World”
 - ii) Read two numbers, add them and display their sum
 - iii) Read the radius of a circle, calculate its area and display it
 - iv) Evaluate the arithmetic expression $((a - b / c * d + e) * (f + g))$ and display its solution. Read the values of the variables from the user through console.
4. Read 3 integer values and find the largest among them.
5. Read a Natural Number and check whether the number is prime or not
6. Read a Natural Number and check whether the number is Armstrong or not
7. Read n integers, store them in an array and find their sum and average
8. Read n integers, store them in an array and search for an element in the array using an algorithm for Linear Search
9. Read n integers, store them in an array and sort the elements in the array using Bubble Sort algorithm
10. Read a string (word), store it in an array and check whether it is a palindrome word or not.
11. Read two strings (each one ending with a \$ symbol), store them in arrays and concatenate them without using library functions.
12. Read a string (ending with a \$ symbol), store it in an array and count the number of vowels, consonants and spaces in it.
13. Read two input each representing the distances between two points in the Euclidean space, store these in structure variables and add the two distance values.
14. Using structure, read and print data of n employees (*Name, Employee Id and Salary*)
15. Declare a union containing 5 string variables (*Name, House Name, City Name, State and Pin code*) each with a length of C_SIZE (user defined constant). Then, read and display the address of a person using a variable of the union.
16. Find the factorial of a given Natural Number n using recursive and non recursive functions
17. Read a string (word), store it in an array and obtain its reverse by using a user defined function.
18. Write a menu driven program for performing matrix addition, multiplication and finding the transpose. Use functions to (i) read a matrix, (ii) find the sum of two matrices, (iii) find the product of two matrices, (iv) find the transpose of a matrix and (v) display a matrix.
19. Do the following using pointers
 - i) add two numbers
 - ii) swap two numbers using a user defined function
20. Input and Print the elements of an array using pointers
21. Compute sum of the elements stored in an array using pointers and user defined function.
22. Create a file and perform the following
 - iii) Write data to the file
 - iv) Read the data in a given file & display the file content on console
 - v) append new data and display on console
23. Open a text input file and count number of characters, words and lines in it; and store the results in an output file.

CYL 120	ENGINEERING CHEMISTRY LAB	CATEGORY	L	T	P	CREDIT
		BSC	0	0	2	1

Preamble: To impart scientific approach and to familiarize with the experiments in chemistry relevant for research projects in higher semesters

Prerequisite: Experiments in chemistry introduced at the plus two levels in schools

Course outcomes: After the completion of the course the students will be able to

CO 1	Understand and practice different techniques of quantitative chemical analysis to generate experimental skills and apply these skills to various analyses
CO 2	Develop skills relevant to synthesize organic polymers and acquire the practical skill to use TLC for the identification of drugs
CO 3	Develop the ability to understand and explain the use of modern spectroscopic techniques for analysing and interpreting the IR spectra and NMR spectra of some organic compounds
CO 4	Acquire the ability to understand, explain and use instrumental techniques for chemical analysis
CO 5	Learn to design and carry out scientific experiments as well as accurately record and analyze the results of such experiments
CO 6	Function as a member of a team, communicate effectively and engage in further learning. Also understand how chemistry addresses social, economical and environmental problems and why it is an integral part of curriculum

Mapping of course outcomes with program outcomes

	PO 1	PO 2	PO 3	PO 4	PO 5	PO 6	PO 7	PO 8	PO 9	PO 10	PO 11	PO 12
CO 1	3				2							3
CO 2	3				3							3
CO 3	3				3							3
CO 4	3				3							3
CO 5	3				1							3
CO 6	3				1							3

Mark distribution

Total Marks	CIE marks	ESE marks	ESE Duration(Internal)
100	100	-	1 hour

Continuous Internal Evaluation Pattern:

Attendance	: 20 marks
Class work/ Assessment/Viva-voce	: 50 marks
End semester examination (Internally by college)	: 30 marks

End Semester Examination Pattern: Written Objective Examination of one hour

SYLLABUS**LIST OF EXPERIMENTS (MINIMUM 8 MANDATORY)**

1. Estimation of total hardness of water-EDTA method
2. Potentiometric titration
3. Determination of cell constant and conductance of solutions.
4. Calibration of pH meter and determination of pH of a solution
5. Estimation of chloride in water
6. Identification of drugs using TLC
7. Determination of wavelength of absorption maximum and colorimetric estimation of Fe^{3+} in solution
8. Determination of molar absorptivity of a compound (KMnO_4 or any water soluble food colorant)
9. Synthesis of polymers (a) Urea-formaldehyde resin (b) Phenol-formaldehyde resin
10. Estimation of iron in iron ore
11. Estimation of copper in brass
12. Estimation of dissolved oxygen by Winkler's method
13. (a) Analysis of IR spectra (minimum 3 spectra) (b) Analysis of ^1H NMR spectra (minimum 3 spectra)
14. Flame photometric estimation of Na^+ to find out the salinity in sand
15. Determination of acid value of a vegetable oil
16. Determination of saponification of a vegetable oil

Reference Books

1. G. Svehla, B. Sivasankar, "Vogel's Qualitative Inorganic Analysis", Pearson, 2012.
2. R. K. Mohapatra, "Engineering Chemistry with Laboratory Experiments", PHI Learning, 2017.
3. Muhammed Arif, "Engineering Chemistry Lab Manual", Owl publishers, 2019.
4. Ahad J., "Engineering Chemistry Lab manual", Jai Publications, 2019.
5. Roy K Varghese, "Engineering Chemistry Laboratory Manual", Crownplus Publishers, 2019.
6. Soney C George, Rino Laly Jose, "Lab Manual of Engineering Chemistry", S. Chand & Company Pvt Ltd, New Delhi, 2019.

ESL 130	ELECTRICAL & ELECTRONICS WORKSHOP	CATEGORY	L	T	P	CREDIT	YEAR OF INTRODUCTION
		ESC	0	0	2	1	2019

Preamble: Electrical Workshop is intended to impart skills to plan and carry out simple electrical wiring. It is essential for the practicing engineers to identify the basic practices and safety measures in electrical wiring.

Prerequisite: NIL

Course Outcomes: After the completion of the course the student will be able to

CO 1	Demonstrate safety measures against electric shocks.
CO 2	Identify the tools used for electrical wiring, electrical accessories, wires, cables, batteries and standard symbols
CO 3	Develop the connection diagram, identify the suitable accessories and materials necessary for wiring simple lighting circuits for domestic buildings
CO 4	Identify and test various electronic components
CO 5	Draw circuit schematics with EDA tools
CO 6	Assemble and test electronic circuits on boards
CO 7	Work in a team with good interpersonal skills

Mapping of course outcomes with program outcomes

	PO 1	PO 2	PO 3	PO 4	PO 5	PO 6	PO 7	PO 8	PO 9	PO 10	PO 11	PO 12
CO 1	-	-	-	-	-	3	-	-	-	-	-	1
CO 2	2	-	-	-	-	-	-	-	-	1	-	-
CO 3	2	-	-	1	-	1	-	1	2	2	-	2
CO 4	3	-	-	-	-	-	-	-	-	-	-	2
CO 5	3	-	-	-	2	-	-	-	-	-	-	2
CO 6	3	-	-	-	2	-	-	-	-	-	-	1
CO 7	-	-	-	-	-	-	-	-	3	2	-	2

Mark distribution

Total Marks	CIE	ESE	ESE Duration(Internal)
100	100	-	1 hour

Continuous Internal Evaluation Pattern:

Attendance	: 20 marks
Class work/ Assessment/Viva-voce	: 50 marks
End semester examination (Internally by college)	: 30 marks

End Semester Examination Pattern: Written Objective Examination of one hour

Syllabus

PART 1

ELECTRICAL

List of Exercises / Experiments

1. a) Demonstrate the precautionary steps adopted in case of Electrical shocks.
b) Identify different types of cables, wires, switches, fuses, fuse carriers, MCB, ELCB and MCCB with ratings.
2. Wiring of simple light circuit for controlling light/ fan point (PVC conduit wiring)
3. Wiring of light/fan circuit using Two way switches . (Staircase wiring)
4. Wiring of Fluorescent lamps and light sockets (6A) with a power circuit for controlling power device. (16A socket)
5. Wiring of power distribution arrangement using single phase MCB distribution board with ELCB, main switch and Energy meter.
6. a) Identify different types of batteries with their specifications.
b) Demonstrate the Pipe and Plate Earthing Schemes using Charts/Site Visit.

PART II

ELECTRONICS

List of Exercises / Experiments (Minimum of 7 mandatory)

1. Familiarization/Identification of electronic components with specification (Functionality, type, size, colour coding, package, symbol, cost etc. [Active, Passive, Electrical, Electronic, Electro-mechanical, Wires, Cables, Connectors, Fuses, Switches, Relays, Crystals, Displays, Fasteners, Heat sink etc.]

2. Drawing of electronic circuit diagrams using BIS/IEEE symbols and introduction to EDA tools (such as Dia or Xcircuit), Interpret data sheets of discrete components and IC's, Estimation and costing.
3. Familiarization/Application of testing instruments and commonly used tools. [Multimeter, Function generator, Power supply, DSO etc.] [Soldering iron, De-soldering pump, Pliers, Cutters, Wire strippers, Screw drivers, Tweezers, Crimping tool, Hot air soldering and de- soldering station etc.]
4. Testing of electronic components [Resistor, Capacitor, Diode, Transistor and JFET using multimeter.]
5. Inter-connection methods and soldering practice. [Bread board, Wrapping, Crimping, Soldering - types - selection of materials and safety precautions, soldering practice in connectors and general purpose PCB, Crimping.]
6. Printed circuit boards (PCB) [Types, Single sided, Double sided, PTH, Processing methods, Design and fabrication of a single sided PCB for a simple circuit with manual etching (Ferric chloride) and drilling.]
7. Assembling of electronic circuits using SMT (Surface Mount Technology) stations.
8. Assembling of electronic circuit/system on general purpose PCB, test and show the functioning (**Any Two circuits**).
 1. Fixed voltage power supply with transformer, rectifier diode, capacitor filter, zener/IC regulator.
 2. Square wave generation using IC 555 timer in IC base.
 3. Sine wave generation using IC 741 OP-AMP in IC base.
 4. RC coupled amplifier with transistor BC107.