

CODE	COURSE NAME	CATEGORY	L	T	P	CREDIT
MET302	HEAT & MASS TRANSFER	PCC	3	1	0	4

Preamble:

The objectives of the course are:

- To introduce the various modes of heat transfer and to develop methodologies for solving a wide variety of practical heat transfer problems
- To provide useful information concerning the performance and design of simple heat transfer systems
- Conceive the energy balance in any thermal practical situation involving heat transfer mechanisms.
- To introduce mass transfer.

Prerequisite: MET203 Mechanics of Fluids, MET202 Engineering Thermodynamics

Course Outcomes: After the completion of the course the student will be able to

CO 1	Apply principles of heat and mass transfer to engineering problems
CO 2	Analyse and obtain solutions to problems involving various modes of heat transfer
CO 3	Design heat transfer systems such as heat exchangers, fins, radiation shields etc.
CO 4	Define laminar and turbulent boundary layers and ability to formulate energy equation in flow systems.

Mapping of course outcomes with program outcomes

	PO 1	PO 2	PO 3	PO 4	PO 5	PO 6	PO 7	PO 8	PO 9	PO 10	PO 11	PO 12
CO 1	3	3	2									1
CO 2	3	3	3									2
CO 3	3	3	3									2
CO 4	3	3	3									2

Assessment Pattern

Bloom's Category	Continuous Assessment Tests		End Semester Examination
	1	2	
Remember	10	10	10
Understand	20	10	20
Apply	10	20	50
Analyse	10	10	20
Evaluate			
Create			

Mark distribution

Total Marks	CIE	ESE	ESE Duration
150	50	100	3 hours

Continuous Internal Evaluation Pattern:

Attendance	: 10marks
Continuous Assessment Test(2numbers)	: 25 marks
Assignment/Quiz/Course project	: 15marks

End Semester Examination Pattern: There will be two parts; Part A and Part B. Part A contain 10 questions with 2 questions from each module, having 3 marks for each question. Students should answer all questions. Part B contains 2 questions from each module of which student should answer any one. Each question can have maximum 2 sub-divisions and carry 14 marks.

Course Level Assessment Questions**Course Outcome 1 (CO1):**

1. A furnace wall is made up of three layers of thicknesses 250 mm, 100 mm and 150 mm with thermal conductivities of 1.65 W/m.K and 9.2 W/m.K respectively. The inside is exposed to gases at 1250 °C with a convection coefficient of 25 W/m².K. and the inside surface is at 1100 °C, the outside surface is exposed to air at 25 °C with convection coefficient of 12 W/m².K. Determine (a) the unknown thermal conductivity K (b) the overall heat transfer coefficient (c) all the intermediate temperatures?
2. Derive an expression for steady state temperature distribution in a slab with internal heat generation.
3. Dry air at 300 °C and 1 atm flows over a wet flat plate 600 mm. long at a velocity of 50 m/s. Calculate the mass transfer co-efficient of water vapour in air at the end of the plate. Take the diffusion co-efficient of water vapour in air, $D = 0.26 \times 10^{-4} \text{ m}^2/\text{s}$.

Course Outcome 2 (CO2)

1. Discuss the importance of non-dimensional numbers in heat transfer problems.
2. A hollow sphere ($k = 65 \text{ W/m.K}$) of 120 mm inner diameter and 350 mm outer diameter is covered 10 mm layer of insulation ($k = 10 \text{ W/m.K}$). The inside and outside temperatures are 500 °C and 50 °C respectively. Calculate the rate of heat flow through this sphere.

3. A steel ball (specific heat =0.46 kJ/kg.K, and thermal conductivity 35W/m.K) having 5 cm diameter and initially at a uniform temperature of 450 °C is suddenly placed in a control environment in which the temperature is maintained at 100 °C. Calculate the time required for the ball to attain a temperature of 150 °C.

Course Outcome 3(CO3):

1. Water at the rate of 4 kg/s is heated from 40 °C to 55°C in a shell and tube heat exchanger. On the shell side one pass is used with water as the heating fluid and at a mass flow rate of 2 kg/s, and entering the heat exchanger at 95 °C. The overall heat transfer coefficient is 1500 W/m²K. and the average water velocity in the 2 cm diameter tubes is 0.5 m/s. Because of space limitations, the tube length must not exceed 3 m. Calculate the number of tube passes, the number of tubes per pass and the length of the tubes, keeping in mind the design constraints.
2. Two large plates, one at 800 K and other at 600 K have emissivities 0.5 and 0.8 respectively. A radiation shield having an emissivity 0.1 on one side and emissivity 0.05 on the other side is placed between the plates. Calculate the heat transfer by radiation per square meter with and without the radiation shield.
3. A rectangular aluminum fin of thermal conductivity 200 W/m.K, 3mm. thick and 7.5 cm long protrudes out from a wall. The fin base is maintained at a temperature of 300 °C and the ambient temperature is 50 °C with heat transfer coefficient 10W/m²K. The tip of the fin is insulated. Calculate the heat transfer from the fin per unit depth of material.

Course Outcome 4 (CO4):

1. Explain velocity boundary layer and thermal boundary layer with neat sketches.
2. Air at 40 °C flows over a tube with a velocity of 30 m/s. The tube surface temperature is 120 °C. Calculate the heat transfer coefficient for the following cases:
 - (i) Tube is square with a side of 6 cm
 - (ii) Tube is circular cylinder with a diameter of 6 cm.
3. Air at 20 °C at atmospheric pressure flows over a flat plate at a velocity of 3 m/s. If the plate is 1 m wide and at 80 °C, calculate the following at $x = 300\text{mm}$.
 - i. Hydrodynamic boundary layer thickness
 - ii. Thermal boundary layer thickness
 - iii. Local friction coefficient
 - iv. Average heat transfer coefficient
 - v. Heat transfer rate

MODEL QUESTION PAPER

APJ ABDUL KALAM TECHNOLOGICAL UNIVERSITY

SIXTH SEMESTER MECHANICAL ENGINEERING

Heat and Mass Transfer-MET302

Maximum:100Marks

Duration: 3 hours

PART A

Answer all questions. Each question carries 3 marks

1. Discuss about the application of Heisler chart and Schmidt plot in heat transfer analysis.
2. How does a numerical solution method differ from analytical one? Explain.
3. What are the characteristics of a boundary layer?
4. Write the significance of Nusselt number.
5. What is meant by condensation heat transfer? How it differs from drop wise heat transfer?
6. What are the main factors to be considered for a heat exchanger design?
7. Explain about radiation shape factor.
8. What are the properties of blackbody?
9. Give two examples of mass transfer in day-to-day life.
10. Explain Ficks law of diffusion with suitable assumptions.

(10 X 3 = 30 Marks)

PART B**Answer one full question from each module****MODULE 1**

11.

a) Derive 3-dimensional unsteady state heat conduction equation with heat generation, in Cartesian co-ordinate system for anisotropic material. (7Marks)

b) A 3 mm diameter and 5m long electric wire is tightly wrapped with a 2 mm thick plastic cover whose thermal conductivity is $k = 0.15 \text{ W/m-K}$. Electrical measurements indicate that a current of 10 A passes through the wire and there is a voltage drop of 8 V along the wire. If the insulated wire is exposed to a medium at $T_\infty = 30^\circ\text{C}$ with a heat transfer coefficient of $h = 12 \text{ W/m}^2\text{-K}$, determine the temperature at the interface of the wire and the plastic cover in steady operation. Also state with reason, whether doubling the thickness of the plastic cover will increase or decrease heat transfer.

(7 Marks)

12.

a) Derive an expression for temperature distribution for 1-dimensional slab with varying thermal conductivity. Assume the variation of thermal conductivity of slab as $k = k_0(1+\beta t)$.

(7 Marks)

b) A square plate heater 15 cm x 15 cm is inserted between two slabs. Slab A is 2 cm thick ($k = 50\text{W/m-K}$) and Slab B is 1cm thick ($k = 0.2\text{W/m-K}$). The outside heat transfer coefficients on side A and side B are $200\text{W/m}^2\text{-K}$ and $50\text{W/m}^2\text{-K}$ respectively. The temperature of surrounding air is 25°C . If rating of heater is 1 KW, find (a) Maximum temperature in the system, and (b) outer surface temperature of the two slabs. (7Marks)

MODULE II

13.

a) Saturated propane at 300 K with a velocity of 25 cm/s flows over a flat plate of length $L=2 \text{ m}$. and width $w=1 \text{ m}$. maintained at uniform temperature of 400 K. Calculate the local heat transfer coefficient at 1 m. length and the average heat transfer coefficient from $L=0 \text{ m}$. to $L=2 \text{ m}$. Also find the heat transfer. (7Marks)

b) Hot air at atmospheric pressure and 80°C enters an 8 m. long uninsulated square duct of cross section 0.2 m. x 0.2 m. that passes through the attic of a house at a rate of $0.15\text{m}^3/\text{s}$. The duct is observed to be nearly isothermal at 60°C . Determine the exit temperature of the air. (7Marks)

14.

a) Air at 15°C , 35 m/s , flows through a hollow cylinder of 4 cm inner diameter and 6 cm outer diameter and leaves at 45°C . The tube passes through a room where the room temperature is 65°C and tube wall is maintained at 60°C . Calculate the heat transfer coefficient between the air and the inner tube. (7Marks)

b) Consider a $0.6\text{ m} \times 0.6\text{ m}$ thin square plate in a room at 30°C . One side of the plate is maintained at a temperature of 90°C , while the other side is insulated. Determine the rate of heat transfer from the plate by natural convection. If the emissivity of the surface is 1.0 , calculate the heat loss by radiation. Also calculate the percentage of heat loss by convection. (7Marks)

MODULE III

15.

a) A counter flow double pipe heat exchanger is to heat water from 20°C to 80°C at a rate of 1.2 kg/s . The heating is to be accomplished by geothermal water available at 170°C at a mass flow rate of 2 kg/s . The inner tube is thin walled and has a diameter of 1.5 cm . If the overall heat transfer coefficient of the heat exchanger is $640\text{ W/m}^2\text{-K}$, determine the length of the heat exchanger required to achieve the desired heating. Use ϵ -NTU method.

(8 Marks)

b) Derive an expression for LMTD of double pipe, parallel flow heat exchanger.

(6 Marks)

16.

a) Steam in the condenser of a power plant is to be condensed at a temperature of 30°C with cooling water from a nearby lake, which enters the tubes of the condenser at 14°C and leaves at 22°C . The surface area of the tubes is 45 m^2 and the overall heat transfer coefficient is $2100\text{ W/m}^2 \cdot ^{\circ}\text{C}$. Determine the mass flow rate of the cooling water needed and the rate of condensation of the steam in the condenser. (7Marks)

b) In a double pipe heat exchanger, hot fluid with a specific heat of 2300 J/kg enters at 380°C and leaves at 300°C . Cold fluid enters at 25°C and leaves at 210°C . Calculate the heat exchanger area required for (i) Counter flow and (ii) Parallel flow. Take overall heat transfer coefficient as $750\text{ W/m}^2\text{ K}$ and mass flow rate of hot fluid is 1 kg/s . (7Marks)

MODULE IV

17.

a) A 70 mm. thick metal plate with a circular hole of 35 mm. diameter along the thickness is maintained at a uniform temperature 250 °C. Find the loss of energy to the surroundings at 27 °C, assuming the two ends of the hole to be as parallel discs and the metallic surfaces and surroundings have blackbody characteristics. (6Marks)

b) Two large parallel planes with emissivities of 0.3 and 0.5 are maintained at temperatures of 527 °C and 127 °C respectively. A radiation shield having emissivities of 0.05 on both sides is placed between them. Calculate,

(i) Heat transfer rate between them without shield.

(ii) Heat transfer rate between them with shield.

(8 Marks)

18.

a) Two parallel plates of size 1.0 m. by 1.0 m. spaced 0.5 m apart are located in a very large room, the walls of which are maintained at a temperature of 27°C. One plate is maintained at a temperature of 900 °C and the other at 400 °C. Their emissivities are 0.2 and 0.5 respectively. If the plates exchange heat between themselves and the surroundings, find the net heat transfer to each plate and to the room. Consider only the plate surface facing each other.

(8 Marks)

b) Two rectangular surfaces are perpendicular to each other with a common edge of 2 m. The horizontal plane is 2 m. long and vertical plane is 3 m long. Vertical plane is at 1200 K and has an emissivity of 0.4. the horizontal plane is 18 °C and has an emissivity of 0.3. Determine the net heat exchange between the planes. (6 marks)

MODULE V

19.

a) Explain the analogy between heat and mass transfer.

(6 Marks)

b) Dry air at 30°C and 1 atm flows over a wet flat plate 600 mm. long at a velocity of 50 m/s. Calculate the mass transfer co-efficient of water vapour in air at the end of the plate. Take the diffusion co-efficient of water vapour in air, $D = 0.26 \times 10^{-4} \text{ m}^2/\text{s}$.

(8Marks)

20.

a) Gaseous hydrogen is stored at elevated pressure in a rectangular steel container of 10 mm. wall thickness. The molar concentration of hydrogen in steel at the inner surface is 2 kg mol/m^3 , while the concentration of hydrogen in steel at the outer surface is 0.5 kg mol/m^3 . The binary diffusion coefficient for hydrogen in steel is $0.26 \times 10^{-12} \text{ m}^2/\text{s}$. What is the mass flux of hydrogen through the steel? (8 Marks)

b) Explain the phenomenon of equimolar counter diffusion. Derive an expression for equimolar counter diffusion between two gases or liquids.

(6 Marks)

Syllabus

Module 1-

CONDUCTION HEAT TRANSFER

Introduction to heat transfer- thermodynamics and heat transfer-typical heat transfer situations- modes of heat transfer- mechanism of heat transfer- basic laws of heat transfer- thermal conductivity-effect of temperature on thermal conductivity- combined heat transfer mechanism-real life situations of combined heat transfer.

Differential equations of heat conduction-boundary conditions and initial conditions, one dimensional steady state situations – plane wall, cylinder, sphere -concept of thermal resistance, critical radius, conduction with heat generation- Two-dimensional steady state situations, transient conduction, Lumped capacitance model, concept of Heisler chart and Schmidt Plot-Conduction shape factor-Numerical methods of analysis-thermal analysis of rectangular fins.

Module 2

CONVECTION HEAT TRANSFER

Fundamentals, order of magnitude analysis of momentum and energy equations; hydrodynamic and thermal boundary Layers-Relation between fluid friction and heat transfer-Concepts of fluid mechanics, Differential equation of heat convection, Laminar flow heat transfer in circular pipe – constant heat flux and constant wall temperature, thermal entrance region, Turbulent flow heat transfer in circular pipe, pipes of other cross sections, Heat transfer in laminar flow and turbulent flow over a flat plate, Reynolds analogy, Flow across a cylinder and sphere- Natural convection- basics-free convection heat transfer on a vertical flat plate-empirical relations for free convection heat transfer.

Module 3

HEAT EXCHANGERS

Condensation heat transfer phenomena- the condensation Number-Boiling heat transfer Phenomena-Simplified relations for boiling heat transfer-Introduction to heat exchangers-types of heat exchangers-the overall heat transfer coefficient-Fouling factor-LMTD analysis of heat exchangers-effectiveness-NTU method-Analysis of variable properties-compact heat exchangers-heat exchanger design considerations.

Module 4**RADIATION HEAT TRANSFER**

Physical mechanism of radiation heat transfer-Radiation properties-; Black body radiation Planck's law, Wein's displacement law, Stefan Boltzmann law, Kirchoff's law; Gray body Radiation shape factors-heat exchange between non -black bodies-Infinite parallel planes-Radiation combined with conduction and convection.

Module 5**MASS TRANSFER**

Introduction to mass transfer- Molecular diffusion in fluids- Steady state molecular diffusion in fluids under stagnant and laminar flow conditions - Fick's law of diffusion-Types of solid diffusion- mass transfer coefficients in laminar and turbulent flows- Introduction to mass transfer coefficient- Equimolar counter-diffusion- Correlation for convective mass transfer coefficient- Correlation of mass transfer coefficients for single cylinder- Theories of mass transfer- Overall mass transfer coefficients.

Text Books

1. Sachdeva R.C., Fundamentals of Engineering Heat and Mass Transfer, New Age Science Limited, 2009
2. R.K.Rajput. Heat and mass transfer, S.Chand &Co., 2015
3. Nag P.K., Heat and Mass Transfer, McGrawHill, 2011
4. Kothandaraman C.P., Fundamentals of Heat and Mass Transfer, New Age International, New Delhi,2006

Data Book

Heat and Mass Transfer data book: C.P. Kothandaraman, S. Subramanya, New age International Publishers,2014

Reference Books

2. Holman J.P, "Heat transfer", Mc Graw-Hill, 10th. Ed.,2009.
3. Yunus A. Cengel, "Heat and Mass Transfer: Fundamentals and Applications" McGraw-Hill Higher Education; 6th edition,2019.
4. Frank P. Incropera and David P. Dewitt, Heat and Mass Transfer, John Wiley and sons,2011

COURSE PLAN

MODULE	TOPICS	HOURS ALLOTTED
1	Introduction to heat transfer- thermodynamics and heat transfer-typical heat transfer situations- modes of heat transfer- mechanism of heat transfer- basic laws of heat transfer- thermal conductivity-thermal conductivity-effect of temperature on thermal conductivity-combined heat transfer mechanism-real life situations of combined heat transfer.	2-0-0
	Differential equations of heat conduction-boundary conditions and initial conditions, one dimensional steady state situations – plane wall, cylinder, sphere -concept of thermal resistance, critical radius, conduction with heat generation- Two-dimensional steady state situations, transient conduction, Lumped capacitance model, concept of Heisler chart and Schmidt Plot-Conduction shape factor-Numerical methods of analysis- thermal analysis of rectangular fins.	6-4-0
2	Fundamentals, order of magnitude analysis of momentum and energy equations; hydrodynamic and thermal boundary Layers-Relation between fluid friction and heat transfer-Concepts of fluid mechanics, Differential equation of heat convection, Laminar flow heat transfer in circular pipe – constant heat flux and constant wall temperature, thermal entrance region, Turbulent flow heat transfer in circular pipe, pipes of other cross sections, Heat transfer in laminar flow and turbulent flow over a flat plate, Reynolds analogy, Flow across a cylinder and sphere- Natural convection- basics- free convection heat transfer on a vertical flat plate- empirical relations for free convection heat transfer.	6-4-0
3	Condensation heat transfer phenomena- the condensation Number-Boiling heat transfer Phenomena-Simplified relations for boiling heat transfer-Introduction to heat exchangers-types of heat exchangers-the overall heat transfer coefficient-Fouling factor-LMTD analysis of heat exchangers-effectiveness-NTU method-Analysis of variable properties- compact heat exchangers-heat exchanger design considerations.	5-2-0
4	Physical mechanism of radiation heat transfer-Radiation properties-; Black body radiation Planck's law, Wein's displacement law, Stefan Boltzmann law, Kirchoff's law; Gray body Radiation shape factors-heat exchange between non -black bodies-Infinite parallel planes-Radiation combined with conduction and convection.	5-2-0

5	Introduction to mass transfer- Molecular diffusion in fluids- Steady state molecular diffusion in fluids under stagnant and laminar flow conditions - Fick's law of diffusion-Types of solid diffusion- mass transfer coefficients in laminar and turbulent flows- Introduction to mass transfer coefficient- Equimolar counter-diffusion- Correlation for convective mass transfer coefficient- Correlation of mass transfer coefficients for single cylinder- Theories of mass transfer- Overall mass transfer coefficients	7-2-0
---	---	-------

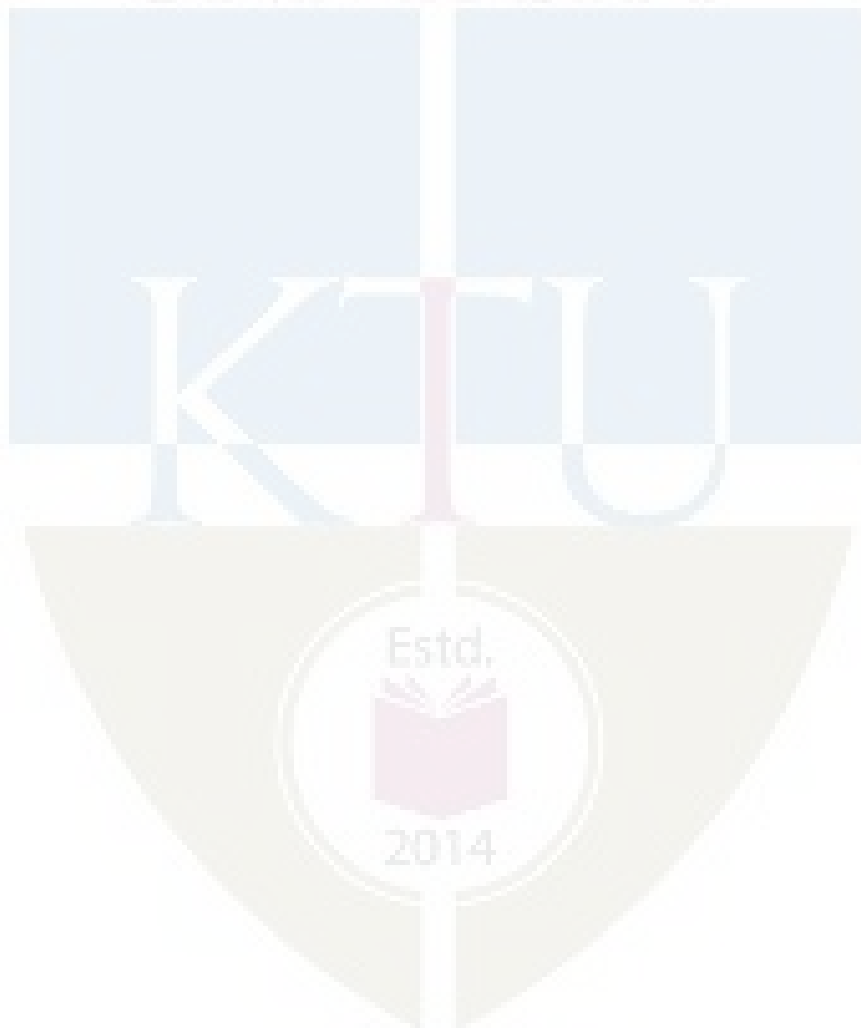

CODE MET304	COURSE NAME DYNAMICS AND DESIGN OF MACHINERY	CATEGORY	L	T	P	CREDIT
		PCC	3	1	0	4

Preamble: This course focuses on important topics of dynamics of machinery and design of machine elements. It covers the topics namely force of four bar mechanisms, design of flywheels, welded joints, riveted joints and spring. Design of machine elements due to impact, shock and fatigue loading are covered in the syllabus. Analysis of free and forced vibration of single degree of freedom systems and a brief introduction about free vibration of two degree of freedom systems is also included.

Prerequisite: EST100 Engineering Mechanics

Course Outcomes: After the completion of the course the student will be able to:

CO 1	Do engine force analysis and to draw turning moment diagrams
CO 2	Analyse free and forced vibrations of single degree of freedom systems
CO 3	Determine the natural frequencies of a two degree of freedom vibrating system and to calculate the stresses in a structural member due to combined loading
CO 4	Design machine elements subjected to fatigue loading and riveted joints
CO 5	Design welded joint and close coiled helical compression spring

Mapping of course outcomes with program outcomes

	PO 1	PO 2	PO 3	PO 4	PO 5	PO 6	PO 7	PO 8	PO 9	PO 10	PO 11	PO 12
CO 1	3	3	2									
CO 2	3	3	2									
CO 3	3	3	2									
CO 4	3	3	2									
CO 5	3	3	2									

Assessment Pattern

Bloom's Category	Continuous Assessment Tests		End Semester Examination
	1	2	
Remember	10	10	10
Understand	20	20	20
Apply	20	20	70
Analyse			
Evaluate			
Create			

Mark distribution

Total Marks	CIE	ESE	ESE Duration
150	50	100	3 hours

Continuous Internal Evaluation Pattern:

Attendance	: 10 marks
Continuous Assessment Test (2 numbers)	: 25 marks
Assignment/Quiz/Course project	: 15 marks

MECHANICAL ENGINEERING

End Semester Examination Pattern: There will be two parts; Part A and Part B. Part A contain 10 questions with 2 questions from each module, having 3 marks for each question. Students should answer all questions. Part B contains 2 questions from each module of which student should answer any one. Each question can have maximum 2 sub-divisions and carry 14 marks.

Course Level Assessment Questions

Course Outcome 1 (CO1):

1. Explain D' Alembert's principle.
2. Determine analytically the forces such as piston effort, force in the connecting rod and side thrust on the cylinder walls of a reciprocating engine.
3. Draw the turning moment diagram of IC engine.
4. Derive an expression for the coefficient of fluctuation of energy.
5. Derive an expression relating the stress in a flywheel and its linear speed.

Course Outcome 2 (CO2)

1. Explain the energy method and Newton's method to determine the natural frequencies of a single degree of freedom system.
2. Derive an expression for the logarithmic decrement.
3. Find the forced response of a damped single degree of freedom vibrating system subjected to a harmonic excitation.
4. Distinguish between motion transmissibility and force transmissibility.
5. What is whirling? Derive an expression for the critical speed of a shaft.

Course Outcome 3 (CO3):

1. Find the natural frequencies and mode shapes of a two degree freedom vibrating system.
2. What do you mean by eigenvalues and eigenvectors of a multi degree freedom vibrating system?
3. What are the steps in the design process?
4. Define stress concentration factor. How can we minimize it?

Course Outcome 4 (CO4):

1. Explain Goodman's criterion.

2. Explain Soderberg's criterion.
3. Define endurance limit and factor of safety.
4. Derive an expression for the impact stress due to a freely falling body.
5. Describe the modes of failure of a riveted joint.
6. What are the different efficiencies of a riveted joint?
7. Classify the riveted joints.

Course Outcome 5 (CO5):

1. What are the different types of welded joint?
2. Describe AWS welding symbols with neat sketches.
3. Determine the weld size of a joint subjected to axial, bending and twisting loads.
4. Derive an expression for the shear stress in the spring wire.
5. Derive an expression for the deflection of a helical compression spring.
6. Why concentric springs are required in certain applications?

MODEL QUESTION PAPER**APJ ABDUL KALAM TECHNOLOGICAL UNIVERSITY****VI SEMESTER BTECH DEGREE EXAMINATION****MET304 : DYNAMICS AND DESIGN OF MACHINERY**

Maximum: 100 Marks

Duration:3 hours

*Use of Machine Design Data Book is permitted.***PART A**

Answer all questions, each question carries 3 marks

1. Describe briefly the dynamic force analysis of a reciprocating engine.
2. Derive an expression for the coefficient of fluctuation of energy.
3. Derive an expression for logarithmic decrement.
4. Define whirling speed of a shaft.
5. Explain the mode shapes of a vibrating system.
6. What are the steps in the design process?
7. Define endurance limit. What are the factors affecting it?
8. What are the failure modes of a riveted joint?

9. Describe the AWS welding symbols.

10. Explain i) surge ii) resilience and iii) curvature effect of a spring. (10×3=30 Marks)

PART B

Answer one full question from each module

MODULE 1

11. a) Describe with a neat sketch the turning moment diagram for a four-stroke internal combustion engine (4 marks)

b) The turning moment of an engine is given by the equation: $2500 + 750 \sin 3\theta$ Nm where θ is the crank angle in radians. The mean speed of the engine is 300 rpm. The flywheel along with other rotating parts attached to the engine have a mass of 500 kg at a radius of gyration of 0.8 m. Determine i) the power developed by the engine and ii) the percentage of fluctuation of speed of the flywheel (10 marks)

12. a) State and explain D' Alembert's principle. (4 marks)

b) The ratio of connecting rod length to crank length of a vertical gasoline engine is 4. The engine bore and stroke are 8 cm and 10 cm respectively. The mass of the reciprocating parts is 1 kg. The gas pressure on the piston is 6 bar, when it has moved 40° from the inner dead centre during the power stroke. Determine the following:

- i. Net load on the piston
- ii. Net load on the gudgeon pin and the crank pin
- iii. Thrust on the cylinder walls
- iv. Thrust on the crank bearing

The engine runs at 2000 rpm. At what engine speed will the net load on the gudgeon pin be zero? (10 marks)

MODULE 2

13. a) A machine of mass 1000 kg is acted upon by an external force of 2450 N at a speed of 1500 rpm. To reduce the effect, vibration isolators made of rubber having a static deflection of 2 mm under the machine load and an estimated damping factor of 0.2 are used. Determine the following:

- i. Force transmitted to the foundation

ii. Amplitude of vibration of machine

iii. Phase lag between the transmitted force and the displacement of mass.

(9 marks)

b) Distinguish between motion transmissibility and displacement transmissibility. (5 marks)

14. a) A damped spring mass system has mass 3 kg, stiffness 100 N/m and damping coefficient 3 Ns/m. Determine the following:

i. Damping ratio

ii. Damped natural frequency

iii. Logarithmic decrement

iv. Ratio of two successive amplitudes

(8 marks)

b) Describe briefly Newton's method and energy method used for obtaining the natural frequencies. (6 marks)

MODULE 3

15. Find the natural frequencies and mode shapes of a two degree freedom system shown in figure. The masses are $m_1 = m_2 = 10$ kg and the stiffness values are $k_1 = k_2 = 2$ kN/mm.

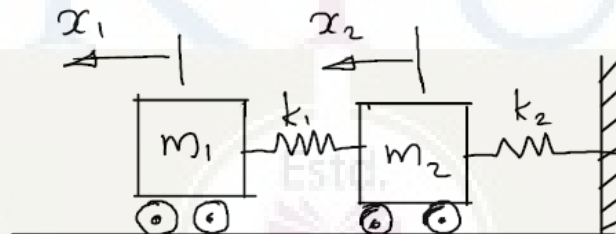

16. a) Define stress concentration factor. How can it be minimized?

(5 marks)

b) Calculate the stress at point A on the fixed end of a rod of length 80 mm and cross-sectional area 30 mm^2 shown in figure. (9 marks)

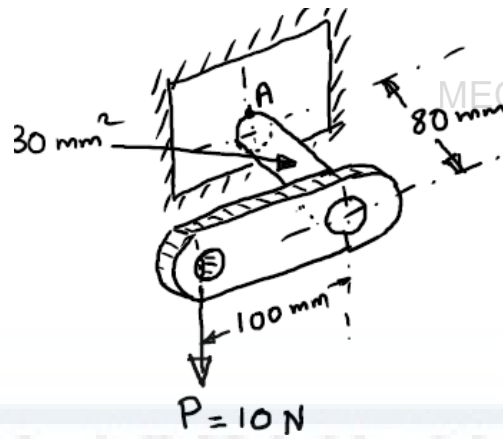

MODULE 4

17. a) Distinguish between Soderberg and Goodman criteria. (5 marks)

b) A round bar is subjected to the following variable loads. Torque varying from 2kNm to 5 kNm, bending moment varying from 10 kNm to 12 kNm. Calculate the size of the bar if it is made of C40 steel with yield stress of 324 MPa. Yield stress in shear is 50% of that in uniaxial loading. Adopt a factor of safety of 2.5 on yield stress for shear. (9 marks)

18. a) What are the advantages of riveted joint over welded joint? (4 marks)

b) Design a double riveted butt joint with equal widths of cover plates to join two plates of thickness 10 mm. The allowable stress for the material of the rivets and for the plates are as follows: For plate material in tension, $\sigma_t = 80$ MPa, for rivet material in compression, $\sigma_c = 120$ MPa, for rivet material in shear, $\tau = 60$ MPa (10 marks)

MODULE 5

19. a) Describe with neat sketches the different types of welded joints. (5 marks)

b) An eccentrically loaded bracket is welded to a support as shown in figure. The permissible shear stress for the weld material is 80 MPa. Determine the size of the weld. (9 marks)

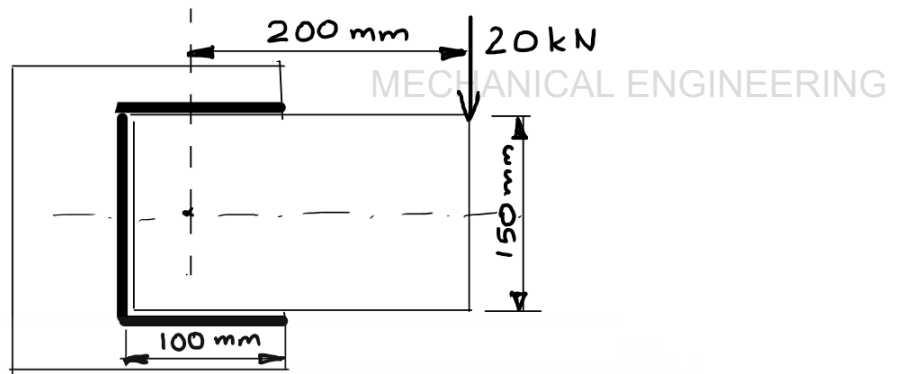

20. a) Derive an expression for the axial deflection of a close coiled helical spring.

(5 marks)

b) A bumper consisting of two helical springs of circular section, brings to rest a railway wagon of mass 1500 kg moving at 1.2 m/s. While doing so, the springs are compressed by 150 mm. The mean diameter of the coil is 6 times the wire diameter. The permissible shear stress is 400 MPa. Determine i) the maximum force on each spring ii) wire diameter of the spring, iii) mean diameter of the coils and iv) the number of active coils. Take $G=0.84 \times 10^6$ MPa.

(9 marks)

Syllabus

Module 1

Dynamic force analysis- D' Alembert's principle –four bar mechanism- engine force analysis (reciprocating engines)- piston side thrust-connecting rod force-piston effort- dynamic force analysis considering mass of the connecting rod-analytical method.

Flywheels-turning moment diagrams for four stroke internal combustion engine and multi cylinder engines-coefficient of fluctuation of speed-coefficient of fluctuation of energy-design of flywheels.

Module 2

Introduction- free vibration of single degree undamped systems- natural frequency-energy method- Newton's second law (free body diagram)-damped systems- logarithmic decrement.

Forced vibration-single degree of freedom systems-harmonic excitation-vibration isolation-transmissibility-whirling of shafts.

Module 3

Introduction to two degree of freedom systems- natural frequencies and mode shapes.

Introduction to design-definition, steps in the design process, materials and their properties-elastic and plastic behaviour of metals, ductile and brittle behaviour, shear, bending and torsional stresses, combined stresses, stress concentration factor.

Module 4

Shock and impact loads- fatigue loading- Gerber, Goodman and Soderberg criteria, endurance limit stress, factors affecting endurance limit, factor of safety.

Design of riveted joints- material for rivets, modes of failure, efficiency of joint, design of boiler and tank joints, structural joints.

Module 5

Design of welded joints-welding symbols, stresses in fillet and butt welds, Butt joint in tension, fillet weld in tension, fillet joint under torsion, fillet weld under bending, eccentrically loaded welds.

Springs- classification, spring materials, stresses and deflection of helical springs, axial loading, curvature effect, resilience, static and fatigue loading, surge in spring, critical frequency, concentric springs, end construction.

Text Books

1. Ballaney, P. L. Theory of machines and mechanisms. Khanna Publishers, 2010.
2. Rattan S S, Theory of Machines, Tata McGraw-Hill Education, 2005.
3. Bhandari V B, Design of Machine Elements, Tata McGraw-Hill Education, 2010.

Design Data Books (permitted for reference in the university examination)

1. Mahadevan, K., and K. Balaveera Reddy. Design Data Handbook; Mechanical Engineers in SI and Metric Units. CBS Publishers & Distributors, New Delhi, 2018.
2. NarayanaIyengar B.R & Lingaiah K, Machine Design Data Handbook, Tata McGraw Hill/Suma Publications, 1984
3. PSG Design Data, DPV Printers, Coimbatore, 2012

Reference Books

1. Charles E Wilson and J Peter Sadler, Kinematics and Dynamics of Machinery, Tata McGraw-Hill Education, 2008.
2. Amithabha Ghosh and Asok Kumar Malik, Theory of Mechanisms and Machines, East West Press, 2011
3. Robert L Norton, Design of Machinery, Tata Mc Graw-Hill, 2005
4. P C Sharma and D K Aggarwal, Machine Design, S K Kataria & Sons

Course Contents and Lecture Schedule

No	Topic	No. of Lectures
1		
1.1	Dynamic force analysis- D' Alembert's principle –Four bar mechanism-	3
1.2	Engine force analysis (reciprocating engines)- piston side thrust-connecting rod force-piston effort- dynamic force analysis considering mass of the connecting rod-analytical method.	4
1.3	Flywheels, turning moment diagrams-four stroke internal combustion engines and multi cylinder engines	3
1.4	Coefficient of fluctuation of speed-coefficient of fluctuation of energy-design of flywheels	2
2		
2.1	Introduction- free vibration of single degree undamped systems-natural frequency-energy method- Newton's second law (free body diagram)-damped systems- logarithmic decrement.	3
2.2	Forced vibration-single degree of freedom systems-harmonic excitation-vibration isolation-transmissibility-whirling of shafts.	3
3		
3.1	Introduction to two degree of freedom systems- natural frequencies and mode shapes.	3
3.2	Introduction to design-definition, steps in design process. materials and their properties- elastic and plastic behaviour of metals, ductile and brittle behaviour	3
3.3	Shear, bending and torsional stresses, combined stresses, stress concentration factor.	4
4		
4.1	Shock and Impact loads, fatigue loading- Gerber, Goodman and Soderberg criteria, endurance limit stress, factors affecting endurance limit, factor of safety.	2
4.2	Design of riveted joints- material for rivets, modes of failure, efficiency of joint, design of boiler and tank joints, structural joints.	3
5		
5.1	Design of welded joints-welding symbols, stresses in fillet and butt welds, butt joint in tension, fillet weld in tension,	3
5.2	Fillet joint under torsion, fillet weld under bending, eccentrically loaded welds.	2
5.3	Springs- classification, spring materials, stresses and deflection of	3

	helical springs, axial loading, curvature effect, resilience, static and fatigue loading	MECHANICAL ENGINEERING
5.4	Surge in spring, critical frequency, concentric springs, end construction.	3

API ABDUL KALAM
TECHNOLOGICAL
UNIVERSITY

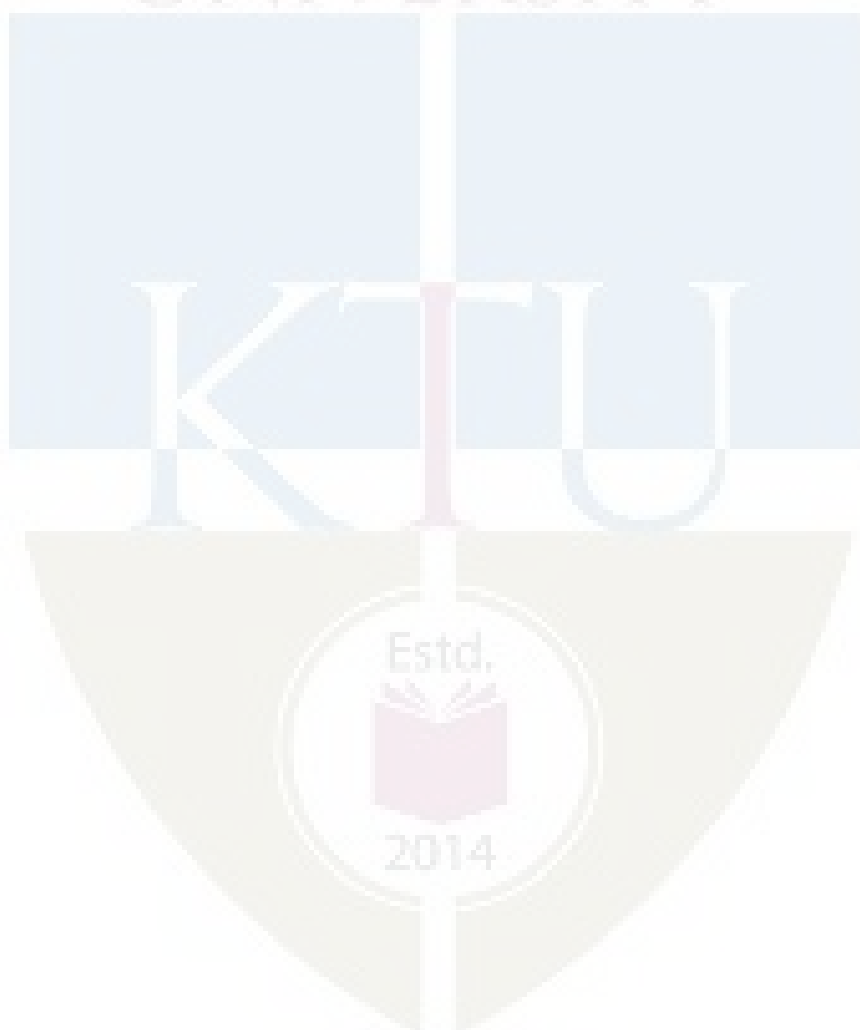

MET 306	ADVANCED MANUFACTURING ENGINEERING	CATEGORY	L	T	P	Credits
		PCC	3	1	0	4

Preamble:

1. Understand the capabilities, limitations of conventional manufacturing & machining process and what the need of advanced manufacturing processes is.
2. Understand, how to formulate tool path and program CNC machines.
3. Understand, how PLC operate and control automated equipment and systems.
4. Understand the need of atomic level surface roughness and machining process.
5. Understand the need of high velocity forming of metals.

Prerequisite: MET 205 Metallurgy and material science and MET204 Manufacturing Processes

Course Outcomes - At the end of the course students will be able to

CO 1	To be conversant with the advanced machining process and to appreciate the effect of process parameters on the surface integrity aspects during the advanced machining process.
CO 2	CNC programming, select appropriate tooling and fixtures.
CO 3	To categorize the various nontraditional material removal process based on energy sources and mechanism employed.
CO 4	Analyze the processes and evaluate the role of each process parameter during micro machining of various advanced material removal processes.
CO 5	Explain the processes used in additive manufacturing for a range of materials and applications.

Mapping of course outcomes with program outcomes (Minimum requirements)

	PO 1	PO 2	PO 3	PO 4	PO 5	PO 6	PO 7	PO 8	PO 9	PO 10	PO 11	PO 12
CO 1	3	-	-	-	2	-	-	-	-	-	-	2
CO 2	2	-	2	-	3	-	-	-	-	-	-	-
CO 3	2	-	-	-	2	-	-	-	-	-	-	2
CO 4	2	3	-	-	2	-	-	-	-	-	-	-
CO 5	2	-	-	3	2	-	-	-	-	-	2	-

Assessment Pattern

Bloom's taxonomy	Continuous Assessment Tests		End Semester Examination (Marks)
	Test I (Marks)	Test II (Marks)	
Remember	25	25	25
Understand	15	15	15
Apply	30	25	30
Analyze	10	10	10
Evaluate	10	15	10
Create	10	10	10

Mark distribution			
Total Marks	CIE marks	ESE marks	ESE duration
150	50	100	3 Hours
Continuous Internal Evaluation (CIE) Pattern:			
Attendance		10 marks	
Regular class work/tutorials/assignments/self-learning (Minimum 3numbers)		15 marks	
Continuous Assessment Test(Minimum 2numbers)		25 marks	
<p>End semester pattern: -There will be two parts; Part A and Part B. Part A contain 10 questions with 2 questions from each module, having 3 marks for each question. Students should answer all questions. Part B contains 2 questions from each module of which student should answer anyone. Each question can have maximum 2 sub-divisions and carry 14 marks.</p>			

COURSE LEVEL ASSESSMENT QUESTIONS

Course Outcome 1 (CO1): - To be conversant with the advanced machining process and to appreciate the effect of process parameters on the surface integrity aspects during the advanced machining process.

1. How carbonyls are useful in powder metallurgy?
2. A simple integrator in which p is a constant is performed with a DDA integrator. Calculate the output Δz at the first 8 iterations. The DDA contains 3-bit register which are initially set $p=5$ and $q=0$. If each iteration is executed in 1 ms, draw the accumulated output Δz versus time.

3. What are the process parameters affecting the performance of USM
4. Draw and explain the effect of high speed on stress strain relationship of mild steel and copper

Course Outcome 2 (CO2): CNC programming, select appropriate tooling and fixtures.

1. Draw relay ladder diagram for the following sequential operations. Start button pressed, table motor started, package moves to the position of the limit switch and stops. Auxiliary features required are emergency stop, red light to indicate stop condition and green light to indicate package moving condition. Draw input and output connection diagrams also.
2. Draw a PLC ladder logic diagram to get the reciprocating motion of a punching machine using following sequential operations. One of the two motors operates when power is supplied. Motor drives the punch to one side. When it completes the required movement in one direction, a limit switch detects the position of the punch. First motor is get deactivated. Second motor starts and moves the punch to the opposite direction. When it completes required movement in opposite direction, a second limit switch detects the position of the punch. Second motor is get deactivated and first motor is started again and the process continues so as to get a continuous reciprocating motion. Also draw the input and output diagrams.
3. A DDA contains 8 bit registers. The value of its p register is constant and $P=150$ and the clock frequency is 10240pps. Calculate the output frequency of DDA
4. Describe with sketch the working and construction of recirculating ball screw used in CNC machine tools.
5. Explain linear and circular interpolations used in turning. Draw a neat sketch of circular interpolation

Course Outcome 3 (CO3): To categorize the various nontraditional material removal process based on energy sources and mechanism employed.

1. How the amplitude and frequency of vibration effects on material removal rate in Ultra Sonic Machining
2. What are the functions of electrolyte in ECM? What are the properties to be considered while selecting electrolytes in ECM?
3. What are the process parameters affecting the performance of USM

4. Which are the factors affecting its MRR in IBM process.
5. Describe the mechanism of material removal in Ion beam machining

Course Outcome 4 (CO4): Analyze the processes and evaluate the role of each process parameter during micro machining of various advanced material removal processes.

1. What is magneto rheological lapping? What are its advantages over conventional lapping?
2. Ablation of metals with Ultra short laser pulses.
3. Explain different types of elastic body waves
4. Draw and explain the effect of high speed on stress strain relationship of mild steel and copper
5. Explain with a neat schematic the fundamental principle of material removal in an abrasive jet machining process. Plot the trend for the Material Removal Rate with Nozzle Tip Distance (NTD) and explain why it rises, plateaus and falls with increasing NTD.
6. What is meant by ductile regime machine?

Course Outcome 5 (CO5): Explain the processes used in additive manufacturing for a range of materials and applications.

1. What are the two materials that are most commonly used for doing rapid prototyping of parts
2. What are the major process parameters involved in LIGA process?
3. A new car is designed, incorporating new technology, suggest how rapid prototyping could be applied for the development of the product. what are the steps followed? Discuss the factors considered.



MODEL QUESTION PAPER
SIXTH SEMESTER MECHANICAL ENGINEERING
MET 306 - ADVANCED MANUFACTURING ENGINEERING

Maximum Marks: 100

Duration: 3 Hours

Part – A

Answer all questions, each question carries 3 marks

1. Explain the different stages of sintering process in Powder metallurgy
2. Differentiate the impregnation and infiltration process in Powder metallurgy
3. What are the different word address formats used in part programming?
4. Mention the purpose of miscellaneous functions in part programming. Write any 2 M –codes with their applications
5. Describe the mechanism of material removal in Ion beam machining
6. What are the functions and desirable properties of dielectric fluid in EDM?
7. Explain the two Techniques in Explosive forming process
8. Differentiate P wave and S wave in High Velocity Forming
9. Write a note on Elastic Emission Machining
10. Explain the LIGA and its application, what is the aspect ratio in LIGA.

PART -B

Answer one full question from each module.

MODULE – 1

11. a) Explain the need and comparison between traditional and non-traditional manufacturing processes. (7 marks).
12. Explain Merchant's theory with neat sketches. (14 marks).

MODULE – 2

Write a Manual Part Program for the given figure (14 marks).

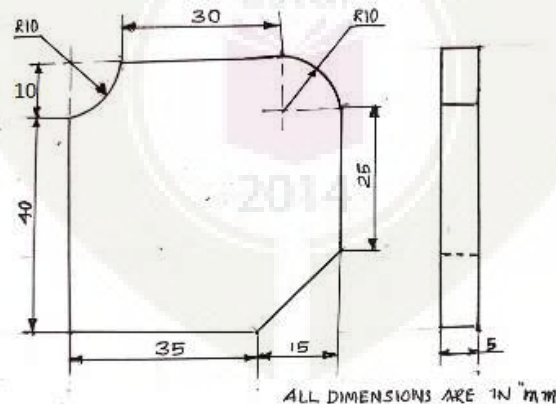

13. What is meant by interpolation in NC systems? Explain different types of interpolations. (14marks)

MODULE – 3

14. a) What are the parameters influencing the MRR in USM process (7 marks).
b) How LBM differs from and EBM (7 marks).
15. Explain IBM with neat sketch; applications and vividly the process parameters influencing on it (14marks).
16. **MODULE – 4**
a) Compare high velocity forming with conventional forming process (7 marks).
b) What are stress waves? Write the equation for finding the velocity of shear wave (7 marks).
17. Explain Electro Magnetic Forming and show that it can be applied to internal, external and surface forming operations. (14 marks).
- MODULE – 5**
18. a.Explain the material removal mechanism in Diamond turn machining process (7 marks).
b. With a neat sketch explain Diamond turn machining process. (7 marks).
19. a. With a neat sketch explain Selective Laser Sintering.(7 marks).
20. b.Describe the Laminated Object Manufacturing Process (7 marks).

SYLLABUS

Module I

Powder Metallurgy- Powder Production- Powder characteristics- Mixing – Compaction: - techniques- sintering- Theory metal cutting - Orthogonal and oblique cutting- chip formation- Merchant's theory-Friction force - cutting tool materials -Thermal aspects of machining -Tool wear and wear mechanisms - Economics of machining- Machinability- Cutting fluids.

Module II

Programmable Logic Controllers (PLC) – CNC: systems - contouring systems: principle of operation -DDA integrator: -Principle of operation, exponential deceleration –liner, circular and complete interpolator - NC part programming - Computer aided part programming - machining centers, feedback devices.

Module III

Non Traditional machining processes: - EDM, USM, ECM, LBM, EBM, PAM, IBM, AJM, AWJM.

Module IV

High velocity forming of metals - Sheet metal forming - explosive forming - Electro hydraulic forming - Electro Magnetic Forming.

Module V

Micromachining: Diamond turn mechanism, Advanced finishing processes: - Abrasive Flow Machining, Magnetic Abrasive Finishing. - Magnetorheological Finishing, Magnetorheological Abrasive Flow Finishing, Magnetic Float Polishing, Elastic Emission Machining. - Material addition processes: - stereo-lithography, selective laser sintering, fused deposition modeling, laminated object manufacturing, laser engineered net-shaping, laser welding, LIGA process.

Text Books

1. YoramKoren, Computer control of manufacturing systems, TMH
2. Jain V.K., Introduction to Micromachining, Narosa publishers.
3. Davies K and Austin E.R, Developments in high speed metal forming, the machinery publishing Co, 1970, SBN -853332053

Reference

1. ASTME, High velocity forming of metals, PHI, 1968.
2. Ibrahim Zeid, R Sivasubrahmanian CAD/CAM: Theory & Practice Tata McGraw Hill Education Private Limited, Delhi.
3. .P.Groover, E.M. Zimmers, Jr.”CAD/CAM”; Computer Aided Design and Manufacturing, Prentice Hall of India, 1987
4. PetruzellaFrank.D. - Programmable logic controllers
5. Jain V.K., Advanced Machining Processes
6. Armarego and Brown, The Machining of Metals, Prentice – Hall.
7. Paul. H. Black, Theory of Metal Cutting, McGraw Hill.
8. ASM hand book Volume 16, Machining, ASM international, 1989
9. Lal G.K., Introduction to Machining Science, New Age Publishers.

COURSE CONTENT AND LECTURE SCHEDULES.

Module	TOPIC	No.of hours	Course outcomes
1.1	Introduction: Need and comparison between traditional, non-traditional and micro & nano machining process.	2	CO1
	Powder Metallurgy: Need of P/M - Powder Production methods:- Atomization, electrolysis, Reduction of oxides, Carbonyls (Process parameters, characteristics of powder produced in each method).		
1.2	Powder characteristics: properties of fine powder, size, size distribution, shape, compressibility, purity etc.	2	CO1
	Mixing – Compaction:- techniques, pressure distribution, HIP & CIP(fundamentals to be explained in the class, self-learning topic , discretion of faculty)..		
1.3	Mechanism of sintering, driving force for pore shirking, solid and liquid phase sintering - Impregnation and Infiltration Advantages, disadvantages and specific applications of P/M.	1	
1.4	Theory metal cutting in turning: Tool nomenclature, attributes, surface roughness obtainable - Orthogonal and oblique cutting - Mechanism of metal removal - Mechanism of chip formation –chip breakers – Merchant’s theory.	3	CO1
1.5	Friction force laws in metal cutting - development of cutting tool materials (fundamentals to be explained in the class, self-learning topic, discretion of faculty).	1	CO1
1.6	Thermal aspects of machining -Tool wear and wear mechanisms - Economics of machining, Machinability, Cutting fluids(fundamentals to be explained in the class, self-learning topic, discretion of faculty).	1	CO1
2.1	Programmable Logic Controllers (PLC):need – relays - logic ladder program –timers, simple problems only.	1	CO1 CO2
2.2	Point to point, straight cut and contouring positioning - incremental and absolute systems – open loop and closed loop systems - control loops in contouring systems: principle of operation -DDA integrator:-Principle of operation, exponential deceleration –liner, circular and complete interpolator.	3	
2.3	NC part programming: part programming fundamentals - manual programming –NC coordinate systems and axes – tape format – sequence number, preparatory functions, dimension words, speed word, feed word, tool word, miscellaneous functions –	2	CO1 CO2
2.4	Computer aided part programming:- CNC languages – APT language structure.	3	CO1

	Programming exercises: simple problems on turning and drilling etc - (At least one programming exercise must be included in the end semester University examination). - machining centers, feedback devices (fundamentals to be explained in the class, self-learning topic, discretion of faculty).		CO2
3.1	Non Traditional machining processes:- Electric Discharge Machining (EDM):- Mechanism of metal removal, dielectric fluid, spark generation, recast layer and attributes of process characteristics on MRR, accuracy, HAZ etc, Wire EDM, applications and accessories.	2	CO1 CO3
	Ultrasonic Machining (USM):-mechanics of cutting, effects of parameters on amplitude, frequency of vibration, grain diameter, slurry, tool material attributes and hardness of work material, applications.	2	CO1 CO3
3.2	Electro chemical machining (ECM):- Mechanism of metal removal attributes of process characteristics on MRR, accuracy, surface roughness etc, application and limitations.	1	CO1 CO3
3.3	Laser Beam Machining (LBM), Electron Beam Machining (EBM), Plasma arc Machining (PAM), Ion beam Machining(IBM) - Mechanism of metal removal, attributes of process characteristics on MRR, accuracy etc and structure of HAZ compared with conventional process; application, comparative study of advantages and limitations of each process.	3	CO1 CO3
3.4	Abrasive Jet Machining (AJM), Abrasive Water Jet Machining (AWJM) - Working principle, Mechanism of metal removal, Influence of process parameters, Applications, Advantages & disadvantages.	1	CO1 CO3
4.1	High velocity forming of metals:-effects of high speeds on the stress strain relationship steel, aluminum, Copper – comparison of conventional and high velocity forming methods- deformation velocity, material behavior, stain distribution.	2	CO1 CO3
4.2	Stress waves and deformation in solids – types of elastic body waves- relation at free boundaries- relative particle velocity.	2	CO1 CO3
4.3	Sheet metal forming: - explosive forming:-process variable,properties of explosively formed parts, etc.	2	CO1 CO3
4.4	Electro hydraulic forming: - theory, process variables, etc, comparison with explosive forming -Electro Magnetic Forming.	2	CO1 CO3
5.1	Micromachining: Diamond turn mechanism, material removal mechanism, applications.- Advanced finishing processes: - Abrasive Flow Machining, Magnetic Abrasive Finishing.	3	CO1 CO4
5.2	Magnetorheological Finishing, Magnetorheological Abrasive Flow Finishing, Magnetic Float Polishing, Elastic Emission Machining.	3	CO4
5.3	Material addition process:- stereo-lithography, selective laser sintering, fused deposition modeling, laminated object manufacturing, laser engineered net-shaping, laser welding, LIGA process.	3	CO5

CODE MET 312	COURSE NAME NON DESTRUCTIVE TESTING	CATEGORY	L	T	P	CREDIT
		PEC	2	1	0	3

Preamble:

Nondestructive Testing (NDT) plays an extremely important role in quality control, flaw detection and structural health monitoring covering a wide range of industries. There are varieties of NDT techniques in use. This course will first cover the fundamental science behind the commonly used NDT methods to build the basic understanding on the underlying principles. It will then go on to cover the process details of each of these NDT methods.

Prerequisite: NIL

Course Outcomes: After the completion of the course the student will be able to

CO 1	Have a basic knowledge of surface NDT which enables to carry out various inspections in accordance with the established procedures.
CO 2	The students will be able to differentiate various defect types and select the appropriate NDT methods for the specimen.
CO 3	Calibrate the instrument and evaluate the component for imperfections.
CO 4	Have a basic knowledge of ultrasonic testing which enables them to perform inspection of samples.
CO 5	Have a complete theoretical and practical understanding of the radiographic testing, interpretation and evaluation.

Mapping of course outcomes with program outcomes

	PO 1	PO 2	PO 3	PO 4	PO 5	PO 6	PO 7	PO 8	PO 9	PO 10	PO 11	PO 12
CO 1	3	3	2									1
CO 2	3	3	2									1
CO 3	3	3	1									2
CO 4	3	3	2									2
CO 5	3	3	1									1

Assessment Pattern

Bloom's Category	Continuous Assessment Tests		End Semester Examination
	1	2	
Remember	25	25	25
Understand	25	25	25
Apply	30	30	30
Analyse	10	10	10
Evaluate	10	10	10
Create			

Mark distribution

Total Marks	CIE	ESE	ESE Duration
150	50	100	3 hours

Continuous Internal Evaluation Pattern:

Attendance : 10 marks

Continuous Assessment Test (2 numbers) : 25 marks

Assignment/Quiz/Course project : 15 marks

End Semester Examination Pattern: There will be two parts; Part A and Part B. Part A contain 10 questions with 2 questions from each module, having 3 marks for each question. Students should answer all questions. Part B contains 2 questions from each module of which student should answer any one. Each question can have maximum 2 sub-divisions and carry 14 marks.

Course Level Assessment Questions**Course Outcome 1 (CO1):**

1. Explain why NDT methods were initially developed
2. Describe the uses of NDT
3. Define the functionality of Destructive method

Course Outcome 2 (CO2)

1. Name the various nondestructive test methods
2. Recognize the NDT method abbreviations
3. Briefly explain each NDT method

Course Outcome 3(CO3):

1. Explain the discontinuities inherent in various manufacturing processes
2. Define the causes, prevention, and repair of those welding discontinuities
3. Explain the discontinuities inherent in various welding processes

Course Outcome 4 (CO4):

1. Explain basic principle of Radiographic examination.
2. Discuss principle of radiographic testing and give its application and limitation

3. Explain the principle, application and disadvantages of Radiographic Testing.

Course Outcome 5 (CO5):

1. Describe the various types of RT equipment
2. Describe the basic principles of gamma and X-ray generation
3. Name the three means of protection to help reduce exposure to radiation

MODEL QUESTION PAPER

SIXTH SEMESTER MECHANICAL ENGINEERING

NON DESTRUCTIVE TESTING - MET 312

Max. Marks : 100

Duration : 3 Hours

Part – A

Answer all questions, each question carries 3 marks

1. Define Non-destructive testing?
2. Explain the basic principle of Visual testing?
3. Explain the sequence of operation of Liquid penetrant testing?
4. Explain the basic principle of Liquid penetrant testing?
5. How are the materials classified based on their interaction with a magnetic field?
6. Explain the Hysteresis Loop and Magnetic Properties of a material?
7. Compare X-rays and Gamma rays?
8. What is Snell's Law and its significance in Ultrasonic Testing?
9. Define the terms (a) Radiation Energy, (b) Intensity
10. What are the physical aspects of E.C.T?

PART -B

Answer one full question from each module.

MODULE – 1

11. a) With the help of suitable examples, differentiate between destructive and nondestructive testing techniques. **(8 Mark)**

b) With the help of a neat diagram, explain computer enhanced visual inspection system. **(6 Mark)**

OR

12. a) Explain visual inspection process. Also explain about the different types of optical aids used in the process. **(8 Mark)**

b) List the applications and Limitations of Visual inspection technique in NDT **(6 Mark)**

MODULE – 2

13. a) How are the penetrants classified based on **(8 Mark)**

- a. Physical properties
- b. Removal techniques
- c. Strength of indication

b) What are the methods used to remove excess penetrants during LPI **(6 Mark)**

OR

14. a) Explain the working principle of liquid penetrant inspection (LPI). With neat sketches explain the various steps involved in performing LPI. **(8 Mark)**

b) Explain different types of developers and how it is being applied **(6 Mark)**

MODULE – 3

15. a) With the help of neat sketches explain about any four types of magnetization techniques used in magnetic particle inspection (MPI). **(8 Mark)**

b) What are the differences between dry and wet continuous MPI? **(6 Mark)**

OR

16. a) Differentiate between direct and indirect method of magnetization. Write the advantages and disadvantages of both methods. **(8 Mark)**

b) What is continuous testing and residual technique of MPI **(6 Mark)**

MODULE – 4

17. a) With the help of neat figures, differentiate between through transmission technique and pulse echo testing techniques used in ultrasonic testing. **(8 mark)**

b) What are the different types of probes used in ultrasonic testing? **(6 mark)**

OR

18. a) What are the different wave forms used in ultrasonic testing? **(8 Mark)**

b) With neat sketches explain the following: **(6 mark)**

- i) A-Scan
- ii) B-Scan
- iii) C-Scan

MODULE – 5

19. a) With neat sketches explain about the different inspection techniques in radiography testing (RT). **(8 Mark)**
 b) Explain about various steps involved in film processing in RT. **(6 mark)**

OR

20. a) Explain the following terms associated with ECT: **(8 Mark)**
 i) Lift off effect ii) Edge effect iii) End effect
 b) Explain about eddy current testing (ECT) technique in detail. **(6 mark)**

SYLLABUS

Module 1

NDT Versus Mechanical testing-Overview of the Non Destructive Testing Methods for the detection of manufacturing defects as well as material characterisation-Relative merits and limitations-various physical characteristics of materials and their applications in NDT.

Visual Inspection: Fundamentals of Visual Testing – vision, lighting, material attributes, environmental factors, visual perception, direct and indirect methods – mirrors, magnifiers, Boroscopes and fibro scopes– light sources and special lighting–calibration- computer enhanced system

Module 2

Liquid Penetrant Inspection: Principles – types and properties of liquid penetrants – developers – advantages and limitations of various methods - Preparation of test materials – Application of penetrants to parts, removal of excess penetrants, post cleaning – Control and measurement of penetrant process variables –selection of penetrant method – solvent removable, water washable, post emulsifiable – Units and lighting for penetrant testing – calibration- Interpretation and evaluation of test results - dye penetrant process applicable codes and standards.

Module 3

Magnetic Particle Inspection (MPI): Important terminologies related to magnetic properties of material, principle-magnetizing technique, procedure, and equipment, fluorescent magnetic particle testing method, sensitivity-application and limitation-Methods of magnetization, magnetization techniques such as head shot technique, cold shot technique- central conductor testing, and magnetization using products using yokes-direct and indirect method of magnetization - continuous testing of MPI, residual technique of MPI- checking devices in MPI, Interpretation of MPI, indications, advantage and limitation of MPI.

Module 4

Ultrasonic Testing: Basic principles of sound propagation, types of sound waves, Principle of UT-methods of UT, their advantages and limitations-Piezoelectric Material, Various types of transducers/probe-Calibration methods, contact testing and immersion testing, normal beam and straight beam testing, angle beam testing, dual crystal probe, ultrasonic testing techniques resonance testing, through transmission technique, pulse echo testing technique, instruments

used UT, accessories such as transducers, types, frequencies, and sizes commonly used. Reference of standard blocks-technique for normal beam inspection-flaw characterization technique, defects in welded products by UT-Thickness determination by ultrasonic method;- Study of A, B and C scan presentations-Time of Flight Diffraction (TOFD).

Module 5

Radiography: X-rays and Gamma rays, Properties of X-rays relevant to NDE - Absorption of rays - scattering. Characteristics of films- graininess, Density, Speed, Contrast. Characteristic curves. Inspection techniques like SWSI, DWSI, DWDI, panoramic exposure, real time radiography, films used in industrial radiography

Eddy Current Testing: Generation of eddy currents – effect of change of impedance on instrumentation – properties of eddy currents – eddy current sensing elements, probes, type of coil arrangement – absolute, differential, lift off, operation, applications, advantages, limitations Field factor and lift of effect, edge effect, end effect, impedance plane diagram in brief, depth of penetration of ECT, relation between frequency and depth of penetration in ECT.

Text Books

1. Baldev Raj, Practical Non – Destructive Testing, Narosa Publishing House, 1997
2. J.Prasad and C. G. K. Nair, Non-Destructive Test and Evaluation of Materials, Tata McGraw-Hill Education, 2nd edition (2011).
3. B.Raj, T. Jayakumar and M. Thavasimuthu, Practical Non Destructive Testing, Alpha Science International Limited, 3 rd edition (2007).
4. T. Rangachari, J. Prasad and B.N.S. Murthy, Treatise on Non-destructive Testing and Evaluation, Navbharath Enterprises, Vol.3, (1983).
5. Ed. Peter.J. Shull, Non-destructive Evaluation: Theory, Techniques, and Applications, Marcel Dekker (2002). 2.

Reference Books

1. C. Hellier, Handbook of Non-Destructive Evaluation, McGraw-Hill Professional, 1st edition (2001).
2. J. Thomas Schmidt, K. Skeie and P. MacIntire, ASNT Non Destructive Testing Handbook: Magnetic Particle Testing, American Society for Non-destructive Testing, American Society for Metals, 2nd edition (1989).
3. Krautkramer, Josef and Hebert Krautkramer, Ultrasonic Testing of Materials, Springer Verlag, 1990

Course Contents and Lecture Schedule

No	Topic	No. of Lectures
MODULE 1		
1.1	NDT Versus Mechanical testing-Overview of the Non Destructive Testing Methods for the detection of manufacturing defects as well as material characterisation	2
1.2	Relative merits and limitations-various physical characteristics of materials and their applications in NDT	1
1.3	Fundamentals of Visual Testing – vision, lighting, material attributes, environmental factors, visual perception, direct and indirect methods	1
1.4	Mirrors, magnifiers, Boroscopes and fibro scopes	1
1.5	light sources and special lighting, calibration- computer enhanced system	2
MODULE 2		
2.1	Liquid Penetrant Inspection: Principles – types and properties of liquid penetrants – developers	1
2.2	Advantages and limitations of various methods - Preparation of test materials	1
2.3	Application of penetrants to parts, removal of excess penetrants, post cleaning	1
2.4	Control and measurement of penetrant process variables –selection of penetrant method	1
2.5	solvent removable, water washable, post emulsifiable – Units and lighting for penetrant testing	1
2.6	calibration- Interpretation and evaluation of test results - dye penetrant process applicable codes and standards	2
MODULE 3		
3.1	Magnetic Particle Inspection (MPI): Important terminologies related to magnetic properties of material	1
3.2	Principle-magnetizing technique, procedure, and equipment, fluorescent magnetic particle testing method, Sensitivity	1
3.3	Methods of magnetization, magnetization techniques such as head shot technique, cold shot technique- central conductor testing,	1
3.4	magnetization using products using yokes-direct and indirect method of magnetization - continuous testing of MPI	1
3.5	residual technique of MPI- checking devices in MPI	1
3.6	Indications, advantage and limitation of MPI.	1
MODULE 4		
4.1	Ultrasonic Testing: Basic principles of sound propagation, types of	

	sound waves, Principle of UT-methods of UT	1
4.2	Piezoelectric Material, Various types of transducers/probe Calibration methods, contact testing and immersion testing, normal beam and straight beam testing,	1
4.3	Angle beam testing, dual crystal probe, ultrasonic testing techniques resonance testing, through transmission technique, pulse echo testing technique	1
4.4	Accessories such as transducers, types, frequencies, and sizes commonly used. Reference of standard blocks	1
4.5	Technique for normal beam inspection Thickness determination by ultrasonic method	1
4.6	Study of A, B and C scan presentations, Instruments used UT	1
4.7	Time of Flight Diffraction (TOFD).	1
MODULE 5		
5.1	Radiography: X-rays and Gamma rays, Properties of X-rays relevant to NDE - Absorption of rays - scattering	1
5.2	Characteristics of films- graininess, Density, Speed, Contrast. Characteristic curves. Inspection techniques like SWSI, DWSI, DWDI	1
5.3	Panoramic exposure, real time radiography, films used in industrial radiography	1
5.4	Eddy Current Testing: Generation of eddy currents – effect of change of impedance on instrumentation – properties of eddy currents	1
5.5	Eddy current sensing elements, probes, type of coil arrangement – absolute, differential, lift off, operation, applications, advantages, limitations	1
5.6	Field factor and lift of effect, edge effect, end effect, impedance plane diagram in brief, depth of penetration of ECT	1
5.7	Relation between frequency and depth of penetration in ECT.	1

CODE MET322	COURSE NAME COMPUTATIONAL FLUID DYNAMICS	CATEGORY	L	T	P	CREDIT
		PEC	2	1	0	3

Preamble:

This course introduces the students to finite difference methods as a means of solving different types of differential equations that arise in fluid dynamics and heat transfer. Fundamentals of numerical analysis, ordinary differential equations and partial differential equations related to fluid mechanics and heat transfer will be reviewed. Error control and stability considerations are discussed. A class of methods used in computational fluid dynamics for numerically solving the Navier-Stokes equations normally for incompressible flows will be covered in this course.

Prerequisite: MET 203 Mechanics of Fluids

Course Outcomes: After the completion of the course the student will be able to

CO 1	Understanding the governing equations dominating fluid flow and heat transfer and their mathematical and physical nature.
CO 2	Understand finite difference method to fluid flow problems and the level of errors associated with these methods.
CO 3	Understand and apply finite volume method to fluid flow and heat transfer problems.
CO 4	Understand and apply finite volume method to diffusion and convection problems and various interpolation schemes.
CO 5	Understand various methods in numerically solving Navier Stokes equation for incompressible flows.
CO 6	Understand various graphical techniques to present post processed results.

Mapping of course outcomes with program outcomes

	PO 1	PO 2	PO 3	PO 4	PO 5	PO 6	PO 7	PO 8	PO 9	PO 10	PO 11	PO 12
CO 1	3	2										
CO 2	3	2	1									
CO 3	3	3	1									
CO 4	3	3	1									
CO 5	3	2	1									
CO 6	3	2	1									

Assessment Pattern

Bloom's Category	Continuous Assessment Tests		End Semester Examination
	1	2	
Remember	10	10	10
Understand	20	20	20
Apply	20	20	70
Analyse			
Evaluate			
Create			

Mark distribution

Total Marks	CIE	ESE	ESE Duration
150	50	100	3 hours

Continuous Internal Evaluation Pattern:

Attendance	: 10 marks
Continuous Assessment Test (2 numbers)	: 25 marks
Assignment/Quiz/Course project	: 15 marks

End Semester Examination Pattern: There will be two parts; Part A and Part B. Part A contain 10 questions with 2 questions from each module, having 3 marks for each question. Students should answer all questions. Part B contains 2 questions from each module of which student should answer any one. Each question can have maximum 2 sub-divisions and carry 14 marks.

Course Level Assessment Questions

Course Outcome 1 (CO1):

- 1 Derive Navier Stokes equation in conservative form
- 2 Write a note on elliptical, parabolic and hyperbolic PDEs as applicable to CFD
- 3 Explain the applications of CFD in various industries.

Course Outcome 2 (CO2)

- 1 Explain finite difference method in brief. Give the justification for the choice for the finite difference method
- 2 Write a note on central and upwind difference schemes for one dimensional steady convection-diffusion equation
- 3 Obtain a 5-point centre-difference scheme for $\frac{\partial^2 \phi}{\partial x^2}$ at grid-point i using $\phi_{i-2}, \phi_{i-1}, \phi_i, \phi_{i+1}, \phi_{i+2}$ and find its truncation error.

Course Outcome 3(CO3):

1. Consider a heat conduction problem governed by $\frac{\partial T}{\partial t} = \alpha \frac{\partial^2 T}{\partial x^2}$. Develop a finite difference representation for this equation by the control-volume approach. Do not assume that the grid is uniform.
2. Explain the features of TDMA method
3. Write a note on explicit and implicit approaches and stability criteria.

Course Outcome 4 (CO4):

1. A property ϕ is transported by means of convection and diffusion through the one-dimensional domain. The governing equation is $[Dw \frac{\partial \phi}{\partial x} - (De - \phi Fe) \frac{\partial \phi}{\partial x} + (Fe - \phi Fw)] \frac{\partial \phi}{\partial x} = P - Dw \frac{\partial \phi}{\partial x} - W \frac{\partial \phi}{\partial x} - (De - \phi Fe) \frac{\partial \phi}{\partial x}$; the boundary conditions are $\phi_0 = 1$ at $x = 0$ and $\phi L = 0$ at $x = L$. Using QUICK scheme for convection and diffusion, calculate the distribution of ϕ as a function of x for (i) Case 1: $u = 0.1$ m/s, (ii) Case 2: $u = 2.5$ m/s

2. Explain Crank-Nicolson implicit scheme used for solving the parabolic partial differential equations
3. A property ϕ is transported by means of convection and diffusion through the one-dimensional domain. The governing equation is $[D_w \frac{\partial \phi}{\partial x} - \Gamma \frac{\partial^2 \phi}{\partial x^2}] = P - D_w \frac{\partial \phi}{\partial x} - \Gamma \frac{\partial^2 \phi}{\partial x^2}$; the boundary conditions are $\phi_0 = 1$ at $x = 0$ and $\phi_L = 0$ at $x = L$. Using upwind differencing scheme for convection and diffusion, calculate the distribution of ϕ as a function of x for (i) Case 1: $u = 0.1$ m/s, (ii) Case 2: $u = 2.5$ m/s with the coarse five-point grid

Course Outcome 5 (CO5):

1. Derive the expression for vorticity at the wall in terms of stream function. The expression should contain the interior points only. One could use no-slip velocity boundary condition at the wall in deriving the expression.
2. Write vorticity stream function equations
3. Describe the philosophy of Pressure Correction technique. Explain how boundary conditions are specified consistent with the philosophy of Pressure Correction method

Course Outcome 6 (CO6):

1. Explain SIMPLE Algorithm
2. Derive Pressure Correction formula considering two dimensional flows and explain step by step procedure for SIMPLE algorithm
3. Write a note on computer graphics techniques used to present post processed CFD results

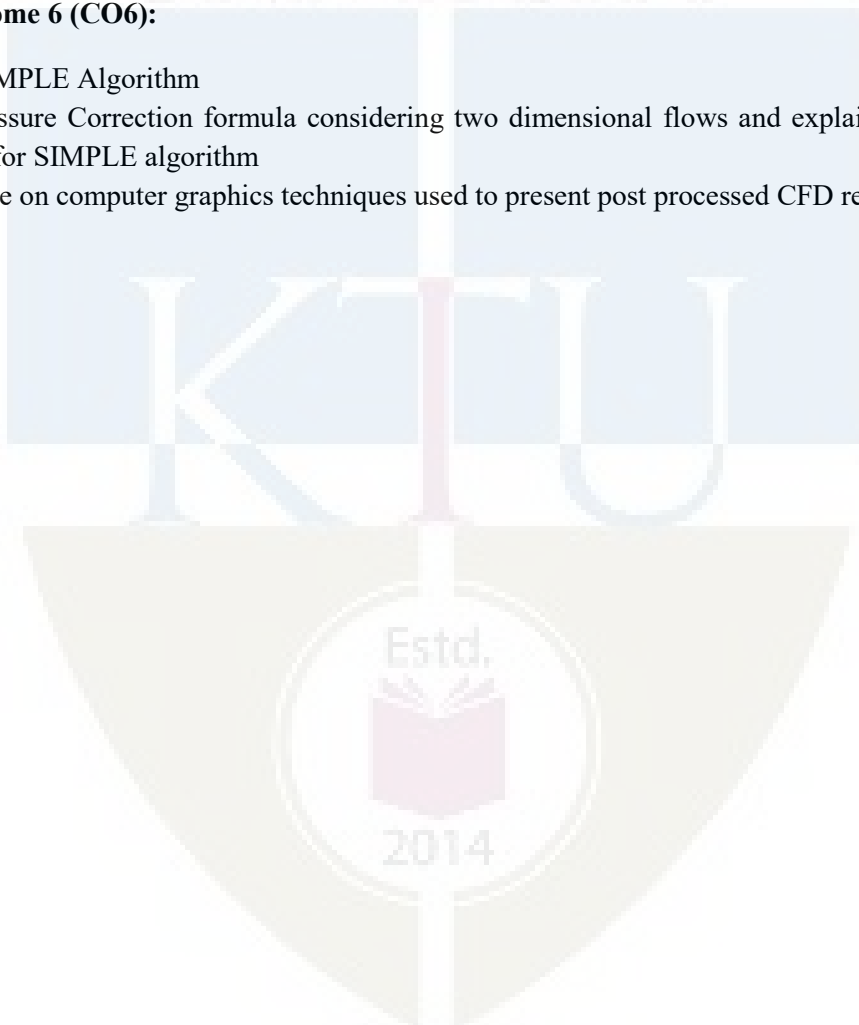

APJ ABDUL KALAM TECHNOLOGICAL UNIVERSITY
SIXTH SEMESTER B.TECH DEGREE EXAMINATION

Course Code: MET 322

Course Name: COMPUTATIONAL FLUID DYNAMICS

Max. Marks: 100

Duration: 3 Hours

PART A

ANSWER ALL QUESTIONS, EACH QUESTION CARRIES 3 MARKS)

1. Explain the merits and demerits of numerical approaches over theoretical and experimental approaches.
2. Show that the second-order wave equation is a hyperbolic partial differential equation.
3. Using Taylor series, derive a first order and a second order difference equation for $\frac{\partial u}{\partial y}$.
4. Explain the relaxation techniques used in numerical schemes.
5. Explain Dirichlet, Neumann, and Robins type boundary conditions.
6. Derive the difference equation for steady one-dimensional heat conduction problem.
7. Discuss a situation where upwind differencing scheme is preferred over central differencing scheme.
8. Suggest a numerical difference scheme for which numerical false diffusion is desirable and justify your suggestion.
9. Explain any three graphical methods to present CFD results.
10. Discuss the importance of staggered grid in numerically solving incompressible viscous flow problems. (10 X 3 = 30 Marks)

PART B

Module 1

(ANSWER ONE FULL QUESTION FROM EACH MODULE)

11. Explain the significance of parabolic, hyperbolic and elliptic partial differential equations in a numerical perspective. (14 Marks)
12. Write down the Navier-Stokes equation in vector form by clearly mentioning the solution vector, flux vector and source vector. Convert the Navier-Stokes equations into non-dimensional form. (14 Marks)

Module 2

13. Consider the viscous flow of air over a flat plate. At a given station in the flow direction, the variation of the flow velocity, u , in the direction perpendicular to the plate (the y direction) is given by the expression $u = 21582 \left(1 - e^{\left(\frac{-y}{L} \right)} \right)$ where $L =$ characteristic length = 0.05 m. The unit of u is m/s. The viscosity coefficient $\mu = 1.81 \times 10^{-5}$ kg/(m.s). Using the equation for u , find the values of u at discrete grid points equally spaced in the y direction with $\Delta y = 0.002m$. With the values obtained at discrete grid points located at $y=0, 0.002$ m, 0.004 m, and 0.006 m, calculate the shear stress at the wall τ_w (a) using a first order difference equation and (b) second order difference equation. Compare these calculated finite difference results with the exact value of τ_w which can be found by making use of the expression for u . (14 Marks)

14. The equation for deflection of a beam is given by $\frac{d^2y}{dx^2} - e^{x^2} = 0$ and deflection at $x = 0$ and $x = 1$ are given by $y(0) = 0$ and $y(1) = 0$. Use the difference equations to find the approximate deflection at $x = 0.25, 0.5$, and 0.75 . (14 Marks)

Module 3

15. Consider the problem of source-free heat conduction in an insulated rod of 0.5 m length whose ends are maintained at constant temperatures of 100°C and 500°C respectively. The one-dimensional problem is governed by $\frac{d}{dx} \left(\frac{k \cdot dT}{dx} \right) = 0$. Calculate the steady state temperature distribution in the rod using finite volume method. Thermal conductivity k equals 1000 W/m.K, cross-sectional area A is $10 \times 10^{-3} \text{m}^2$. Use cell centered grid points. (14 Marks)
16. Two plastic sheets, each 5 mm thick, are to be bonded together with a thin layer of adhesive that fuses at 140 °C. For this purpose, they are pressed between two surfaces at 250 °C. Using finite volume method, determine the time for which the two sheets should be pressed together, if the initial temperature of the sheets (and the adhesive) is 30 °C. For plastic sheets, thermal conductivity $k=0.25$ W/m-K, specific heat $C=2000$ J/kg-K and density, $\rho=1300$ kg/m³. (14 Marks)

Module 4

17. A property ϕ is transported by means of convection and diffusion through the one-dimensional domain $0 \leq X \leq L$. The governing equation is $\frac{d}{dx} \rho u \phi = \frac{d}{dx} \left(\Gamma \left(\frac{d\phi}{dx} \right) \right)$; the boundary conditions are $\phi_0 = 1$ at $x = 0$ and $\phi_L = 0$ at $x = L$. Using five equally spaced cells and the central differencing scheme for convection and diffusion, calculate the distribution of ϕ as a function of x for $u = 0.1$ m/s. Compare the results with the analytical solution $(\phi - \phi_0) \left(\phi_L - \phi_0 \right)^{\frac{\rho u x}{\Gamma}} \left(\left(\frac{\rho u x}{\Gamma} \right) - 1 \right)$. (14 Marks)
18. Make a comparison of central differencing scheme and upwind differencing scheme. Explain the influence of numerical false diffusion on these two schemes. (14 Marks)

Module 5

19. Derive the stream function- vorticity formulation for the Navier-Stokes equation by clearly stating the assumptions. (14 Marks)
20. Explain the SIMPLE algorithm. Make a discussion of the pressure correction equation and the boundary conditions for the pressure correction equation. (14 Marks)

MODULE : 1

Governing equations of fluid mechanics and heat transfer; fundamental equations – continuity equation, momentum equation and energy equation; non-dimensional form of equations; boundary layer equations for steady incompressible flows. Physical and mathematical classifications of partial differential equations. Comparison of experimental, theoretical and numerical approaches; applications of CFD.

MODULE : 2

Discretization-converting derivatives to their finite difference forms-Taylor's series approach, polynomial fitting approach; forward, backward and central differencing Schemes. Discretization error, truncation error, round off error. Consistency and numerical stability, iterative convergence, condition for convergence, rate of convergence; under and over relaxations, termination of iteration.

MODULE : 3

Finite volume method for Steady one-dimensional conduction problems; handling of boundary conditions; two-dimensional steady state conduction problems; point-by-point and line-by-line method of solution; dealing with Dirichlet, Neumann, and Robin type boundary conditions; tri-diagonal matrix algorithm; transient heat conduction problems - explicit, implicit, Crank-Nicholson and ADI schemes.

MODULE : 4

Finite volume method for diffusion and convection-diffusion problems; steady one-dimensional convection and diffusion; upwind, hybrid, power-law and QUICK schemes; false diffusion.

MODULE : 5

Computation of the flow field using stream function-vorticity formulation. Two dimensional incompressible viscous flow. Staggered grid. Pressure correction methods. Solution algorithm for pressure-velocity coupling in steady flows-SIMPLE algorithm. Boundary conditions for the pressure correction method. Computer graphics techniques to present CFD results.

Text Books

1. S V Patankar, Numerical Heat Transfer and Fluid Flow, McGraw-Hill
2. John D Anderson Jr, Computational Fluid Dynamics, McGraw-Hill Book Company

Reference Books

1. K Muralidhar, T Sundararakjan, Computational Fluid Flow and Heat transfer, Narosa, 2nd Edition, 2011
2. Tapan K Senguptha, Computational Fluid Dynamics, University Press, 2005

Course Contents and Lecture Schedule

No	Topic	No. of Lectures
Module I		
1	Fundamental equations fluid mechanics and heat transfer	1
2	Continuity equation, momentum equation and energy equation;	2
3	Non-dimensional form of equations	1
4	Boundary layer equations for steady incompressible flows.	1
5	Physical and mathematical classifications of partial differential equations.	1
6	Comparison of experimental, theoretical and numerical approaches; applications of CFD.	1
Module II		
1	Discretization-converting derivatives to their finite difference forms-Taylor's series approach and polynomial fitting approach	1
2	Forward, backward and central differencing Schemes.	1
3	Discretization error, truncation error, round off error	1
4	Consistency and numerical stability	1
5	Iterative convergence, condition for convergence, rate of convergence	1
6	Under and over relaxations, termination of iteration.	1
Module III		
1	Finite volume method for steady one-dimensional conduction problems	1
2	handling of boundary conditions;	1
3	two-dimensional steady state conduction problems; point-by-point and line-by-line method of solution;	1
4	dealing with Dirichlet, Neumann, and Robins type boundary conditions;	1
5	tri-diagonal matrix algorithm;	1
6	transient heat conduction problems -explicit, implicit, Crank-Nicholson schemes	2
7	ADI scheme	1
Module IV		
1	Finite volume method for diffusion and convection-diffusion problems;	1
2	Upwind scheme for steady one-dimensional convection and diffusion	1
3	Hybrid scheme and power-law scheme	2
4	QUICK scheme	1
5	Numerical false diffusion	1
Module V		
1	Computation of the flow field using stream function-vorticity formulation.	2
2	Two dimensional incompressible viscous flow.	1
3	Staggered grid. Pressure correction methods.	1
4	Solution algorithm for pressure-velocity coupling in steady flows-SIMPLE algorithm.	2
5	Boundary conditions for the pressure correction method.	1
6	Computer graphics techniques to present CFD results.	1

CODE MET332	COURSE NAME ADVANCED MECHANICS OF SOLIDS	CATEGORY	L	T	P	CREDIT
		PEC	2	1	0	3

Preamble: This elective course is designed to guide the student to move to the next level of what was included in the third semester course on Strength of Materials (MET 201 MECHANICS OF SOLIDS). Some of the materials which are usually preliminary for a paper like this, have got discussed in that prerequisite, and hence not repeated here. Application of stress and strain analysis in two and three dimensions to solve engineering problems is what is aimed at. The course is supposed to serve necessary background material for future courses on Finite Element Method, and advanced courses on Elasticity.

Prerequisite: MET 201 MECHANICS OF SOLIDS

Course Outcomes: After the completion of the course the student will be able to

CO 1	Formulate the field equations of Elasticity.
CO 2	Model some engineering problems as two-dimensional, for easy solutions involving a Stress Function.
CO 3	Develop solutions for axi-symmetric problems for applications in thick pressure vessels and in rotating circular discs.
CO 4	Extend the basic ideas related to theory of elastic flexure, for skewed loading and for beams which are curved.
CO 5	Apply solution methods for torsion in components with non-circular cross sections and thin walled structures.

Mapping of course outcomes with program outcomes

	PO 1	PO 2	PO 3	PO 4	PO 5	PO 6	PO 7	PO 8	PO 9	PO 10	PO 11	PO 12
CO 1	3	2	1									
CO 2	2	3	1									
CO 3	2	3	1									
CO 4	3	2	1									
CO 5	2	3	1									

Assessment Pattern

Bloom's Category	Continuous Assessment Tests		End Semester Examination
	1	2	
Remember	10	10	10
Understand	20	20	20
Apply	20	20	70
Analyse			
Evaluate			
Create			

Mark distribution

Total Marks	CIE	ESE	ESE Duration
150	50	100	3 hours

Continuous Internal Evaluation Pattern:

Attendance : 10 marks

Continuous Assessment Test (2 numbers) : 25 marks

Assignment/Quiz/Course project : 15 marks

End Semester Examination Pattern: There will be two parts; Part A and Part B. Part A contain 10 questions with 2 questions from each module, having 3 marks for each question. Students should answer all questions. Part B contains 2 questions from each module of which student should answer any one. Each question can have maximum 2 sub-divisions and carry 14 marks.

Course Level Assessment Questions**Course Outcome 1 (CO1):**

1. Formulate all Field equations of elasticity.
2. Establishing the compatibility equations.
3. Realizing the differences between the formulation strategies of solutions in solid mechanics.
4. Formal proof for the uniqueness of the intended solutions.

Course Outcome 2 (CO2)

1. Realization that a vast majority of problems reduces to two-dimensional (either plane-stress or plane strain).
2. Formulating the Airy's stress function for two-dimensional problems.
3. Extending the Airy's method to solve practical problems like that encountered in contact analysis.

Course Outcome 3(CO3):

1. Formulation of equation for stresses and deflections in axi-symmetric problems.
2. Extend the axi-symmetric solutions for engineering applications in structures which are pressurised from the inside, as well as outside.
3. Extend the axi-symmetric theory to solve stresses and deformations in spinning discs.

Course Outcome 4 (CO4):

1. Extend the basic elastic flexure formula to cases when the load is skewed.
2. Develop the necessary framework to solve stresses in curved beams.

Course Outcome 5 (CO5):

1. Applying the St. Venant's torsion theory for non-circular cross sections
2. Applying Prandtl's Stress Function to solve Torsion and its applicability in terms of Membrane Analogy.
3. Stress analysis in thin walled closed sections.

Model Question paper

APJ ABDUL KALAM TECHNOLOGICAL UNIVERSITY

SIXTH SEMESTER B.TECH DEGREE EXAMINATION

Course Code : MET332 Course Name : ADVANCED MECHANICS OF SOLIDS

Max. Marks : 100

Duration : 3 Hours

PART – A (ANSWER ALL QUESTIONS, EACH QUESTION CARRIES 3 MARKS)

1. Discuss the different types of boundary conditions encountered in the solution of elasticity problems.
2. What are Compatibility equations? Why are they essential in solving elasticity problems?
3. Express stress-strain relations in Matrix format for Plane-Stress and Plane-Strain problems.
4. Elucidate an example for the application of superposition in solving contact stress problems.
5. Derive expressions for circumferential and axial stresses in a thin cylindrical pipe of diameter 'd', thickness 't' and subjected to internal pressure 'P'.
6. Derive expressions for Circumferential Strain and Radial Strain for a two-dimensional thick cylinder (axi-symmetric) problem.
7. Discuss the significance of Shear-Centre in solving Bending of beams.
8. State all relevant assumptions in solving bending stress problems in curved beams using Winkler- Bach theory.
9. Elucidate the difference in approach between St. Venant's theory and Prandtl's theory in the solution of torsion problems.

10. How are torsion problems solved experimentally, making use of Prandtl's membrane analogy?

PART – B (ANSWER ONE FULL QUESTION FROM EACH MODULE)

MODULE – 1

11. (a) For a two-dimensional stress problem described using cylindrical coordinates, derive the equations of equilibrium in terms of (r, θ) . (10 Marks)

(b) For the following plane strain distribution, verify whether the compatibility condition is satisfied:

$$\epsilon_{xx} = 3x^2y, \epsilon_{yy} = 4y^2x + 10^{-2}, \gamma_{xy} = 2xy + 2x^3 \quad (4 \text{ Marks})$$

12. (a) Given the fact that the strain energy density is positive-definite, show that the field equations of elasticity yields a Unique solution for a given system of forces and boundary conditions. (8 marks)

(b) Derive the equations of equilibrium in rectangular Cartesian coordinates. (6 Marks)

MODULE – 2

13. Figure shows a cantilever (of depth $2c$) loaded by u.d.l. of magnitude 'q'. If the Airy's stress function for this problem is $\phi = A [y^5 - 2c^2y^3 - 10x^2y^3 + 30c^2x^2y - 20c^3x^2]$, (a) show that it is an acceptable stress function for Airy's method and (b) evaluate 'A' for this problem. (14 Marks)

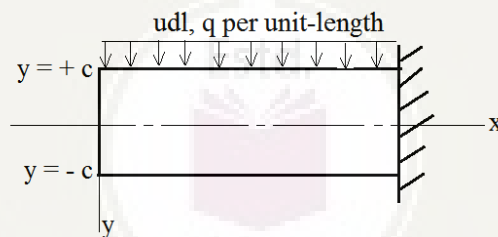

14. If the Airy' stress function (ϕ) in polar coordinates for solving contact stresses due to line-load on a straight boundary is $\phi(r, \theta) = - (W/L \pi) r \theta \sin \theta$ (where 'W/L' is the normal load per unit length), (a) show that it is an acceptable stress function for Airy's method (b) evaluate stresses for this two-dimensional stress-field (c) Show that the reactions offered by the resulting stress balances the externally applied load.

(14 Marks)

MODULE – 3

15. (a) Assuming plane stress, the stresses in a hollow thick cylinder of radius 'a' and external radius 'b' subjected to uniform (compressive) pressure of magnitude P_a and P_b inside and outside respectively is of the form

$$\sigma_r = \frac{E}{1-\nu^2} \left[C_1(1+\nu) - C_2(1-\nu) \frac{1}{r^2} \right]$$

$$\sigma_\theta = \frac{E}{1-\nu^2} \left[C_1(1+\nu) + C_2(1-\nu) \frac{1}{r^2} \right]$$

where 'r' is the radius at any point. Evaluate the constants C_1 and C_2 .

(b) Based on the above, develop expressions for (i) an internally pressurised thick cylinder and (ii) thick cylinder under external pressure. Plot the variation of stresses across thickness for both cases. (14 Marks)

16. A rotating disc ($N=3500$ rpm) with a hole has an inner radius of 10 cm and outer radius of 35 cm. If the Poisson's ratio of the material is 0.3 and density is 8050 kg/m^3 , (i) calculate and plot the distribution of radial and circumferential stresses across the radius (ii) Find the maximum values of radial and circumferential stresses. (14 Marks)

MODULE - 4

17. Find the maximum stress in the section A-B, if the cross-section is a square of sides 3 cm x 3 cm, for an applied load of $P=3000\text{N}$. Also, plot the variation of stresses across section, indicating the location of centroid and the neutral-axis. (14 Marks)

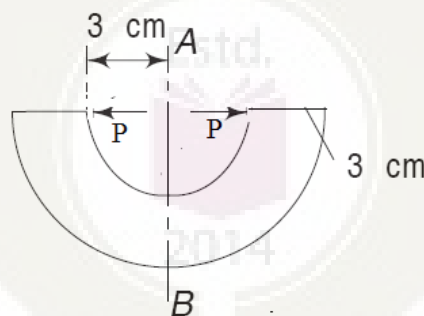

18. A rectangular beam with a 10 cm \times 15 cm section is used as a simply supported beam of 3 m span. It carries a uniformly distributed load of 1470 N per meter. The load acts in a plane making 30° with the vertical. Calculate the maximum flexural stress at all corners of the cross-section at the mid-span and also locate the neutral axis for the same section. (14 Marks)

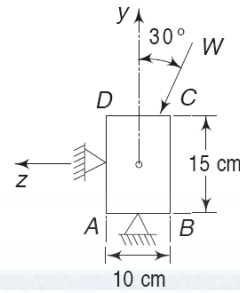
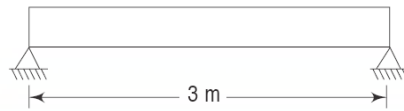

APJ ABDUL KALAM
TECHNOLOGICAL
UNIVERSITY

MODULE - 5

19. Show that the stress function $m \left[\frac{x^2}{a^2} + \frac{y^2}{b^2} - 1 \right]$ is a valid Prandtl's stress function for solving torsion problem on an elliptical cross section of major axis 2a and minor axis 2b. Derive expressions for (i) Angle of twist per unit length (ii) Torsional rigidity (iii) Stresses (iv) Max. Stress. (14 Marks)

20. The cross-section of an aerofoil- model in a small wind-tunnel tested for the torque induced due to circulation around it, is idealized as shown in figure. If the shear strength of the material used for the model is 40 MPa and if the shear-modulus, 'G' is 26 GPa, find the limiting-torque for which it can be tested. How much would it deform (angular deflection) under this condition. Use 3mm wall thickness all around. (14 Marks)

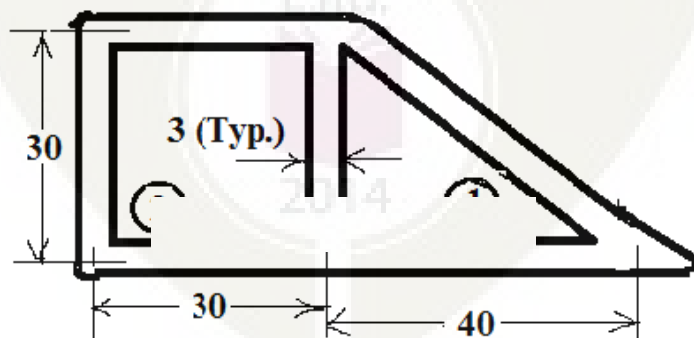

All dimensions in mm

Syllabus

Module 1

Field equations of Elasticity: Equations of equilibrium in rectangular and cylindrical polar coordinates – strain-displacement-relations - constitutive equations. Boundary value problems: Different boundary conditions- Examples for Displacement Formulation/ Force Formulation. Compatibility equations - Uniqueness of solution and superposition- St. Venant's principle.

Module 2

Two dimensional problems in elasticity: Stress-strain relations for Plane stress and Plane strain cases. Airy's Stress Functions for solution of stresses: problems in Rectangular as well as in Polar coordinates- contact stresses due to concentrated normal force (line load) on a straight boundary using Airy's stress function, and its extension to solve for stresses due to uniform normal pressure.

Module 3

Axisymmetric problems: Thin cylinders pressurized from inside, and thick cylinders pressurized from inside and outside - Rotating disks.

Module 4

Unsymmetrical bending of straight beams possessing two axes of symmetry-shear center-Winkler Bach theory for Bending of curved beams (with rectangular cross-section).

Module 5

Torsion of non-circular bars: St. Venant's and Prandtl's methods- solutions for elliptical cross-section. Membrane analogy –torsion of thin walled closed sections .

Text Books

1. Nambudiripad K. B. M, "Advanced Mechanics of Solids- A Gentle Introduction", Narosa Publishing House, First Edition, 2018.
2. Srinath L. S., "Advanced Mechanics of Solids", Tata McGraw Hill Publishing Company, Third Edition, 2009.
3. Jose S., "Advanced Mechanics of Materials", Pentagon Educational Services, Second Edition, 2017.
4. Anil Lal S., "Advanced Mechanics of Solids", Siva Publications and Distributors, First Edition, 2017.

Reference Books

1. Ragab A. R. and Bayoumi S. E., “Engineering Solid Mechanics, Fundamentals and Applications”, CRC Press, First Edition, 2018.
2. Timoshenko S. P., and Goodier J. N., “Theory of Elasticity”, McGraw Hill (India), Private Limited, NewDelhi, Third Edition, 2010.
3. Sadd M. H., “Elasticity: Theory, Applications and Numerics”, Academic Press, Indian reprint, 2nd edition, 2012.

Course Contents and Lecture Schedule

No	Topic	No. of Lectures
1	Module-1: Field Equations	7
1.1	Review of Stress-tensor, strain-displacement relations and strain tensor. Derivation of Equilibrium equations in rectangular and polar coordinates.	2 Hours
1.2	Generalised Hooke’s law for linearly elastic, homogeneous isotropic solids	1 Hour
1.3	Boundary conditions in Elasticity problems with examples, Displacement Formulation/ Force Formulation Uniqueness of Solutions, Method of Super position	2 Hours
1.4	Compatibility equations, St. Venants Principle	2 Hours
2	Module-2: Two-dimensional problems	7
2.1	Stress-strain relations for Plane –stress and plane strain conditions	1 Hour
2.2	Formulation of the Airys stress function in Rectangular and Polar Coordinates	2 Hours
2.3	Illustrative examples for solutions using Airy’s stress function	2 Hours
2.4	Contact stresses due to concentrated normal force (line load) on a straight boundary using Airy’s stress function, and its extension to solve for stresses due to uniform normal pressure.	2 Hours
3	Module-3: Axi-symmetric Problems	7
3.1	Stresses in Thin Cylindrical shells and numerical problems.	1 Hour
3.2	Axisymmetric problems: Basic Formulation	1 Hour
3.3	Application to thick shells	1 Hour
3.4	Numerical problems related to thick shells	1 Hour
3.5	Formulation of rotating disks	1 Hour
3.6	Numerical problems related to rotating disks	2 Hours
4	Module-4: Special Topics in Bending	7
4.1	Unsymmetrical bending of straight beams possessing two axes of	1 Hour

	symmetry.	
4.2	Numerical problems related to Unsymmetrical bending of straight beams	2 Hours
4.3	Shear Centre	1 Hour
4.4	Winkler Bach theory for Bending of curved beams	1 Hour
4.5	Numerical problems related to Unsymmetrical bending of straight beams	2 Hours
5	Module-5: Torsion of Non-Circular Sections	7
5.1	St. Venant's torsion theory	2 Hours
5.2	Prandtl's torsion theory	1 Hour
5.3	Membrane Analogy	1 Hour
5.4	Torsion of thin walled cross sections	1 Hour
5.5	Numerical problems on torsion of thin walled sections	2 Hours

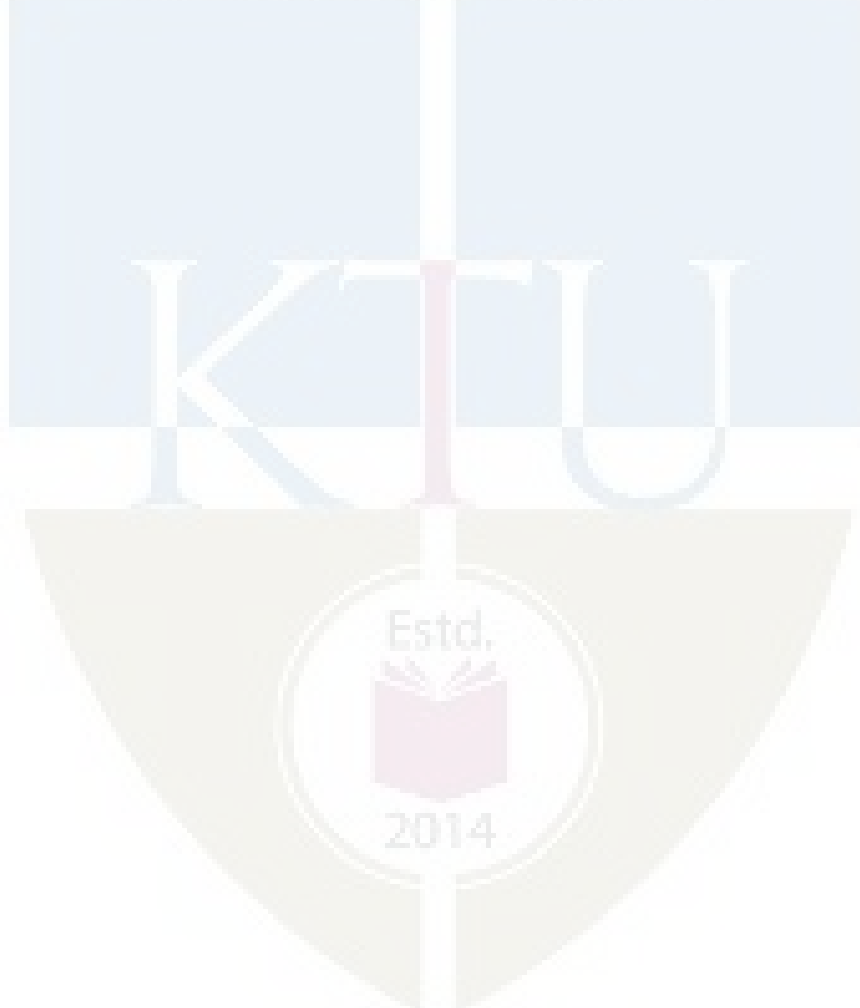

CODE	COURSENAME	CATEGORY	L-T-P	CREDITS
MET 342	IC ENGINE COMBUSTION AND POLLUTION	PEC	2-1-0	3

Preamble :

This course provides basic concepts on fuel-air mixing, theory of combustion in IC engines. To provide knowledge on emission control technologies of IC engines.

Prerequisite : Thermal Engineering

Course Outcomes :

After completion of the course the student will be able to

CO1	Explain the basic concepts of fuel air mixing
CO2	Understand the combustion process of SI engine
CO3	Understand the combustion process of CI engine
CO4	Explore various alternate fuels in IC engine
CO5	Describe emission control technologies of IC engine

Mapping of course outcomes with program outcomes

	PO1	PO2	PO3	PO4	PO5	PO6	PO7	PO8	PO9	PO10	PO11	PO12
CO1	3	2										
CO2	3	1										
CO3	3	1										
CO4	3	2				1	1					
CO5	3	1				1	1					

Assessment Pattern

Bloom Category	Continuous Assessment Tests		End Semester Examination
	1	2	
Remember	10	10	10
Understand	20	20	20
Apply	20	20	70
Analyse			
Evaluate			
Create			

Total Marks	CIE	ESE	ESE Duration
150	50	100	3 hours

Mark distribution:**Continuous Internal Evaluation Pattern:**

Attendance : 10 marks

Continuous Assessment Test (2 numbers) : 25 marks

Assignment/Quiz/Course project : 15 marks

End semester pattern:

There will be two parts; Part A and Part B. Part A contain 10 questions with 2 questions from each module, having 3 marks for each question. Students should answer all questions. Part B contains 2 questions from each module of which student should answer any one. Each question can have maximum 2 sub-divisions and carry 14 marks.

Course Level Assessment Questions:**Course Outcome 1 (CO1):**

1. Explain the different air-fuel ratios required for different operating conditions of a gasoline engine?
2. What are the different air fuel mixtures on which an engine can be operated?
3. Explain the following; 1.Richmixture, 2.Stoichiometric mixture3. Lean mixture.

Course Outcome 2 (CO2):

1. What are the major factors to be considered for the design of SI engine combustion chamber?
2. Define the terms flame development and flame propagation in engines
3. Using the pressure crank angle diagram (P- θ) explain the different stages of desirable combustion in a SI engine .Also explain how abnormal combustion takes place (P- θ) diagram?

Course Outcome 3 (CO3):

1. Briefly explain the thermodynamic analysis of CI engine combustion process.Explain clearly assumption made.
2. Explain the various factors that influence spray penetration in CI engine.
3. What is the effect of EGR in emissions from CI engine?

Course Outcome 4 (CO4):

1. Discuss the salient properties of hydrogen as a fuel.
2. What is the modification to be made in CI engine running on biodiesel? Explain in detail about the use of the biodiesel as fuel in CI engine and various merits and demerits of it use?
3. Explain the fuel characteristics of alcohols,CNG,LPG & hydrogen?

Course Outcome 5 (CO5):

1. List the major pollutants from SI engines. How can we measure and control each of them
2. What are the effects of pollutants from CI engines on environment and human beings? How can these be controlled to a certain extent.
3. Explain soot and particulate traps.

MODEL QUESTION PAPER
APJ ABDUL KALAM TECHNOLOGICAL UNIVERSITY
VI SEMESTER B.TECH DEGREE EXAMINATION
MET342: IC ENGINE COMBUSTION AND POLLUTION

Maximum: 100 Marks**Duration: 3 hours****PART A**

Answer all questions, each question carries 3 marks

1. What are the different air fuel mixtures on which an engine can be operated?
2. Why a SI engine requires a rich mixture during idling and at full load?
3. What are factors that influence the flame speed?
4. What are the various factors affecting knock in spark ignition engine?
5. State briefly about air motion in CI engines using diagrams.
6. What is the effect of delay period on Knock in CI engines?
7. List the components present in the measuring chain for pressure measurement in engine research.
8. Write about the different types of alternate fuels available.
9. What are the various pollutants present in combustion products?
10. What are emission norms? Give the major pollutants that are to be controlled?

(10 X 3 = 30 marks)

PART B

Answer one full question from each module

Module 1

11. Briefly explain the different air-fuel ratios required for different operating conditions of a gasoline engine? (14 marks)
12. Discuss the air fuel ratio requirements of SI engine? (14 marks)

Module 2

13. Explain the stages of combustion in SI engines with suitable flame propagation curve? (14 marks)
14. What is meant by abnormal combustion. Explain the phenomena of knock in SI engine? (14 marks)

Module 3

15. Explain with figures various types of combustion chambers used in CI engine. (14 marks)
16. Explain the phenomenon of spray evaporation and combustion in CI engine (14 marks)

Module 4

17. Explain the fuel characteristics of biodiesel, CNG,LPG &hydrogen? (14 marks)
18. Discuss about the HCCI engine. (14 marks)

Module 5

19. Write short notes on the formation of particulate and smooth emission in IC engines? (14 marks)
20. Explain in detail about the different methods used for the measurement of exhaust Emission in petrol engine? (14 marks)

Syllabus**Module 1**

Engine design and operating parameters, Thermo chemistry of fuel-air mixtures
Properties of working fluids- unburned mixture composition, burned mixture charts, Exhaust gas composition.

Module 2

Ideal models of engine cycles, Availability analysis of engine processes. Combustion in SI engines- Thermodynamic analysis, Flame structure and speed, Cyclic variations in combustion, partial burning and misfire, abnormal combustion

Module 3

Combustion in CI engines- Phenomenological model of CI engine combustion, Analysis of cylinder pressure data, fuel spray behaviour

Module 4

Utilization of alternate fuels in IC engines- biodiesel, hydrogen, LPG, Natural gas- Advantages and disadvantages- HCCI combustion, ASTM specifications

Module 5

Engine emission and air pollution- Genesis and formation of pollutants, SI engine emission control technology - CI engine emission control technology, fuel quality, emission standards

Text Books:

1. Ganesan, Internal combustion engines, Tata- Mcgraw Hill Publishers, 2002
2. Ramalingam, K.K., Internal Combustion Engines, Scitech Publications (India) Pvt. Ltd., 2004.
3. F Obert, IC Engines and air pollution, Intext educational publishers, 1973
4. Mathur,M.L., and Sharma,R.P., A Course in Internal Combustion Engines, DhanpatRai Publications, 1993.

Reference Books:

1. Heywood JB, IC Engine fundamentals, McGraw hill book Co, 1989
2. W WPulkrabek, Engineering Fundamentals of the IC Engine, 2nd edition, PHI, 2003
3. B. P. Pundir, Engine Emissions: Pollutant formation and advances in control technology, NarosaPublication,2007

Course Contents and Lecture Schedule

No.	Topic	No. of Lectures
1		
1.1	Engine design and operating parameters, Thermo chemistry offuel-air mixtures	4
1.21.2	Properties of working fluids- unburned mixture composition, burned mixture charts, Exhaust gas composition.	3
2	Combustion in SI engines	
2.1	Ideal models of engine cycles, Availability analysis of engine processes.	2
2.2	Thermodynamic analysis, Flame structureand speed, Cyclic variations in combustion, partial burning and misfire,abnormal combustion	5
3	Combustion in CI engines	
3.1	Phenomenological model of CI engine combustion	4
3.2	Analysis of cylinder pressure data, fuel spray behavior	3
4	Utilization of alternate fuels in IC engines	
4.1	Biodiesel, hydrogen, LPG,Natural gas- Advantages and disadvantages	5
4.2	HCCI combustion, ASTMspecifications	2
5	Engine emission and air pollution	
5.1	Genesis and formation of pollutants	1

5.2	SI engine emission control technology	3
5.3	CI engine emission control technology, fuel quality, emission standards	3

APJ ABDUL KALAM
TECHNOLOGICAL
UNIVERSITY

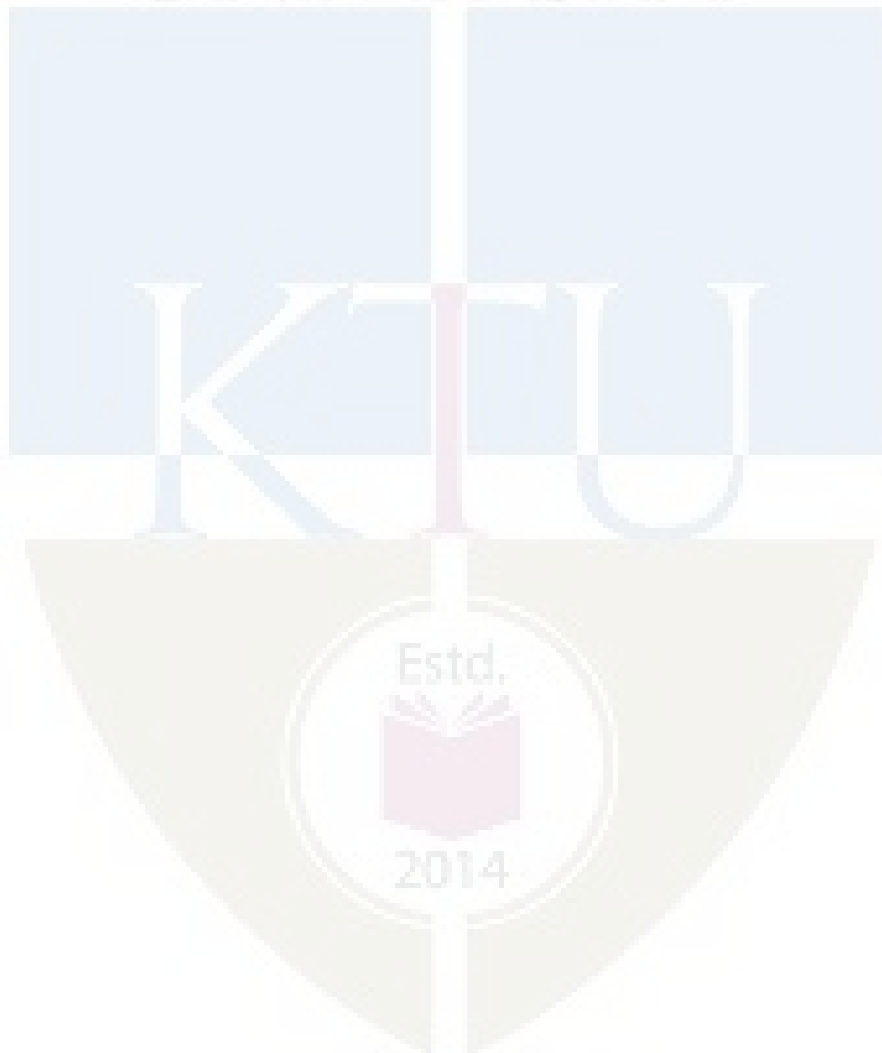

CODE	COURSE NAME	CATEGORY	L	T	P	CREDIT
MET 352	AUTOMOBILE ENGINEERING	PEC	2	1	0	3

Preamble:

The objective of this course is

- To know the anatomy of automobile in general
- To understand the working of different automotive systems and subsystems
- To update the latest developments in automobiles

Prerequisite: EST 120 Basics of Mechanical Engineering

Course Outcomes: After the completion of the course the student will be able to

CO 1	Explain different automotive systems and subsystems .
CO 2	Illustrate the principles of transmission, suspension, steering and braking systems of an automobile.
CO 3	Build a basic knowledge about the technology in electric vehicles.
CO 4	Summarize the concept of aerodynamics in automobiles.

Mapping of course outcomes with program outcomes

	PO1	PO2	PO3	PO4	PO5	PO6	PO7	PO8	PO9	PO10	PO11	PO12
CO1	3											3
CO2	3											3
CO3	3											3
CO4	3											3

Assessment Pattern

Bloom's Category	Continuous Assessment Tests		End Semester Examination
	1	2	
Remember	10	10	10
Understand	20	20	20
Apply	20	20	70
Analyse			
Evaluate			
Create			

Mark distribution

Total Marks	CIE	ESE	ESE Duration
150	50	100	3 hours

Continuous Internal Evaluation Pattern:

Attendance : 10 marks

Continuous Assessment Test (2 numbers) : 25 marks

Assignment/Quiz/Course project : 15 marks

End Semester Examination Pattern: There will be two parts; Part A and Part B. Part A contain 10 questions with 2 questions from each module, having 3 marks for each question. Students should answer all questions. Part B contains 2 questions from each module of which student should answer any one. Each question can have maximum 2 sub-divisions and carry 14 marks.

Course Level Assessment Questions**Course Outcome 1 (CO1):**

1. What is the need of clutch and gearbox in an automobile?
2. List out the factors affecting the maximum torque transmitting capacity of a friction clutch,
3. Define over drive and list out its advantages.

Course Outcome 2 (CO2)

1. Explain Ackermann steering mechanism with a neat sketch.
2. Explain in detail the working and function of ABS braking system.
3. Explain the function and advantages of Double Wishbone Suspension system.

Course Outcome 3 (CO3):

1. What is the difference between an electric vehicle and a hybrid vehicle?
2. List out the differences in the chassis design of an electric vehicle comparing with the conventional chassis.
3. Explain the basic operation of a fuel cell.

Course Outcome 4 (CO4):

1. What is the significance of aerodynamic lift in vehicles?
2. Explain the concept of 'Hatch back Drag'.
3. What are the functions of negative lift aerofoil wings.

Model Question Paper

MECHANICAL ENGINEERING

SIXTH SEMESTER MECHANICAL ENGINEERING

MET 352 AUTOMOBILE ENGINEERING

Max. Marks: 100

Duration: 3 Hours

PART A (30 marks)

Answer all questions, each carries 3 marks.

1. List the three types of chassis construction.
2. Explain the loads coming on a chassis frame.
3. Differentiate body roll couple and body overturning couple.
4. Explain the features of Double Wish Bone suspension system.
5. Describe any type of a regenerative brake system.
6. Illustrate the desirable properties of brake pad materials.
7. Define the terms under steer and over steer in automobiles.
8. Explain the advantages of power assisted steering system.
9. Explain the functions of negative lift aerofoil wings.
10. List out the advantages of rear end spoiler in a vehicle.

PART B (70 marks)

Answer any one question from each module, each carries 14 marks.

Module 1

11.	a)	Explain the working of worm and roller steering gearbox system with the help of a neat sketch.	(7)
	b)	Explain the common troubles encountered in gear boxes and suggest suitable remedies.	(7)
12.		Compare hydraulic, mechanical, electrical and vacuum methods of operating clutches. Describe a hydraulic operated clutch in detail with help of simple	(14)

		diagram.	
Module 2			
13.	a)	Explain the features of McPherson strut suspension system with a neat sketch.	(8)
	b)	Explain the function of an antiroll bar in a four wheeled vehicle.	(6)
14.	a)	Illustrate the working of swing arm rear wheel drive independent suspension.	(8)
	b)	Explain the features of De Dion axle rear wheel suspension.	(6)
Module 3			
15.	a)	Explain how the braking efficiency of a vehicle is evaluated? Also detail the parameters that affect the braking efficiency.	(7)
	b)	Derive an expression for the brakes applied on front and rear wheels.	(7)
16.	a)	Discuss the working and advantages of ABS over conventional systems.	(8)
	b)	Explain the working of a brake caliper with a neat sketch.	(6)
Module 4			
17.	a)	Explain the working and advantages of turbocharger with a neat sketch.	(8)
	b)	Explain how oil control ring helps in piston lubrication.	(6)
18.	a)	Explain the basic principle of a hydrogen fuel cell and its efficiency.	(8)
	b)	Explain the technology of high speed electric trains.	(6)
Module 5			
19.	a)	Differentiate between fast back drag and hatch back drag.	(7)
	b)	Explain the methods to control the aerodynamic lift in vehicles.	(7)
20.	a)	Illustrate the influence of shape of vehicles on drag coefficients.	(7)
	b)	Explain how profile edge chamfering improves drag in vehicles.	(7)

Syllabus

Module 1

Components of an automobile. General classification. Conventional Chassis construction- Types of frames- Frameless constructions. Vehicle dimensions.

Friction clutch: Principle, dry friction clutches- Pull type diaphragm clutch, multiple diaphragm clutch, multi-plate hydraulically operated automatic transmission clutch, semi centrifugal clutch, fully automatic centrifugal clutch, and integral single plate diaphragm clutch. Electromagnetic clutch operation. Clutch friction materials, wet clutch.

Manual transmission- Need of gear box, power to weight ratio, speed operating range-five speed and reverse sliding mesh, constant mesh, and synchromesh gear boxes. Automatic transmission- Epicyclic gear box - torque convertor – Over drives. Automated manual transmission.

Module 2

Suspension: - suspension geometry, terminology- Macpherson strut friction and spring offset - suspension roll centers:-roll centers, roll axis, roll centre height, short swing and long arm suspension, transverse double wishbone, parallel trailing double arm and vertical pill strut suspension, Macpherson strut suspension, semi-trailing arm rear suspension, telescopic suspension. High load beam axle leaf spring, sprung body roll stability. Rear axle beam suspension- body roll stability analysis:- body roll couple, body roll stiffness, body over turning couple.

Rear suspension: - live rigid axle suspension, non drive rear suspension- swing arm rear wheel drive independent suspension. Low pivot split axle coil spring wheel drive independent suspension, trailing and semi trailing arm rear wheel drive independent suspension. Transverse double link arm rear wheel drive independent suspension, De Dion axle rear wheel suspension - Hydrogen suspension, hydro-pneumatic automatic height correction suspension.

Module 3

Brakes: mechanical and hydraulic brakes (review only) – properties of friction lining and pad materials, theory of internal shoe brake, equations –effect of expanding mechanism of shoes on total braking torque, equations. Braking of vehicles:- brakes applied on rear, front and all four wheels, equations –calculation of mean lining pressure and heat generation during braking operation, equations. – braking of vehicle moving on curved path, simple problems.

Anti Lock Braking system (ABS):- hydro-mechanical ABS - hydro-electric ABS - air-electric ABS. Brake servos: - direct acting suspended vacuum assisted brake servo unit operation - hydraulic servo assisted brake systems. Pneumatic operated disc brakes – electronic-pneumatic brakes. Regenerative braking system.

Module 4

Steering:-basic principle of a steering system– Ackermann –over steer and under steer – slip angle, camber, , king pin inclination, caster, toe-in and toe-out .Steering gear box:-worm and roller type steering gear box – Re-circulating ball nut and rocker lever– need of power assisted steering.

Piston for IC engine, piston rings, piston pin, connecting rod, crank shaft, crank pin, cam shaft, valves, fly wheel, fluctuation of energy and size of fly wheel, hub and arms, stress in a fly wheel rim, simple problems. Fuel injection systems: multiport fuel injection (MPFI) and common rail direct injection (CRDI) systems. Super charging in engines, turbo charger, turbo lag.

Electric Vehicle Technology (EVT): EV Architecture, types of batteries, battery parameters, super capacitors. Fuel cells and its efficiency. EV Chassis – requirements, suspension for EVs. Recent Electric vehicles- Electric mobility aids. Future of electric vehicles –Tesla S, Maglev trains, Electric rail road systems.

Module 5

Aerodynamic drag: pressure drag, air resistance, opposing motion of a vehicle, equations, after flow wake, drag coefficients, various body shapes, base drag, vortices, trailing vortex drag, attached transverse vortices. Aerodynamic lift:-lift coefficients, vehicle lift, underbody floor height versus aerodynamic lift and drag, aerofoil lift and drag, front end nose shape.

Car body drag reduction:-profile edge chamfering, bonnet slope and wind screen rake, roof and side panel chamfering, rear side panel taper, under body rear end upward taper, rear end tail extension, under body roughness. Aerodynamic lift control:- under body dams, exposed wheel air flow pattern, partial enclosed wheel air flow pattern, rear end spoiler, negative lift aerofoil wings. After body drag: - square back drag, fast back drag, hatch back drag, notch back drag.

Text Books

1. Heinz Heisler, Vehicle and engine technology, Butterworth-Heinemann, 2nd edition,1998.
2. R.B. Gupta., Auto design , Satya Prakashan Publishers, New Delhi, 2016 .
3. James Larminie and John Lowry, Electric vehicle technology explained, Wiley publications, 2nd edition, 2015.
4. Kirpal Singh, Automobile Engineering Vol.1 & Vol.2, Standard Publishers, 13th edition, 2020.

Reference Books

4. V.A.W. Hillier, Fundamentals of modern vehicle technology, Butterworth-Heinemann, 2nd edition,1998.

5. Tom Denton, Electric and Hybrid Vehicles, Routledge Publishers, 2nd edition, 2020.

Course Contents and Lecture Schedule

No	Topic	No. of Lectures
1	Clutch and transmission	
1.1	Introduction, Chassis construction- Types of frames.	1
1.2	Frameless construction, Vehicle dimensions	1
1.3	Principle of dry friction clutches- Single plate, Multi plate.	1
1.4	Semi centrifugal clutch, fully automatic centrifugal clutch, and	1
1.5	Integral single plate diaphragm clutch. Electromagnetic clutch operation., clutch friction materials, wet clutches	1
1.6	Sliding mesh, constant mesh , synchromesh gear boxes, epicyclic gear boxes	1
1.7	Torque converter, Over drives, Automated manual transmission	1
2	Suspension	
2.1	Suspension: - suspension geometry, terminology. Macpherson strut friction and spring offset.	1
2.2	Suspension roll centers:-roll centers, roll axis, roll centre height, short swing and long arm suspension.	1
2.3	Transverse double wishbone, parallel trailing double arm and vertical pill strut suspension, Macpherson strut suspension, semi-trailing arm rear suspension, telescopic suspension.	1
2.4	High load beam axle leaf spring, sprung body roll stability. Rear axle beam suspension- body roll stability analysis:- body roll couple, body roll stiffness, body over turning couple.	1
2.5	Rear suspension: - live rigid axle suspension, non drive rear suspension- swing arm rear wheel drive independent suspension.	1
2.6	Low pivot split axle coil spring wheel drive independent suspension, trailing and semi trailing arm rear wheel drive independent suspension.	1
2.7	Transverse double link arm rear wheel drive independent suspension, De Dion axle rear wheel suspension. Hydrogen suspension, hydro-pneumatic automatic height correction suspension.	1
3	Brakes	
3.1	Types of Brakes, Properties of friction lining and pad materials.Theory	1

	of internal shoe brake, equations	
3.2	Effect of expanding mechanism of shoes on total braking torque, equations.	1
3.3	Braking of vehicles:- brakes applied on rear, front and all four wheels, equations.	1
3.4	Calculation of mean lining pressure and heat generation during braking operation, equations.	1
3.5	Braking of vehicle moving on curved path, simple problems. Hydro-mechanical ABS - hydro-electric ABS	1
3.6	Air-electric ABS. Brake servos: -direct acting suspended vacuum assisted brake servo unit operation - Hydraulic servo assisted brake systems.	1
3.7	Pneumatic operated disc brakes – electronic-pneumatic brakes. Regenerative braking systems.	1
4 Steering, Engine and EVT		
4.1	Ackermann steering mechanism, over steer and under steer .	1
4.2	Worm and roller type steering gear box, Re-circulating ball nut and rocker lever, power assisted steering.	1
4.3	IC engines, piston, rings, pin, flywheel, connecting rod.Crank shaft, crank pin, cam shaft, valve mechanism	1
4.4	Fuel injection systems ,Turbochargers, turbo lag.	1
4.5	EV Architecture, types of batteries, battery parameters, super capacitors. Fuel cells and its efficiency.	1
4.6	EV Chassis – requirements, suspension for EVs. Recent Electric vehicles- Electric mobility aids.	1
4.7	Future of electric vehicles –Tesla S, Maglev trains, Electric rail road systems.	1
5 Aerodynamics in automobiles		
5.1	Aerodynamic drag: pressure drag, air resistance, opposing motion of a vehicle.	1
5.2	Flow wake, drag coefficients, various body shapes, base drag, vortices, trailing vortex drag, attached transverse vortices.	1
5.3	Aerodynamic lift:-lift coefficients, vehicle lift. Under body floor height versus aerodynamic lift and drag.Aerofoil lift and drag, front end nose	1

	shape.	
5.4	Car body drag reduction:-profile edge chamfering, bonnet slope and wind screen rake.	1
5.5	Roof and side panel chamfering, rear side panel taper, under body rear end upward taper, rear end tail extension, under body roughness.	1
5.6	Aerodynamic lift control:- under body dams, exposed wheel air flow pattern, partial enclosed wheel air flow pattern, rear end spoiler, negative lift aerofoil wings.	1
5.7	After body drag: - square back drag, fast back drag, hatch back drag, notch back drag.	1

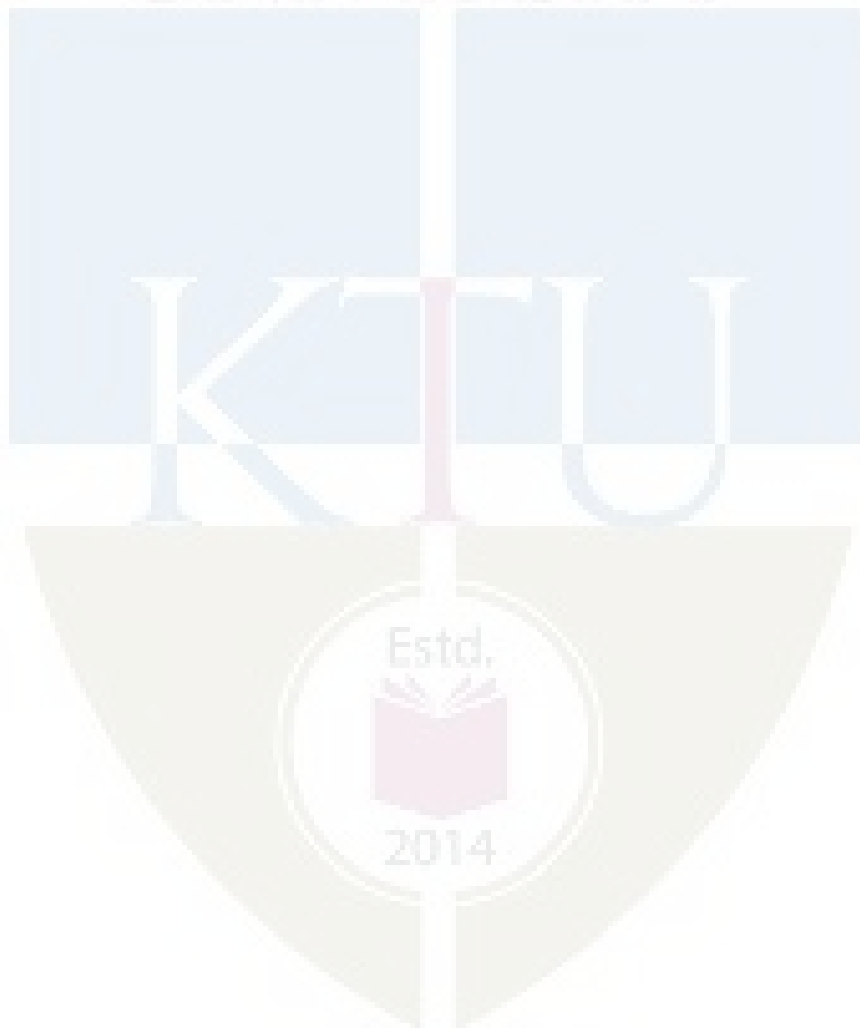

CODE MET362	COURSE NAME PRODUCT DESIGN AND DEVELOPMENT	CATEGORY	L	T	P	CREDIT
		PEC	2	1	0	3

Preamble:

- To create confidence in developing new products.
- To acquaint with methods and tools for product design and development.
- To equip with practical knowledge in conceptualization, design and development of new product.

Prerequisite: NIL

Course Outcomes: After the completion of the course the student will be able to

CO 1	Determine the life cycle of a product and product development process
CO 2	Develop knowledge of robust design and conceptual design
CO 3	Introduce the concept of Design for Manufacturing and Assembly in product design.
CO 4	Use value engineering in the development of product
CO 5	Incorporate ergonomics and rapid prototyping in product development.

Mapping of course outcomes with program outcomes

	PO 1	PO 2	PO 3	PO 4	PO 5	PO 6	PO 7	PO 8	PO 9	PO 10	PO 11	PO 12
CO 1	3	3	2									
CO 2	3	3	2									
CO 3	3	3	2									
CO 4	3	3	2									
CO 5	3	3	2									

Assessment Pattern

Bloom's Category	Continuous Assessment Tests		End Semester Examination
	1	2	
Remember	10	10	10
Understand	20	20	20
Apply	20	20	70
Analyse			
Evaluate			
Create			

Mark distribution

Total Marks	CIE	ESE	ESE Duration
150	50	100	3 hours

Continuous Internal Evaluation Pattern:

Attendance	: 10 marks
Continuous Assessment Test (2 numbers)	: 25 marks
Assignment/Quiz/Course project	: 15 marks

End Semester Examination Pattern: There will be two parts; Part A and Part B. Part A contain 10 questions with 2 questions from each module, having 3 marks for each question. Students should answer all questions. Part B contains 2 questions from each module of which student should answer any one. Each question can have maximum 2 sub-divisions and carry 14 marks.

Course Level Assessment Questions**Course Outcome 1 (CO1):**

1. State the features of a good product design.
2. Explain the morphology of design.
3. Describe about the product life cycle.

Course Outcome 2 (CO2)

1. Discuss the brainstorming technique.
2. Discuss about the robust design.
3. Describe the industrial design process.

Course Outcome 3(CO3):

1. Explain DFM Method in design.
2. Explain the importance of ergonomics in product design.
3. Explain the environmental impacts derived from the manufacturing sector.

Course Outcome 4 (CO4):

1. Discuss the advantages of value analysis.
2. Compare Value analysis and value engineering.
3. Discuss some of the quantitative economic analysis tool used in industry.

Course Outcome 5 (CO5):

1. Describe the steps in reverse engineering.
2. Explain the concept of Concurrent Engineering, Rapid prototyping
3. Explain about the patenting system.

MODEL QUESTION PAPER

**APJ ABDUL KALAM TECHNOLOGICAL UNIVERSITY
SIXTH SEMESTER B. TECH DEGREE EXAMINATION
Course Code: MET362**

Course Name: PRODUCT DESIGN AND DEVELOPMENT

Max. Marks: 100

Duration: 3 Hours

PART – A

(ANSWER ALL QUESTIONS, EACH QUESTION CARRIES 3 MARKS)

1. How the different types of products are classified?
2. What are the various reasons for the failure of a new product?
3. What are three accuracy points in cam and follower synthesis?
4. What meant by the term “lines of maintenance”?
5. Analyze the corporate social responsibility in ethical view point?
6. Differentiate between fixed cost and variable cost?
7. Explain the term anthropometry?
8. What are the rights of a patentee?
9. Differentiate between drafting and modelling software with suitable examples?
10. Explain different steps in a 3d scanning process

PART – B

(ANSWER ONE FULL QUESTION FROM EACH MODULE)

Module 1

11. Explain the various steps involved the morphology of design? (14 marks)
12. Analyze the steps and responsibilities involved in the development of a new product with the help of an example? (14 marks)

Module 2

13. Discuss the various steps in robust design process? (14 marks)
14. Analyze the various activities involved in the industrial design process? (14marks)

Module 3

15. a) Elaborate the role of ergonomic factors in product design? (8 marks)
- b) Analyze the ergonomic factors that need to be considered in the design of a chair? (6 marks)

16. Explain how the design for assembly affects the product design with the help of two examples?

(14 marks)

Module 4

17. Define Value Engineering. Explain the application of the value engineering concept with the help of two case studies?

(14 marks)

18. How the cost of a product is determined? Explain with suitable example.

(14 marks)

Module 5

19. Analyze the major factors that contribute to the improved product quality by incorporating the concurrent engineering concept?

(14 marks)

20. Explain Stereo-lithography and Fused Deposition Modeling with sketch. Compare the advantages and disadvantages of these techniques?

(14 marks)

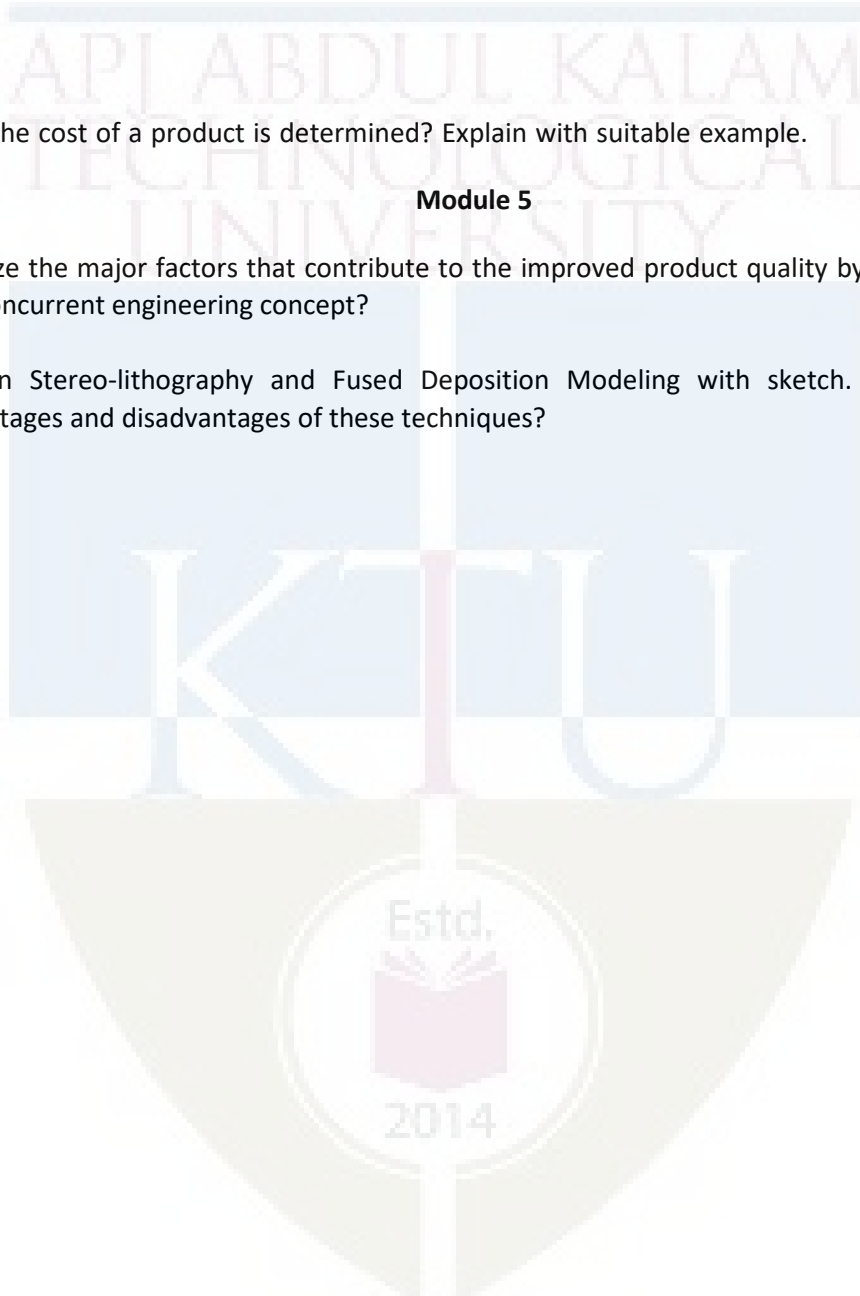

Module 1

Introduction: Classification/ Specifications of Products, Product life cycle, product mix.

Introduction to product design, Modern product development process Design by evolution, Design by innovation, Morphology of design

Ethics in product design, legal factors and social issues.

Module 2

Creativity Techniques: Creative thinking, conceptualization, brain storming, primary design, drawing, simulation, detail design.

Conceptual Design: Generation, selection & embodiment of concept, Product architecture.

Industrial design: process, need.

Robust Design: Taguchi Designs, Design of experiments.

Module 3

Design for Manufacturing and Assembly: Methods of designing for Manufacturing and Assembly.

Design for Maintenance. Design for Environment.

Ergonomics in product design.

Aesthetics in product design. Concepts of size and texture color.

Module 4

Value Engineering / Value Analysis: Definition. Methodology, Case studies.

Product costing.

Economic analysis: Qualitative & Quantitative.

Psychological and Physiological considerations.

Module 5

Concurrent Engineering -Elements of concurrent engineering, Benefits

Rapid prototyping: concepts, processes and advantages.

Reverse engineering: steps in reverse engineering- hardware and software in reverse engineering

Tools for product design – Drafting / Modeling software.

Patents & IP Acts- Overview, Disclosure preparation.

Text Books

MECHANICAL ENGINEERING

1. Karl T Ulrich, Steven D Eppinger, “Product Design & Development.” Tata McGraw Hill, 2003.

Reference Books

1. Baldwin E N & Neibel B W “Designing for Production.” Edwin Homewood Illinois.
2. Bralla J G (Ed.), “Handbook of Product Design for Manufacture, McGraw Hill, New York, 1986
3. D. T. Pham, S.S. Dimov, Rapid Manufacturing-The Technologies and Applications of Rapid Prototyping and Rapid Tooling, Springer – Verlag, London, 2001.
4. David G Ullman, “The Mechanical Design Process.” McGraw Hill Inc Singapore 1992
5. Hollins B & Pugh S “Successful Product Design.” Butter worths London, 1990
6. Jones J C “Design Methods.” Seeds of Human Futures. John Willey, 1970
7. Kevin Otto & Kristin Wood Product Design: “Techniques in Reverse Engineering and new Product Development.”, Pearson Education New Delhi, 2000
8. N J M Roozenberg , J Ekels , N F M Roozenberg “ Product Design Fundamentals and Methods .” John Willey & Sons 1995.
9. Andreas Gebhardt, Rapid Prototyping, Carl Hanser – Verlag, Munich, 2003.

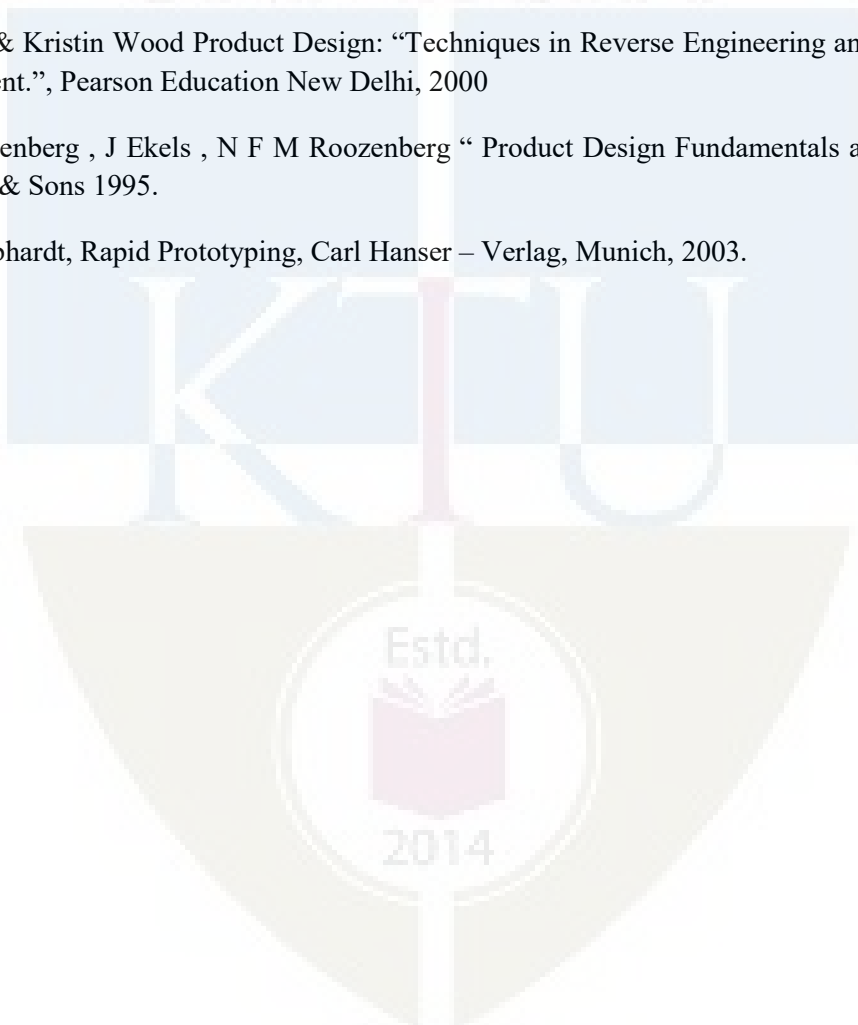

Course Contents and Lecture Schedule

MECHANICAL ENGINEERING

No	Topic	No. of Lectures
1	Module 1	6
1.1	Introduction: Classification/ Specifications of Products. Product life cycle.	2
1.2	Product mix. Introduction to product design. Modern product development process.	2
1.3	Innovative thinking. Morphology of design. Ethics in product design Ethics in product design	2
2	Module 2	6
2.1	Creativity Techniques, Conceptual Design: Generation, selection & embodiment of concept.	2
2.2	Product architecture. Industrial design: process, need.	2
2.3	Robust Design: Taguchi Designs & DOE.	2
3	Module 3	7
3.1	Design for Manufacturing and Assembly: Methods of designing for Manufacturing and Assembly.	3
3.2	Designs for Maintainability. Designs for Environment. Product costing.	2
3.3	Ergonomics in product design. Aesthetics in product design.	2
4	Module 4	7
4.1	Value Engineering / Value Analysis: Definition. Methodology,	3
4.2	Case studies.	2
4.3	Economic analysis: Qualitative & Quantitative. Product costing.	2
5	Module 5	9
5.1	Concurrent Engineering, Rapid prototyping: concepts, processes and advantages.	3
5.2	Reverse engineering: steps in reverse engineering- hardware and software in reverse engineering	2
5.3	Tools for product design – Drafting / Modelling software.	2
5.4	Patents & IP Acts. Overview, Disclosure preparation.	2

Estd.
2014

CODE	ADVANCED METAL JOINING TECHNIQUES	CATEGORY	L	T	P	Credits
MET372		PEC	2	1	0	3

Preamble:

This course provides student to learn fundamental concepts of advanced welding techniques and their applications to an extent to enable the learner to arrive at a firsthand conclusion on selection of a particular technique best suited to resolve a metal joining problem.

Prerequisite: MET204 Manufacturing process.

Course Outcomes: After the completion of the course the student will be able to:

CO 1	Explain the physics, equipment, applications of EBW and LBW.
CO 2	Summarise the physics, equipment, applications of diffusion welding and adhesive bonding processes.
CO 3	Contrast the physics, equipment, applications of explosive welding with friction welding.
CO 4	Outline the physics, equipment, applications of ultrasonic welding and brazing.
CO 5	Illustrate the physics, equipment, applications of plasma arc welding and magnetically impelled arc butt welding.
CO 6	Select an appropriate welding technique to resolve a metal joining problem.

Mapping of course outcomes with program outcomes:

	PO 1	PO 2	PO 3	PO 4	PO 5	PO 6	PO 7	PO 8	PO 9	PO 10	PO 11	PO 12
CO 1	3	-	-	-	-	-	-	-	-	-	-	2
CO 2	2	-	-	-	-	-	-	-	-	-	-	2
CO 3	2	-	-	2	-	-	-	-	-	-	-	3
CO 4	3	-	2	-	-	-	-	-	-	-	-	2
CO 5	2	-	-	-	1	-	-	-	-	-	-	2
CO 6	3	-	-	-	2	-	-	-	-	-	-	1

Assessment Pattern

Bloom's Category	Continuous Assessment Tests		End Semester Examination (marks)
	1 (marks)	2 (marks)	
Remember	20	20	40
Understand	20	20	40
Apply	10	10	20
Analyse	-	-	-
Evaluate	-	-	-
Create	-	-	-

Mark distribution

Total Marks	CIE	ESE	ESE Duration
150	50	100	3 hours

Continuous Internal Evaluation Pattern:

Attendance : 10 marks

Continuous Assessment Test (2 numbers) : 25 marks

Assignment/Quiz/Course project : 15 marks

End Semester Examination Pattern: There will be two parts; Part A and Part B. Part A contain 10 questions with 2 questions from each module, having 3 marks for each question. Students should answer all questions. Part B contains 2 questions from each module of which student should answer any one. Each question can have maximum 2 sub-divisions and carry 14 marks.

Course Level Assessment Questions.**Course Outcome 1 (CO1):**

1. Explain principle of operation of Electron Beam Welding.
2. Illustrate a typical EBW gun.
3. List 2 applications of laser beam welding. Identify the inherent process capability of LBM which makes it suitable for above listed applications.

Course Outcome 2 (CO2):

1. With the help of suitable diagrams, describe various stages in diffusion welding process.
2. Describe various diffusion welding methods.
3. Explain the physics of adhesive bonding.

Course Outcome 3 (CO3):

1. With the help of suitable diagram, describe parallel stand-off and angular stand-off.
2. Compare the mechanism of metal joining in explosive welding with that of friction welding. Give one application for each.
3. Show the effect of rotational speed on duration of friction welding.

Course Outcome 4 (CO4):

1. Describe principle of operation of ultrasonic welding.
2. List all design considerations for a brazed joint.

3. Make a note on hand torch brazing.

Course Outcome 5 (CO5):

1. Differentiate transferred and non-transferred plasma arc processes.
2. Sketch and explain a plasma arc welding system.
3. Describe the steps involved in MIAB with appropriate diagrams.

Course Outcome 6 (CO6):

1. Select a welding process which is considered relatively best for underwater welding. Correlate relevant process capability of the selected technique to support your selection.
2. Select a welding process that is considered best for welding stainless steel. Correlate relevant process capability of the selected technique to support your selection.
3. Suggest a best welding technique to join materials having thin sections. Explain why.

Model Question Paper
SIXTH SEMESTER MECHANICAL ENGINEERING
MET372 ADVANCED METAL JOINING TECHNIQUES

Max. Marks: 100

Duration: 3 hours

Part–A

Answer all questions. Each question carries 3 marks.

1. Draw typical joint designs for electron beam welding.
2. How do you define “f number” for a laser beam?
3. What is vacuum fusion bonding?
4. Write a short note on crack extension test performed on adhesive bonds.
5. What is Impact velocity? How critical is it in creating an explosive weld?
6. Sketch and mark a simple friction welding setup.
7. What is principle of operation of ultrasonic welding?
8. List down essential properties of brazing filler metals.
9. What is “keyholing” in plasma arc welding?
10. What are the advantages of magnetically impelled arc butt welding?

Part–B

Answer one full question from each module.

Module I

11. (a) Draw and explain an EBW equipment. (7 marks)
(b) Discuss all joint configurations commonly used for LBW. (7 marks)

12. (a) Discuss process characteristics of EBW. (7 marks)

(b) Discuss Carbon Dioxide lasers used for welding. (7 marks)

MECHANICAL ENGINEERING

Module II

13. Explain the theory of diffusion welding process. (14 marks)

14. Classify adhesives used for adhesive bonding and explain their characteristics. (14 marks)

Module III

15. With the help of a neat diagram describe different stages in explosion welding. (14 marks)

16. Draw and explain various joint designs employed in friction welding. (14 marks)

Module IV

17. State and explain all variables in ultrasonic welding. (14 marks)

18. Write short notes on (i) torch brazing (ii) furnace brazing (iii) vacuum brazing (14 marks)

Module V

19. Explain the principle of operation of MIAB welding and steps involved in it with the help of suitable diagrams. (14 marks)

20. Describe the components of a Plasma Arc Welding system and list all applications of PAW. (14 marks)

Syllabus

Module 1

Radiant energy welding: Electron Beam Welding (EBW) - principle and theory- equipment and systems- process characteristics and variables- weld joint design- applications- EBW process variants. Laser Beam Welding-principle and theory-operation-types of lasers-process variables and characteristics-applications.

Module 2

Diffusion welding-principle and theory-methods- welding parameters-advantages and limitations-applications. Cold pressure welding-process, equipment and set-up-applications. Adhesive Bonding-principle and theory-types of adhesives-joint design-bonding methods- applications.

Module 3

Explosive welding-principle and theory-process variables-equipment-joint design-advantages and limitations-applications. Friction welding-principle and theory-process variables-advantages and limitations-applications. Friction stir welding- metal flow phenomena-tools-process variables – applications.

Module 4

Ultrasonic welding-principle and theory-process variables and equipment-types of ultrasonic welds-advantages and limitations-applications. Brazing- principle- brazing processes-torch brazing- furnace brazing- vacuum brazing-induction brazing-advantages and limitations-applications.

Module 5

Plasma arc welding –principle and theory- transferred arc and non-transferred arc techniques-equipment-advantages and limitations-applications. Magnetically impelled arc butt (MIAB) welding-principle of operation-applications. Under water welding-wet and dry under water welding- set-up for underwater welding systems.

Text Books

1. Parmar R.S., Welding Processes and Technology, Khanna Publishers, Delhi, 1998.

Reference Books

1. ASM Metals Handbook “Welding and Brazing”, Vol.6, ASM, Ohio, 1988
2. Parmar R.S., “Welding Engineering and Technology” Khanna Publishers, Delhi, 1997
3. Rossi, B.E., Welding Engineering, Mc Graw-Hill, 1954
4. Schwartz M.M., “Metal Joining Manual”, McGraw-Hill Inc., 1979
5. Udin et al., Welding for Engineers, John Wiley & Sons, New York, 1967
6. Welding Engineers Handbook – ASHE Vol. I, II, III, IV

Course Contents and Lecture Schedule

No.	Topic	No. of Lectures	COs
1.1	Radiant energy welding: Principle of Electron Beam Welding and theory.	1	CO1
1.2	Types of EBW welding guns.	1	CO1
1.3	EBW equipment and systems.	1	CO1
1.4	Process variables –effect of beam current on weld penetration-effect of	1	CO1

	welding speed on weld penetration.		
1.5	Process variants of EBW-medium vacuum EBW and non-vacuum EBW.	1	CO1
1.6	Typical weld joint design and preparation for EBW.	1	CO1
1.7	Weldable materials using EBW and applications of EBW.	1	CO1CO6
1.8	Principle of Laser Beam Welding, mechanism and operation- types of laser systems- process variables and characteristics.	1	CO1
1.9	Weld joint design – weldable materials and applications of laser beam welding.	1	CO1 CO6
2.1	Diffusion welding- principle and theory.	1	CO2
2.2	Diffusion welding methods- Gas-pressure bonding, Vacuum fusion bonding, Eutectic fusion bonding.	1	CO2
2.3	Diffusion welding parameters.	1	CO2
2.4	Weldable materials using diffusion welding- advantages, limitations and applications.	1	CO2 CO6
2.5	Cold pressure welding equipment and set-up-applications.	1	CO2
2.6	Adhesive bonding- principle and theory- classification of adhesives and types of adhesive materials.	1	CO2
2.7	Joint design and bonding methods – applications.	1	CO2 CO6
3.1	Explosive welding- principle and theory- process variables.	1	CO3
3.2	Set-up for explosion welding- Joint design- advantages and limitations- applications.	1	CO3
3.3	Friction welding- principle and theory- process variables.	2	CO3
3.4	Effect of rotational speed on duration of welding- process characteristics.	1	CO3
3.5	Advantages and limitations-applications. Variants of friction welding- friction stir welding-metal flow phenomena.	2	CO3 CO6
4.1	Ultrasonic welding- principle and theory.	1	CO4
4.2	Ultrasonic process variables and equipment-types of ultrasonic welds.	1	CO4
4.3	Advantages and disadvantages of ultrasonic welding- applications.	1	CO4 CO6
4.4	Brazing-principle-brazing processes- torch brazing- furnace brazing- vacuum brazing-induction brazing-advantages and limitations- applications.	2	CO4
5.1	Plasma Arc welding –principle and theory- transferred arc and non-transferred arc processes.	1	CO5
5.2	Plasma arc welding system.	1	CO5
5.3	Advantages, limitations and applications.	1	CO5 CO6
5.4	Magnetically Impelled Arc Butt (MIAB) welding- principle of operation-applications.	2	CO5 CO6
5.5	Under water welding techniques – wet and dry welding- general arrangement for underwater welding systems.	2	CO5

HUT 300	Industrial Economics & Foreign Trade	Category	L	T	P	CREDIT
		HSMC	3	0	0	3

Preamble: To equip the students to take industrial decisions and to create awareness of economic environment.

Prerequisite: Nil

Course Outcomes: After the completion of the course the student will be able to

CO1	Explain the problem of scarcity of resources and consumer behaviour, and to evaluate the impact of government policies on the general economic welfare. (Cognitive knowledge level: Understand)
CO2	Take appropriate decisions regarding volume of output and to evaluate the social cost of production. (Cognitive knowledge level: Apply)
CO3	Determine the functional requirement of a firm under various competitive conditions. (Cognitive knowledge level: Analyse)
CO4	Examine the overall performance of the economy, and the regulation of economic fluctuations and its impact on various sections in the society. (Cognitive knowledge level: Analyse)
CO5	Determine the impact of changes in global economic policies on the business opportunities of a firm. (Cognitive knowledge level: Analyse)

Mapping of course outcomes with program outcomes

	PO1	PO2	PO3	PO4	PO5	PO6	PO7	PO8	PO9	PO10	PO11	PO12
CO1	2										3	
CO2	2	2			2	2	3				3	
CO3	2	2	1								3	
CO4	2	2	1			1					3	
CO5	2	2	1								3	

Abstract POs defined by National Board of Accreditation			
PO#	Broad PO	PO#	Broad PO
PO1	Engineering Knowledge	PO7	Environment and Sustainability
PO2	Problem Analysis	PO8	Ethics
PO3	Design/Development of solutions	PO9	Individual and team work
PO4	Conduct investigations of complex problems	PO10	Communication
PO5	Modern tool usage	PO11	Project Management and Finance
PO6	The Engineer and Society	PO12	Lifelong learning

Assessment Pattern

Bloom's Category	Continuous Assessment Tests		End Semester Examination Marks
	Test 1 (Marks)	Test 2 (Marks)	
Remember	15	15	30
Understand	20	20	40
Apply	15	15	30

Mark Distribution

Total Marks	CIE Marks	ESE Marks	ESE Duration
150	50	100	3 hours

Continuous Internal Evaluation Pattern:

Attendance	: 10 marks
Continuous Assessment - Test (2 numbers)	: 25 marks
Continuous Assessment - Assignment	: 15 marks

Internal Examination Pattern:

Each of the two internal examinations has to be conducted out of 50 marks. First series test shall be preferably conducted after completing the first half of the syllabus and the second series test shall be preferably conducted after completing remaining part of the syllabus. There will be two parts: Part A and Part B. Part A contains 5 questions (preferably, 2 questions each from the completed modules and 1 question from the partly completed module), having 3 marks for each question adding up to 15 marks for part A. Students should answer all questions from Part A. Part B contains 7 questions (preferably, 3 questions each from the completed modules and 1 question from the partly completed module), each with 7 marks. Out of the 7 questions, a student should answer any 5.

End Semester Examination Pattern:

There will be two parts; Part A and Part B.

Part A : 30 marks

Part B : 70 marks

Part A contains 10 questions with 2 questions from each module, having 3 marks for each question. Students should answer all questions. Part B contains 2 questions from each module of which a student should answer any one. Each question can have maximum 3 sub-divisions and carries 14 marks.

SYLLABUS

HUT 300 Industrial Economics & Foreign Trade

Module 1 (Basic Concepts and Demand and Supply Analysis)

Scarcity and choice - Basic economic problems- PPC – Firms and its objectives – types of firms – Utility – Law of diminishing marginal utility – Demand and its determinants – law of demand – elasticity of demand – measurement of elasticity and its applications – Supply, law of supply and determinants of supply – Equilibrium – Changes in demand and supply and its effects – Consumer surplus and producer surplus (Concepts) – Taxation and deadweight loss.

Module 2 (Production and cost)

Production function – law of variable proportion – economies of scale – internal and external economies – Isoquants, isocost line and producer's equilibrium – Expansion path – Technical progress and its implications – Cobb-Douglas production function - Cost concepts – Social cost: private cost and external cost – Explicit and implicit cost – sunk cost - Short run cost curves - long run cost curves – Revenue (concepts) – Shutdown point – Break-even point.

Module 3 (Market Structure)

Perfect and imperfect competition – monopoly, regulation of monopoly, monopolistic completion (features and equilibrium of a firm) – oligopoly – Kinked demand curve – Collusive oligopoly (meaning) – Non-price competition – Product pricing – Cost plus pricing – Target return pricing – Penetration pricing – Predatory pricing – Going rate pricing – Price skimming.

Module 4 (Macroeconomic concepts)

Circular flow of economic activities – Stock and flow – Final goods and intermediate goods - Gross Domestic Product - National Income – Three sectors of an economy- Methods of measuring national income – Inflation- causes and effects – Measures to control inflation- Monetary and fiscal policies – Business financing- Bonds and shares -Money market and Capital market – Stock market – Demat account and Trading account - SENSEX and NIFTY.

Module 5 (International Trade)

Advantages and disadvantages of international trade - Absolute and Comparative advantage theory - Heckscher - Ohlin theory - Balance of payments – Components – Balance of Payments

deficit and devaluation – Trade policy – Free trade versus protection – Tariff and non-tariff barriers.

Reference Materials

1. Gregory N Mankiw, 'Principles of Micro Economics', Cengage Publications
2. Gregory N Mankiw, 'Principles of Macro Economics', Cengage Publications
3. Dwivedi D N, 'Macro Economics', Tata McGraw Hill, New Delhi.
4. Mithani D M, 'Managerial Economics', Himalaya Publishing House, Mumbai.
5. Francis Cherunilam, 'International Economics', McGraw Hill, New Delhi.

Sample Course Level Assessment Questions

Course Outcome 1 (CO1):

1. Why does the problem of choice arise?
2. What are the central problems?
3. How do we solve the basic economic problems?
4. What is the relation between price and demand?
5. Explain deadweight loss due to the imposition of a tax.

Course Outcome 2 (CO2):

1. What is shutdown point?
2. What do you mean by producer equilibrium?
3. Explain break-even point;
4. Suppose a chemical factory is functioning in a residential area. What are the external costs?

Course Outcome 3 (CO3):

1. Explain the equilibrium of a firm under monopolistic competition.
2. Why is a monopolist called price maker?
3. What are the methods of non-price competition under oligopoly?

4. What is collusive oligopoly?

Course Outcome 4 (CO4):

1. What is the significance of national income estimation?
2. How is GDP estimated?
3. What are the measures to control inflation?
4. How does inflation affect fixed income group and wage earners?

Course Outcome 5 (CO5):

1. What is devaluation?
2. Suppose a foreign country imposes a tariff on Indian goods. How does it affect India's exports?
3. What is free trade?
4. What are the arguments in favour of protection?

Model Question paper

QP CODE:

PAGES:3

Reg No: _____

Name : _____

**APJ ABDUL KALAM TECHNOLOGICAL UNIVERSITY FIFTH /SIXTH SEMESTER
B.TECH DEGREE EXAMINATION, MONTH & YEAR**

Course Code: HUT 300

Course Name: Industrial Economics & Foreign Trade

Max.Marks:100

Duration: 3 Hours

PART A

Answer all Questions. Each question carries 3 Marks

1. Why does an economic problem arise?
2. What should be the percentage change in price of a product if the sale is to be increased by 50 percent and its price elasticity of demand is 2?
3. In the production function $Q = 2L^{1/2}K^{1/2}$ if $L=36$ how many units of capital are needed to produce 60 units of output?
4. Suppose in the short run $AVC < P < AC$. Will this firm produce or shut down? Give reason.
5. What is predatory pricing?
6. What do you mean by non- price competition under oligopoly?
7. What are the important economic activities under primary sector?
8. Distinguish between a bond and share?
9. What are the major components of balance of payments?

10. What is devaluation?

(10 x 3 = 30 marks)

PART B

(Answer one full question from each module, each question carries 14 marks)

MODULE I

11. a) Prepare a utility schedule showing units of consumption, total utility and marginal utility, and explain the law of diminishing marginal utility. Point out any three limitations of the law.
- b) How is elasticity of demand measured according to the percentage method? How is the measurement of elasticity of demand useful for the government?

Or

12. a) Explain the concepts consumer surplus and producer surplus.
- b) Suppose the government imposes a tax on a commodity where the tax burden met by the consumers. Draw a diagram and explain dead weight loss. Mark consumer surplus, producer surplus, tax revenue and dead weight loss in the diagram.

MODULE II

13. a) What are the advantages of large-scale production?
- b) Explain Producer equilibrium with the help of isoquants and isocost line. What is expansion path?

Or

14. a) Explain break-even analysis with the help of a diagram.
- b) Suppose the monthly fixed cost of a firm is Rs. 40000 and its monthly total variable cost is Rs. 60000.
- If the monthly sales is Rs. 120000 estimate contribution and break-even sales.
 - If the firm wants to get a monthly profit of Rs.40000, what should be the sales?
- c) The total cost function of a firm is given as $TC=100+50Q - 11Q^2+Q^3$. Find marginal cost when output equals 5 units.

MODULE III

15. a) What are the features of monopolistic competition?
b) Explain the equilibrium of a firm earning supernormal profit under monopolistic competition.

Or

16. a) Make comparison between perfect competition and monopoly.
b) Explain price rigidity under oligopoly with the help of a kinked demand curve.

MODULE IV

17. a) How is national income estimated under product method and expenditure method?
b) Estimate GDPmp, GNPmp and National income

Private consumption expenditure	= 2000 (in 000 cores)
Government Consumption	= 500
NFIA	= -(300)
Investment	= 800
Net=exports	=700
Depreciation	= 400
Net-indirect tax	= 300

Or

18. a) What are the monetary and fiscal policy measures to control inflation?
b) What is SENSEX?

MODULE V

19. a) What are the advantages of disadvantages of foreign trade?
b) Explain the comparative cost advantage.

Or

20. a) What are the arguments in favour protection?
b) Examine the tariff and non-tariff barriers to international trade.

(5 × 14 = 70 marks)

Teaching Plan

Module 1 (Basic concepts and Demand and Supply Analysis)		7 Hours
1.1	Scarcity and choice – Basic economic problems - PPC	1 Hour
1.2	Firms and its objectives – types of firms	1 Hour
1.3	Utility – Law of diminishing marginal utility – Demand – law of demand	1 Hour
1.4	Measurement of elasticity and its applications	1 Hour
1.5	Supply, law of supply and determinants of supply	1 Hour
1.6	Equilibrium – changes in demand and supply and its effects	1 Hour
1.7	Consumer surplus and producer surplus (Concepts) – Taxation and deadweight loss.	1 Hour
Module 2 (Production and cost)		7 Hours
2.1	Productions function – law of variable proportion	1 Hour
2.2	Economies of scale – internal and external economies	1 Hour
2.3	producers equilibrium – Expansion path	1 Hour
2.4	Technical progress and its implications – cob Douglas Production function	1 Hour
2.5	Cost concepts – social cost: private cost and external cost – Explicit and implicit cost – sunk cost	1 Hour
2.6	Short run cost curves & Long run cost curves	1 Hour
2.7	Revenue (concepts) – shutdown point – Break-even point.	1 Hour
Module 3 (Market Structure)		6 hours
3.1	Equilibrium of a firm, MC – MR approach and TC – TR approach	1 Hour
3.2	Perfect competition & Imperfect competition	1 Hour
3.3	Monopoly – Regulation of monopoly – Monopolistic competition	1 Hour
3.4	Oligopoly – kinked demand curve	1 Hour
3.5	Collusive oligopoly (meaning) – Non price competition	1 Hour
3.6	Cost plus pricing – Target return pricing – Penetration, Predatory pricing – Going rate pricing – price skimming	1 Hour

Module 4 (Macroeconomic concepts)		7 Hours
4.1	Circular flow of economic activities	1 Hour
4.2	Stock and flow – Final goods and intermediate goods – Gross Domestic Product - National income – Three sectors of an economy	1 Hour
4.3	Methods of measuring national income	1 Hour
4.4	Inflation – Demand pull and cost push – Causes and effects	1 Hour
4.5	Measures to control inflation – Monetary and fiscal policies	1 Hour
4.6	Business financing – Bonds and shares – Money market and capital market	1 Hour
4.7	Stock market – Demat account and Trading account – SENSEX and NIFTY	1 Hour
Module 5 (International Trade)		8 Hours
5.1	Advantages and disadvantages of international trade	1 Hour
5.2	Absolute and comparative advantage theory	2 Hour
5.3	Heckscher – Ohlin theory	1 Hour
5.4	Balance of payments - components	1 Hour
5.5	Balance of payments deficit and devaluation	1 Hour
5.6	Trade policy – Free trade versus protection	1 Hour
5.7	Tariff and non tariff barriers.	1 Hour

HUT 310	Management for Engineers	Category	L	T	P	Credit
		HMC	3	0	0	3

Preamble: This course is intended to help the students to learn the basic concepts and functions of management and its role in the performance of an organization and to understand various decision-making approaches available for managers to achieve excellence. Learners shall have a broad view of different functional areas of management like operations, human resource, finance and marketing.

Prerequisite: Nil

Course Outcomes After the completion of the course the student will be able to

CO1	Explain the characteristics of management in the contemporary context (Cognitive Knowledge level: Understand).
CO2	Describe the functions of management (Cognitive Knowledge level: Understand).
CO3	Demonstrate ability in decision making process and productivity analysis (Cognitive Knowledge level: Understand).
CO4	Illustrate project management technique and develop a project schedule (Cognitive Knowledge level: Apply).
CO5	Summarize the functional areas of management (Cognitive Knowledge level: Understand).
CO6	Comprehend the concept of entrepreneurship and create business plans (Cognitive Knowledge level: Understand).

Mapping of course outcomes with program outcomes

	PO1	PO2	PO3	PO4	PO5	PO6	PO7	PO8	PO9	PO10	PO11	PO12
CO1	2				1	2	2	2		2	1	1
CO2	2				1	1		2	1	2	1	1
CO3	2	2	2	2	1							
CO4	2	2	2	2	1						2	1
CO5	2					1	1		1	2	1	
CO6		2	2	2	1	1	1	1	1	1	1	1

Abstract POs defined by National Board of Accreditation				
PO1	Engineering Knowledge		PO7	Environment and Sustainability
PO2	Problem Analysis		PO8	Ethics
PO3	Design/Development of solutions		PO9	Individual and team work
PO4	Conduct investigations of complex problems		PO10	Communication
PO5	Modern tool usage		PO11	Project Management and Finance
PO6	The Engineer and Society		PO12	Life long learning

Assessment Pattern

Bloom's Category	Test 1 (Marks in percentage)	Test 2 (Marks in percentage)	End Semester Examination (Marks in percentage)
Remember	15	15	30
Understand	15	15	30
Apply	20	20	40
Analyse			
Evaluate			
Create			

Mark Distribution

Total Marks	CIE Marks	ESE Marks	ESE Duration
150	50	100	3 Hours

Continuous Internal Evaluation Pattern:

Attendance : 10 marks

Continuous Assessment - Test : 25 marks

Continuous Assessment - Assignment : 15 marks

Internal Examination Pattern:

Each of the two internal examinations has to be conducted out of 50 marks. First series test shall be preferably conducted after completing the first half of the syllabus and the second series test shall be preferably conducted after completing remaining part of the syllabus. There will be two parts: Part A and Part B. Part A contains 5 questions (preferably, 2 questions each from the completed modules and 1 question from the partly completed module), having 3 marks for each question adding up to 15 marks for part A. Students should answer all questions from Part A. Part B contains 7 questions (preferably, 3 questions each from the completed modules and 1 question from the partly completed module), each with 7 marks. Out of the 7 questions, a student should answer any 5.

End Semester Examination Pattern:

There will be two parts; Part A and Part B. Part A contains 10 questions with 2 questions from each module, having 3 marks for each question. Students should answer all questions. Part B contains 2 questions from each module of which a student should answer any one. Each question can have maximum 2 sub-divisions and carries 14 marks.

SYLLABUS

HUT 310 Management for Engineers (35 hrs)

Module 1 (Introduction to management Theory- 7 Hours)

Introduction to management theory, Management Defined, Characteristic of Management, Management as an art-profession, System approaches to Management, Task and Responsibilities of a professional Manager, Levels of Manager and Skill required.

Module 2 (management and organization- 5 hours)

Management Process, Planning types , Mission, Goals, Strategy, Programmes, Procedures, Organising, Principles of Organisation, Delegation, Span of Control, Organisation Structures, Directing, Leadership, Motivation, Controlling..

Module 3 (productivity and decision making- 7 hours)

Concept of productivity and its measurement; Competitiveness; Decision making process; decision making under certainty, risk and uncertainty; Decision trees; Models of decision making.

. Module 4 (project management- 8 hours)

Project Management, Network construction, Arrow diagram, Redundancy. CPM and PERT Networks, Scheduling computations, PERT time estimates, Probability of completion of project, Introduction to crashing.

Module 5 (functional areas of management- 8 hours)

Introduction to functional areas of management, Operations management, Human resources management, Marketing management, Financial management, Entrepreneurship, Business plans, Corporate social responsibility, Patents and Intellectual property rights.

References:

1. H. Koontz, and H. Weihrich, Essentials of Management: An International Perspective. 8th ed., McGraw-Hill, 2009.
2. P C Tripathi and P N Reddy, Principles of management, TMH, 4th edition, 2008.
3. P. Kotler, K. L. Keller, A. Koshy, and M. Jha, Marketing Management: A South Asian Perspective. 14th ed., Pearson, 2012.
4. M. Y. Khan, and P. K. Jain, Financial Management, Tata-McGraw Hill, 2008.
5. R. D. Hisrich, and M. P. Peters, Entrepreneurship: Strategy, Developing, and Managing a New Enterprise, 4th ed., McGraw-Hill Education, 1997.
6. D. J. Sumanth, Productivity Engineering and Management, McGraw-Hill Education, 1985.
7. K.Ashwathappa, 'Human Resources and Personnel Management', TMH, 3rd edition, 2005.
8. R. B. Chase, Ravi Shankar and F. R. Jacobs, Operations and Supply Chain Management, 14th ed. McGraw Hill Education (India), 2015.

Sample Course Level Assessment Questions

Course Outcome1 (CO1): Explain the systems approach to management?

Course Outcome 2 (CO2): Explain the following terms with a suitable example Goal, Objective, and Strategy.

Course Outcome 3 (CO3): Mr. Shyam is the author of what promises to be a successful novel. He has the option to either publish the novel himself or through a publisher. The publisher is offering Mr. Shyam Rs. 20,000 for signing the contract. If the novel is successful, it will sell 200,000 copies. Else, it will sell 10,000 copies only. The publisher pays a Re. 1 royalty per copy. A market survey indicates that there is a 70% chance that the novel will be successful. If Mr. Shyam undertakes publishing, he will incur an initial cost of Rs. 90,000 for printing and marketing., but each copy sold will net him Rs. 2. Based on the given information and the

decision analysis method, determine whether Mr. Shyam should accept the publisher's offer or publish the novel himself.

Course Outcome 4 (CO4): Explain the concepts of crashing and dummy activity in project management.

Course Outcome 5 (CO5): Derive the expression for the Economic order quantity (EOQ)?

Course Outcome 6 (CO6): Briefly explain the theories of Entrepreneurial motivation.?

Model Question Paper

QP CODE:

PAGES: 4

Reg No: _____

Name: _____

**APJ ABDUL KALAM TECHNOLOGICAL UNIVERSITY
FOURTH SEMESTER B.TECH DEGREE EXAMINATION, MONTH & YEAR**

Course Code: HUT 310

Course name: Management for Engineers

Max Marks: 100

Duration: 3 Hours

PART-A (Answer All Questions. Each question carries 3 marks)

1. "Management is getting things done through other." Elaborate.
2. Comment on the true nature of management. Is it a science or an art?
3. Planning is looking ahead and controlling is looking back. Comment with suitable examples
4. Explain the process of communication?
5. Explain the hierarchy of objectives?
6. Explain the types of decisions?
7. Describe the Economic man model?
8. Explain the concepts of crashing and dummy activity in project management.
9. Differentiate the quantitative and qualitative methods in forecasting.
10. What are the key metrics for sustainability measurement? What makes the measurement and reporting of sustainability challenging?

PART-B (Answer any one question from each module)

11. a) Explain the systems approach to management. (10)
b) Describe the roles of a manager (4)

OR

12. a) Explain the 14 principles of administrative management? **(10)**

b) Explain the different managerial skills **(4)**

13. a) What are planning premises, explain the classification of planning premises. **(10)**

b) Distinguish between strategy and policy. How can policies be made effective. **(4)**

OR

14 a) Explain three motivational theories. **(9)**

b) Describe the managerial grid. **(5)**

15. a) Modern forest management uses controlled fires to reduce fire hazards and to stimulate new forest growth. Management has the option to postpone or plan a burning. In a specific forest tract, if burning is postponed, a general administrative cost of Rs. 300 is incurred. If a controlled burning is planned, there is a 50% chance that good weather will prevail and burning will cost Rs. 3200. The results of the burning may be either successful with probability 0.6 or marginal with probability 0.4. Successful execution will result in an estimated benefit of Rs. 6000, and marginal execution will provide only Rs. 3000 in benefits. If the weather is poor, burning will be cancelled incurring a cost of Rs. 1200 and no benefit. i) Develop a decision tree for the problem. (ii) Analyse the decision tree and determine the optimal course of action. **(8)**

b) Student tuition at ABC University is \$100 per semester credit hour. The Education department supplements the university revenue by matching student tuition, dollars per dollars. Average class size for typical three credit course is 50 students. Labour costs are \$4000 per class, material costs are \$20 per student, and overhead cost are \$25,000 per class. (a) Determine the total factor productivity. (b) If instructors deliver lecture 14 hours per week and the semester lasts for 16 weeks, what is the labour productivity? **(6)**

OR

16. a) An ice-cream retailer buys ice cream at a cost of Rs. 13 per cup and sells it for Rs. 20 per cup; any remaining unsold at the end of the day, can be disposed at a salvage price of Rs. 2.5 per cup. Past sales have ranged between 13 and 17 cups per day; there is no reason to believe that

sales volume will take on any other magnitude in future. Find the expected monetary value and EOL, if the sales history has the following probabilities:
(9)

Market Size	13	14	15	16	17
Probability	0.10	0.15	0.15	0.25	0.35

b) At Modern Lumber Company, Kishore the president and a producer of an apple crates sold to growers, has been able, with his current equipment, to produce 240 crates per 100 logs. He currently purchases 100 logs per day, and each log required 3 labour hours to process. He believes that he can hire a professional buyer who can buy a better quality log at the same cost. If this is the case, he increases his production to 260 crates per 100 logs. His labour hours will increase by 8 hours per day. What will be the impact on productivity (measured in crates per labour-hour) if the buyer is hired? What is the growth in productivity in this case?
(5)

17. a) A project has the following list of activities and time estimates:

Activity	Time (Days)	Immediate Predecessors
A	1	-
B	4	A
C	3	A
D	7	A
E	6	B
F	2	C, D
G	7	E, F
H	9	D
I	4	G, H

(a) Draw the network. (b) Show the early start and early finish times. (c) Show the critical path.
(10)

b) An opinion survey involves designing and printing questionnaires, hiring and training personnel, selecting participants, mailing questionnaires and analysing data. Develop the precedence relationships and construct the project network. **(4)**

OR

18. a) The following table shows the precedence requirements, normal and crash times, and normal and crash costs for a construction project:

Activity	Immediate Predecessors	Required Time (Weeks)		Cost (Rs.)	
		Normal	Crash	Normal	Crash
A	-	4	2	10,000	11,000
B	A	3	2	6,000	9,000
C	A	2	1	4,000	6,000
D	B	5	3	14,000	18,000
E	B, C	1	1	9,000	9,000
F	C	3	2	7,000	8,000
G	E, F	4	2	13,000	25,000
H	D, E	4	1	11,000	18,000
I	H, G	6	5	20,000	29,000

Draw the network. (b) Determine the critical path. (c) Determine the optimal duration and the associated cost. **(10)**

b) Differentiate between CPM and PERT. **(4)**

19. a) What is meant by market segmentation and explain the process of market segmentation **(8)**

b) The Honda Co. in India has a division that manufactures two-wheel motorcycles. Its budgeted sales for Model G in 2019 are 80,00,000 units. Honda's target ending inventory is 10,00,000 units and its beginning inventory is 12,00,000 units. The company's budgeted selling price to its distributors and dealers is Rs. 40,000 per motorcycle. Honda procures all its wheels from an

outside supplier. No defective wheels are accepted. Honda's needs for extra wheels for replacement parts are ordered by a separate division of the company. The company's target ending inventory is 3,00,000 wheels and its beginning inventory is 2,00,000 wheels. The budgeted purchase price is Rs. 1,600 per wheel.

(a) Compute the budgeted revenue in rupees.

(b) Compute the number of motorcycles to be produced.

Compute the budgeted purchases of wheels in units and in rupees.? **(6)**

OR

20. a) a) "Human Resource Management policies and principles contribute to effectiveness, continuity and stability of the organization". Discuss. (b) What is a budget? Explain how sales budget and production budgets are prepared? **(10)**

b) Distinguish between the following: (a) Assets and Liabilities (b) Production concept and Marketing concept (c) Needs and Wants (d) Design functions and Operational control functions in operations **(4)**

Teaching Plan

Sl.No	TOPIC	SESSION
Module I		
1.1	Introduction to management	1
1.2	Levels of managers and skill required	2
1.3	Classical management theories	3
1.4	neo-classical management theories	4
1.5	modern management theories	5
1.6	System approaches to Management,	6
1.7	Task and Responsibilities of a professional Manager	7
Module 2		
2.1	Management process – planning	8
2.2	Mission – objectives – goals – strategy – policies – programmes – procedures	9
2.3	Organizing, principles of organizing, organization structures	10
2.4	Directing, Leadership	11
2.5	Motivation, Controlling	12
Module III		
3.1	Concept of productivity and its measurement Competitiveness	13
3.2	Decision making process;	14
3.3	Models in decision making	15
3.4	Decision making under certainty and risk	16
3.5	Decision making under uncertainty	17
3.6	Decision trees	18
3.7	Models of decision making.	19
Module IV		
4.1	Project Management	20

Sl.No	TOPIC	SESSION
	Module I	
4.2	Network construction	21
4.3	Arrow diagram, Redundancy	22
4.4	CPM and PERT Networks	23
4.5	Scheduling computations	24
4.6	PERT time estimates	25
4.7	Probability of completion of project	26
4.8	Introduction to crashing	
	Module V	
5.1	Introduction to functional areas of management,	28
5.2	Operations management	29
5.3	Human resources management ,	30
5.4	Marketing management	31
5.5	Financial management	32
5.6	Entrepreneurship,	33
5.7	Business plans	34
5.8	Corporate social responsibility, Patents and Intellectual property rights	35

MET308	COMPREHENSIVE COURSE WORK	CATEGORY	L	T	P	CREDIT
		PCC	1	0	0	1

Preamble: The course is designed to ensure that the students have firmly grasped the foundational knowledge in Mechanical Engineering familiar enough with the technological concepts. It provides an opportunity for the students to demonstrate their knowledge in various Mechanical Engineering subjects.

Pre-requisite: Nil

Course outcomes: After the course, the student will able to:

CO1	Learn to prepare for a competitive examination
CO2	Comprehend the questions in Mechanical Engineering field and answer them with confidence
CO3	Communicate effectively with faculty in scholarly environments
CO4	Analyze the comprehensive knowledge gained in basic courses in the field of Mechanical Engineering

Mapping of course outcomes with program outcomes:

	PO 1	PO 2	PO 3	PO 4	PO 5	PO 6	PO 7	PO 8	PO 9	PO 10	PO 11	PO 12
CO 1	3	2										2
CO 2	3	2										2
CO 3	3	2										2
CO 4	2	3										2

Assessment pattern

Bloom's Category	End Semester Examination (Marks)
Remember	25
Understand	15
Apply	5

Analyze	5
Evaluate	
Create	

End Semester Examination Pattern:

A written examination will be conducted by the University at the end of the sixth semester. The written examination will be of objective type similar to the GATE examination. Syllabus for the comprehensive examination is based on following five Mechanical Engineering core courses.

MET203- MECHANICS OF FLUIDS

MET205- METALLURGY AND MATERIAL SCIENCE

MET202- ENGINEERING THERMODYNAMICS

MET204- MANUFACTURING PROCESS

MET301- MECHANICS OF MACHINERY

The written test will be of 50 marks with 50 multiple choice questions (10 questions from each module) with 4 choices of 1 mark each covering all the five core courses. There will be no negative marking. The pass minimum for this course is 25. The course should be mapped with a faculty and classes shall be arranged for practicing questions based on the core courses listed above.

Written examination: 50marks

Total : 50 marks

Course Level Assessment and Sample Questions:

- The shear stress developed in lubricating oil, of viscosity 9.81 poise, filled between two parallel plates 1cm apart and moving with relative velocity of 2 m/s is
 - 20 N/m²
 - 19.62 N/m²
 - 29.62 N/m²
 - 40 N/m²
- For a Newtonian fluid
 - Shear stress is proportional to shear strain
 - Rate of shear stress is proportional to shear strain
 - Shear stress is proportional to rate of shear strain

- (d) Rate of shear stress is proportional to rate of shear strain
3. Atomic packing factor (APF) in the case of copper crystal is
- 0.52
 - 0.68
 - 0.74
 - 1.633
4. What is the approximate strain energy expression for a dislocation of unit length, irrespective of its edge or screw character?
- $G^2b/2$
 - $Gb^2/2$
 - $G^2b/4$
 - $Gb^2/4$
5. Consider the following statements
1. Zeroth law of thermodynamics is related to temperature
 2. Entropy is related to first law of thermodynamics
 3. Internal energy of an ideal gas is a function of temperature and pressure
 4. Van der Waals' equation is related to an ideal gas
- Which of the above statements is/are correct?
- 1 only
 - 2, 3 and 4
 - 1 and 3
 - 2 and 4
6. A gas is compressed in a cylinder by a movable piston to a volume one-half of its original volume. During the process, 300 kJ heat left the gas and the internal energy remained same. What is the work done on the gas?
- 100 kNm
 - 150 kNm
 - 200 kNm
 - 300 kNm
7. Which one of the following casting processes is best suited to make bigger size hollow symmetrical pipes?
- Die casting
 - Investment casting
 - Shell moulding
 - Centrifugal casting
8. In gas welding of mild steel using an oxy-acetylene flame, the total amount of acetylene consumed was 10 litre. The oxygen consumption from the cylinder is
- 5 litre
 - 10 litre
 - 15litre
 - 20 litre
9. The number of inversions for a slider crank mechanism is
- (a) 6 (b) 5 (c) 4 (d) 3

10. Total number of instantaneous centers for a mechanism with n links are

- (a) $n/2$ (b) n (c) $(n-1)/2$ (d) $(n(n-1))/2$

Syllabus

MODULE 1

Fluids and continuum, Physical properties of fluids, Newton's law of viscosity. Ideal and real fluids, Newtonian and non-Newtonian fluids. Fluid Statics- Pressure-density-height relationship, manometers, pressure on plane and curved surfaces, center of pressure, buoyancy, stability of immersed and floating bodies

Kinematics of fluid flow: Eulerian and Lagrangian approaches, classification of fluid flow, stream lines, path lines, streak lines, stream tubes, , stream function and potential function

Equations of fluid dynamics: Differential equations of mass, energy and momentum (Euler's equation), Bernoulli's equation, Pipe Flow: Viscous flow: shear stress and velocity distribution in a pipe Hagen Poiseuille equation. Darcy-Weisbach equation,

MODULE 2

Development of atomic structure - Primary bonds: - characteristics of covalent, ionic and metallic bond - properties based on atomic bonding Crystallography: - SC, BCC, FCC, HCP structures, APF , Miller Indices: - crystal plane and direction - Modes of plastic deformation: - Slip and twinning

Classification of crystal imperfections - forest of dislocation, role of surface defects on crack initiation- Burgers vector –Frank Read source - Correlation of dislocation density with strength and nano concept - high and low angle grain boundaries– driving force for grain growth and applications

Phase diagrams: - need of alloying - classification of alloys - Hume Rothery's rule – equilibrium diagram of common types of binary systems: five types - Coring - lever rule and Gibb's phase rule - Reactions- Detailed discussion on Iron-Carbon equilibrium diagram with micro structure and properties -Heat treatment: - TTT, CCT diagram, applications - Tempering- Hardenability, Jominy end quench test, applications- Surface hardening methods.

MODULE 3

Basic Thermodynamic Concepts Macroscopic and Microscopic viewpoints, Concept of Continuum, Thermodynamic System and Control Volume, Surrounding, Boundaries, Types of Systems, Universe, Thermodynamic properties, Process, Cycle, Thermodynamic Equilibrium, Quasi – static Process, State, Point and Path function. Zeroth Law of Thermodynamics, Measurement of Temperature, reference Points, Temperature Scales.

First law of Thermodynamics - First law applied to Non flow and flow Process- SFEE

Second Law of Thermodynamics, Kelvin-Planck and Clausius Statements, Equivalence of two statements Entropy- Entropy changes in various thermodynamic processes, principle of increase of entropy and its applications, Available Energy, Availability and Irreversibility- Second law efficiency.

MODULE 4

Casting:-Characteristics of sand - patterns- cores- -chapelets- simple problems- solidification of metals and Chvorinov's rule - Elements of gating system- risering -chills

Welding:-welding metallurgy-heat affected zone- grain size and hardness- stress relieving- joint quality -heat treatment of welded joints - weldability - destructive and non destructive tests of welded joints Thermit welding, friction welding - Resistance welding, Arc Welding, Oxyacetyline welding

Rolling:- principles - types of rolls and rolling mills - mechanics of flat rolling-Defects-vibration and chatter - flat rolling -miscellaneous rolling process

Forging: methods analysis, applications, die forging, defects in forging

MODULE 5

Introduction to kinematics and mechanisms - various mechanisms, kinematic diagrams, degree of freedom- Grashof's criterion, inversions, coupler curves mechanical advantage, transmission angle. straight line mechanisms exact, approximate. Displacement, velocity analysis– relative motion - relative velocity. Instantaneous centre -Kennedy's theorem.

Acceleration analysis- Relative acceleration - Coriolis acceleration - graphical and analytical methods.

Cams - classification of cam and followers - displacement diagrams, velocity and acceleration analysis of SHM, uniform velocity, uniform acceleration, cycloidal motion

Graphical cam profile synthesis, pressure angle.

MEL332	COMPUTER AIDED DESIGN & ANALYSIS LAB	CATEGORY	L	T	P	CREDITS
		PCC	0	0	3	2
Preamble:						
<ul style="list-style-type: none"> To introduce students to the basics and standards of engineering design and analysis related to machine components. To make students familiarize with different solid modelling and analysis soft wares To convey the principles and requirements of modelling and analysis of machine elements. To introduce the preparation of part modelling and assembly modelling of machineries To introduce standard CAD packages to perform Finite Element Analysis of machine parts 						
Prerequisite:						
EST 110 - Engineering Graphics						
MEL 201 - Computer Aided Machine Drawing						
Course Outcomes - At the end of the course students will be able to						
CO1	Gain working knowledge in Computer Aided Design and modelling procedures.					
CO2	Gain knowledge in creating solid machinery parts.					
CO3	Gain knowledge in assembling machine elements.					
CO4	Gain working knowledge in Finite Element Analysis.					
CO5	Solve simple structural, heat and fluid flow problems using standard software					

Mapping of course outcomes with program outcomes (Minimum requirements)

	PO1	PO2	PO3	PO4	PO5	PO6	PO7	PO8	PO9	PO10	PO11	PO12
CO1	3	-	-	-	-	-	-	-	-	2	-	-
CO2	3	-	1	-	-	-	-	-	-	3	-	-
CO3	3	3	-	-	-	-	-	-	2	2	-	-
CO4	3	1	3	-	-	-	-	1	2	3	-	-
CO5	3	3	2	-	-	-	-	2	3	3	-	-

Mark Distribution

Total Marks	CIE Marks	ESE marks	ESE duration
150	75	75	2.5 hours

Continuous Internal Evaluation (CIE) Pattern:

Attendance	15 marks
Regular class work/Modelling and Analysis/Lab Record and Class Performance	30 marks
Continuous Assessment Test (minimum two tests)	30 marks

Continuous Assessment test pattern

Bloom's Taxonomy	Continuous Assessment Tests	
	Test 1 - PART A MODELLING (marks)	Test 2 - PART B ANALYSIS (marks)
Remember	10	10
Understand	10	10
Apply	20	20
Analyse	15	15
Evaluate	20	20
Create	25	25

End semester examination pattern

End semester examination shall be conducted on modelling and analysis and based on complete syllabus. The following general guidelines should be maintained for the award of marks

- Part A Assembly Modelling – 35 marks
- Part B Analysis – 30 marks
- Viva Voce – 10 marks.

Conduct of University Practical Examinations

The Principals of the concerned Engineering Colleges with the help of the Chairmen/Chairperson will conduct the practical examination with the approval from the University and bonafide work / laboratory record, hall ticket, identity card issued by college are mandatory for appearing practical University examinations. No practical examination should be conducted without the presence of an external examiner appointed by the University.

References Books:

1. Daryl Logan, A First course in Finite Element Method, Thomson Learning, 2007
2. David V Hutton, Fundamentals of Finite Element Analysis, Tata McGraw Hill, 2003
3. Ibrahim Zeid, CAD/ CAM Theory and Practice, McGraw Hill, 2007
4. Mikell P. Groover and Emory W. Zimmer, CAD/ CAM – Computer aided design and manufacturing, Pearson Education, 1987
5. T. R. Chandrupatla and A. D. Belagundu, Introduction to Finite Elements in Engineering, Pearson Education, 2012

Experiment List (Minimum 12 exercises)

SL.NO	PART - A (Minimum 6 models)	COURSE OUTCOMES	HOURS
1	Creation of high end part models (minimum 2 models, Questions for examinations must not be taken from this portions)	CO1, CO2	6
2	Creating assembly models of Socket and spigot joint, Knuckle Joint, Rigid flange couplings, Bushed Pin flexible coupling, Plummer block, Single plate clutch and Cone friction clutch. Pipe joints, Screw jack, Tail stock etc. (minimum 4 models)	CO1, CO2, CO3	12
	PART – B (Minimum 6 problems)		
3	Structural analysis. (minimum 3 problems)	CO4, CO5	6
4	Thermal analysis. (minimum 2 problems)	CO4, CO5	3
5	Fluid flow analysis. (minimum 1 problem)	CO4, CO5	3

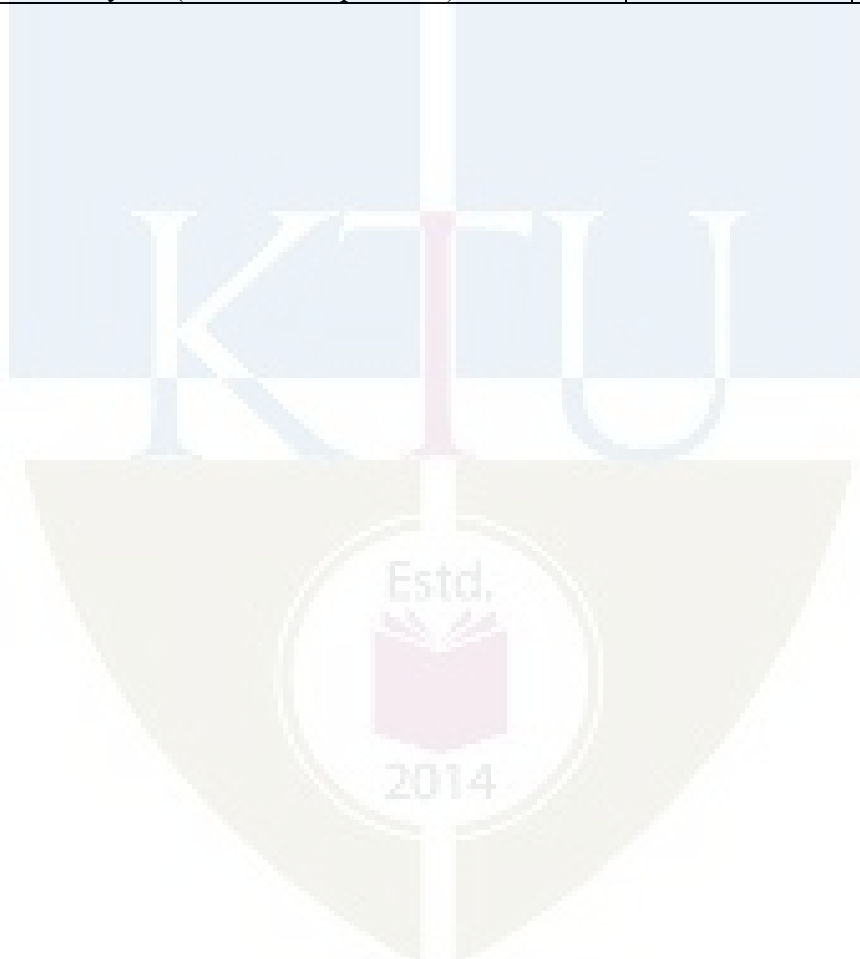

END SEMSTER EXAMINATION
MODEL QUESTION PAPER

MEL332: COMPUTER AIDED DESIGN AND ANALYSIS LAB

Duration : 2.5 hours

Marks : 75

Note :

1. All dimensions in mm
2. Assume missing dimensions appropriately
3. A4 size answer booklet shall be supplied
4. Viva Voce shall be conducted for 10 marks

PART A (ASSEMBLY MODELLING) – 35 marks

1. Create an assembly model using the part details given below

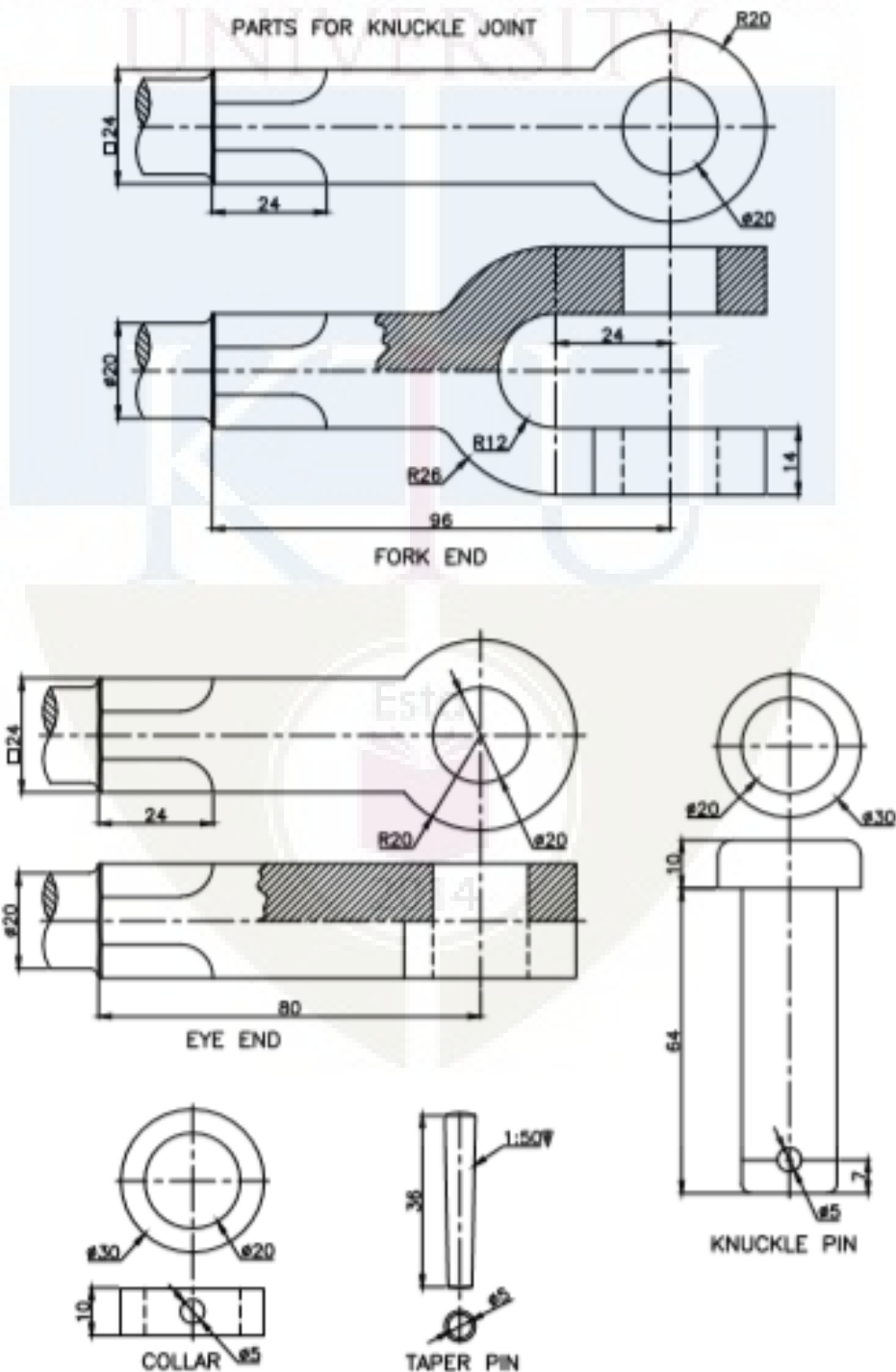

PART B (FINITE ELEMENT ANALYSIS) – 30 marks

2. Air flows over a long cylinder of 150mm diameter at a velocity of 3m/sec at a temperature of 105° F. Using this data and applying finite element technique find
 - a. Max velocity
 - b. Plot flow trajectories
 - c. Cut plot of velocity

APJ ABDUL KALAM
TECHNOLOGICAL
UNIVERSITY

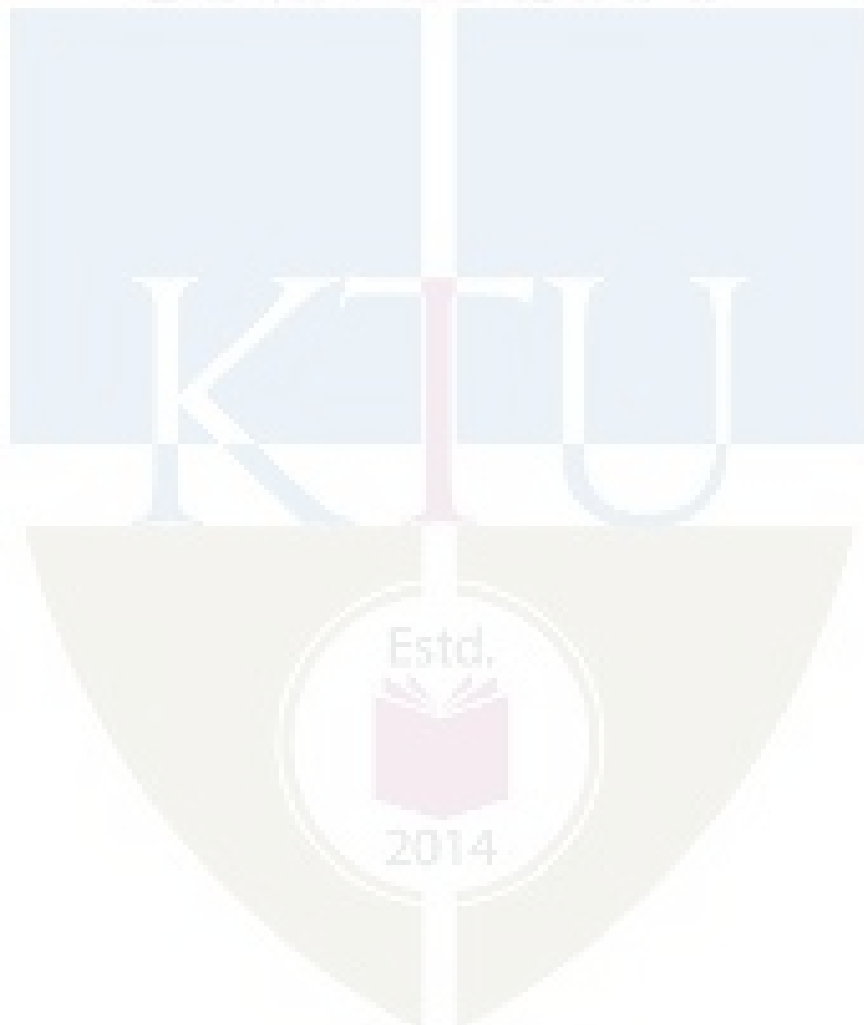

MEL334	THERMAL ENGINEERING LAB-II	CATEGORY	L	T	P	CREDIT
		PCC	0	0	3	2

Preamble: The course is intended to enable the students to get exposed to equipment related to heat and mass transfer. This includes understanding the working of equipments related to various heat transfer processes viz conduction, convection, radiation and mass transfer. These equipments are heat exchangers, refrigeration and air conditioning systems, compressor/blower and their applications in real life problems. Also the thermo physical properties of materials which are integral to these equipments will also be evaluated. Apart from this, calibration of various instruments which are essential to these equipments will be done.

Prerequisite: Should have undergone a course on Heat and Mass Transfer

Course Outcomes: After the completion of the course the student will be able to

CO 1	Evaluate thermal properties of materials in conduction, convection and radiation
CO 2	Analyse the performance of heat exchangers
CO 3	Illustrate the operational performances of refrigeration and air conditioning systems
CO 4	Perform calibration of thermocouples and pressure gauges

Mapping of course outcomes with program outcomes

	PO 1	PO 2	PO 3	PO 4	PO 5	PO 6	PO 7	PO 8	PO 9	PO 10	PO 11	PO 12
CO 1	3		2	3			2		3	2		2
CO 2	3		2	3			2		3	2		2
CO 3	3		2	3			2		3	2		2
CO 4	3		2	3			2		3	2		2

Assessment Pattern

Mark distribution

Total Marks	CIE	ESE	ESE Duration
150	75	75	2.5 hours

Continuous Internal Evaluation Pattern:

Attendance	:	15 marks
Continuous Assessment	:	30 marks
Internal Test (Immediately before the second series test)	:	30 marks

End Semester Examination Pattern: The following guidelines should be followed regarding award of marks

(a) Preliminary work	:	15 Marks
(b) Implementing the work/Conducting the experiment	:	10 Marks
(c) Performance, result and inference (usage of equipments and trouble shooting)	:	25 Marks
(d) Viva voce	:	20 marks
(e) Record	:	5 Marks

General instructions:

Practical examination is to be conducted immediately after the second series test covering entire syllabus given below. Evaluation is a serious process that is to be conducted under the equal responsibility of both the internal and external examiners. The number of candidates evaluated per day should not exceed 20. Students shall be allowed for the University examination only on submitting the duly certified record. The external examiner shall endorse the record.

Reference Books

1. Yunus A. Cengel, "Heat Transfer a Practical Approach", Tata McGraw-Hill Education, 4th Edition, 2012.
2. R. C. Sachdeva, "Fundamentals of Engineering, Heat and Mass Transfer", New Age publication, 3 rd Edition, 2012.
3. Holman J.P, "Heat transfer", Mc Graw-Hill, 10th. Ed., 2009
4. Frank P. Incropera and David P. Dewitt, Heat and Mass Transfer, John Wiley and sons, 2011
5. Kothandaraman, C.P., Fundamentals of Heat and Mass Transfer, New Age International, New Delhi, 2006

List of Exercises/Experiments: (Lab experiments may be given considering 12 sessions of 3 hours each. Minimum 12 experiments to be performed.)

1. Determination of LMTD and effectiveness of parallel flow, Counter flow and cross flow heat exchangers
2. Performance studies on a shell and tube heat exchanger
3. Development of heat transfer correlation for heat exchangers/condenser using modified Wilson Plot Method
4. Determination of heat transfer coefficients in free convection
5. Determination of heat transfer coefficients in forced convection
6. Determination of thermal conductivity of solids (composite wall/metal rod)
7. Determination of thermal conductivity of powder
8. Determination of thermal conductivity of liquids
9. Measurement of unsteady state conduction heat transfer
10. Determination of emissivity of a specimen
11. Determination of Stefan Boltzman constant
12. Measurement of solar radiation
13. Experimental study of dropwise and filmwise condensation
14. Experiments on boiling heat transfer
15. Study and performance test on refrigeration (Refrigeration Test rig)
16. Study and performance test on air conditioning equipment (Air Conditioning test rig)
17. Performance study on heat pipe
18. Calibration of Thermocouples
19. Calibration of Pressure gauge

