

ECT401	MICROWAVES AND ANTENNAS	CATEGORY	L	T	P	CREDIT
		PCC	2	1	0	3

Preamble: This course aims to impart knowledge on the basic parameters of antenna, design and working of various broad band antennas, arrays and its radiation patterns. It also introduces various microwave sources, their principle of operation and study of various microwave hybrid circuits and microwave semiconductor devices.

Prerequisite: ECT 302 ELECTROMAGNETICS

Course Out Comes: After the completion of the course the student will be able to:

CO1-K2	Understand the basic concept of antennas and its parameters.
CO2-K3	Analyze the far field pattern of Short dipole and Half wave dipole antenna.
CO3-K3	Design of various broad band antennas, arrays and its radiation patterns.
CO4-K2	Illustrate the principle of operation of cavity resonators and various microwave sources.
CO5-K2	Explain various microwave hybrid circuits and microwave semiconductor devices.

Mapping of course outcomes with program outcomes:

	PO1	PO2	PO3	PO4	PO5	PO6	PO7	PO8	PO9	PO10	PO11	PO12
CO1	3	3		1								2
CO2	3	3	3	1	2							2
CO3	3	3	3	1	3							2
CO4	3	3	2	1								2
CO5	3	3	2	1								2

Assessment Pattern:

Bloom's Category	Continuous Assessment Tests		End Semester Examination
	1	2	
Remember			
Understand K2	20	20	40
Apply K3	30	30	60
Analyse			
Evaluate			
Create			

Mark distribution:

Total Marks	CIE	ESE	ESE Duration
150	50	100	3 Hours

Continuous Internal Evaluation Pattern:

Attendance	: 10 marks
Continuous Assessment Test (2 numbers)	: 25 marks
Assignment/Quiz/Course project	: 15 marks

End Semester Examination Pattern**Maximum Marks: 100****Time: 3 hours**

End Semester Examination Pattern: There will be two parts; Part A and Part B. Part A contain 10 questions with 2 questions from each module, having 3 marks for each question. Students should answer all questions. Part B contains 2 questions from each module of which student should answer any one. Each question can have maximum 2 subdivisions and carry 14 marks.

Course Level Assessment Questions**Course Outcome 1 (CO1):**

- Define isotropic radiator and derive the expression for its electric field strength.
- Explain the terms
 - Antenna temperature
 - Antenna efficiency
 - Beam efficiency
 - Radiation pattern
 - Antenna Polarization
- Show that the directivity of a half wave dipole is 4 (from the expression for average power).
- Find the radiation intensity of a current element with corresponding field strength in the direction of maximum radiation of $E_m = \frac{60}{r\sqrt{80}} V/m$

Course Outcome 2 (CO2):

- Show that the directivity of a half wave dipole is 4 (from the expression for average power).
- Derive expressions for the Far Field components and Radiation Resistance and Directivity of a short dipole antenna.
- State and Prove Reciprocity Theorem.

Course Outcome 3 (CO3):

- Derive the relation for normalized electrical field in the case of 'n' isotropic array sources
 $E_n = (AF)_n$.
- Explain the working of a horn antenna. Write down the expression for gain, HPBW and BWFN.
- Design an Endfire Array and plot its radiation pattern.
- Design a LPDA with $\tau = 0.85$, $\sigma = 0.03$ for the frequency range 15-45 MHz.

Course Outcome 4 (CO4):

1. Determine the resonant frequency of an air filled rectangular cavity operating in the dominant mode with dimensions as, $a=4\text{cm}$, $b=5\text{cm}$ and $d=6\text{cm}$.
2. Derive power output and efficiency of a reflex klystron.
3. What is the significance of slow wave structures used in microwave circuits? Explain different slow wave structures with neat sketches.
4. With neat diagram explain the operation of a travelling wave tube.
5. With the help of figures explain the bunching process of an 8-cavity cylindrical magnetron.

Course Outcome 5 (CO5):

1. Explain S-parameters and its properties.
2. With a schematic describe the operation of a four port circulator. Obtain the simplified S matrix of a perfectly matched, lossless four port circulator.
3. Explain RWH theory of Gunn Oscillation.
4. Define Gunn Effect and with the help of figures explain different modes of operation of Gunn diode.

Syllabus

Module	Course contents	Hours
I	Basic antenna parameters: gain, directivity, beam width and effective aperture calculations, effective height, wave polarization, radiation resistance, radiation efficiency, antenna field zones. Duality and Principles of reciprocity, Helmholtz theorem (derivation required), Field, directivity and radiation resistance of a short dipole and half wave dipole (far field derivation).	7
II	Broad band antenna: Principle of Log periodic antenna array and design, Helical antenna: types and design. Design of Microstrip Rectangular Patch antennas and feeding methods. Principles of Horn, Parabolic dish antenna (expression for E, H and Gain without derivation), Mobile phone antenna – Inverted F antenna.	6
III	Arrays of point sources, field of two isotropic point sources, principle of pattern multiplication, linear arrays of 'n' isotropic point sources. Array factor, Grating lobes. Design of Broadside, End fire and Dolph Chebyshev arrays. Concept of Phase array.	8
IV	Microwaves: Introduction, advantages, Cavity Resonators- Derivation of resonance frequency of Rectangular cavity. Single cavity klystron- Reflex Klystron Oscillators: Derivation of Power output, efficiency and admittance. Magnetron oscillators: Cylindrical magnetron, Cyclotron angular frequency, Power output and efficiency. Travelling Wave Tube: Slow wave structures, Helix TWT, Amplification process, Derivation of convection current, axial electric field, wave modes and gain.	8

V	<p>Microwave Hybrid circuits: Scattering parameters, Waveguide Tees- Magic tees, Hybrid rings. Formulation of S-matrix. Directional couplers: Two hole directional couplers, S-matrix. Circulators and Isolators. Phase Shifter.</p> <p>Microwave Semiconductor Devices: Amplifiers using MESFET. Principle of Gunn diodes: Different modes, Principle of operation Gunn Diode Oscillators.</p>	6
---	---------------------------------------------------------------------------------------------------------------------------------------------------------------------------------------------------------------------------------------------------------------------------------------------------------------------------------------------------------------------------------------------------------------	---

Text Books:

1. Balanis, Antenna Theory and Design, 3/e, Wiley Publications.
2. John D. Krauss, Antennas for all Applications, 3/e, TMH.
3. K D Prasad, Antenna and Wave Propagation, Satyaprakash Publications
4. Samuel Y. Liao, Microwave Devices and Circuits, 3/e, Pearson Education, 2003.
5. Robert E. Collin, Foundation of Microwave Engineering, 2/e, Wiley India, 2012.

References:

1. Collin R.E, Antennas & Radio Wave Propagation, McGraw Hill. 1985.
2. Jordan E.C. & K. G. Balmain, Electromagnetic Waves & Radiating Systems, 2/e, PHI.
3. Raju G.S.N., Antenna and Wave Propagation, Pearson, 2013.
4. Sisir K.Das & Annapurna Das, Antenna and Wave Propagation, McGraw Hill, 2012
5. Thomas A. Milligan, Modern Antenna Design, IEEE PRESS, 2/e, Wiley Inter science.
6. Das, Microwave Engineering, 3/e, McGraw Hill Education India Education, 2014
7. David M. Pozar, Microwave Engineering, 4/e, Wiley India, 2012.

Course Contents and Lecture Schedule.

No	Topic	No.of Lectures
Module I		
1.1	Basic antenna parameters (all parameters and related simple problems), Relation between parameters (derivation required)	2
1.2	Principles of reciprocity (proof required), Duality. Concept of retarded potential	1
1.3	Helmholtz theorem (derivation required)	
1.4	Derivation of Field, directivity and radiation resistance of a short dipole	2
1.5	Derivation of Field, directivity and radiation resistance of a half wave dipole.	2
Module II		
2.1	Principle of Log periodic antenna array and design, Helical antenna: types and design	2
2.2	Design of Rectangular Patch antennas and feeding techniques	2
2.3	Principles of Horn, Parabolic dish antenna, (expression for E, H, G without derivation).	1
2.4	Mobile phone antenna – Inverted F antenna.	1
Module III		

3.1	Arrays of point sources, field of two isotropic point sources, principle of pattern multiplication	2
3.2	Linear arrays of 'n' isotropic point sources. Grating lobes. Array factor (derivation)	2
3.3	Design of Broadside, End fire and Dolph Chebyshev arrays.	3
3.4	Concept of Phase array.	1
Module IV		
4.1	Microwaves: Introduction, advantages, Cavity Resonators-Types, Derivation of resonance frequency of Rectangular cavity (problems required)	1
4.2	Single cavity klystron- Reflex Klystron Oscillators: Derivation of Power output, efficiency and admittance.(problems required)	2
4.3	Magnetron oscillators: Cylindrical magnetron, Cyclotron angular frequency, Power output and efficiency.(problems required)	2
4.4	Travelling Wave Tube: Slow wave structures, Helix TWT, Amplification process, Derivation of convection current, axialelectric field, wave modes and gain. (problems required)	3
Module V		
5.1	Microwave Hybrid circuits: Scattering parameters, Waveguide Tees- Magic tees, Hybrid rings. Formulation of S-matrix.	1
5.2	Directional couplers: Two hole directional couplers, S-matrix. Circulators and Isolators. Phase Shifter.	2
5.3	Microwave Semiconductor Devices: Amplifiers using MESFET.	1
5.4	Principle of Gunn diodes: Different modes, Principle of operation Gunn Diode Oscillators.	2

Simulation Assignments (ECT 401)

The following simulation assignments can be done with MATLAB/HFSS/CST Microwave Studio or any Open software.

- Simulation of radiation pattern of
 - a) Microstrip patch antenna
 - b) Arrays
 - c) Helical antenna

Model Question paper**APJ ABDUL KALAM TECHNOLOGICAL UNIVERSITY**

SEVENTH SEMESTER B. TECH DEGREE EXAMINATION

Course Code: ECT401**Course Name: MICROWAVES AND ANTENNAS**

Max. Marks:100

Duration: 3 Hours

PART A*(Answer All Questions)*

- 1 Derive an expression for aperture area of an antenna. (3)
- 2 (i) Obtain the radiation resistance of a thin dipole antenna of length $\lambda/15$. (3)
(ii) Find HPBW of an antenna which has a field given by:
 $E(\theta) = \cos^2 \theta$, for $0 \leq \theta \leq 90^\circ$.
- 3 Why Log Periodic antenna is called as Frequency Independent antenna, explain? (3)
- 4 Briefly explain about Inverted F antenna. (3)
- 5 Explain (i) Pattern Multiplication (ii) Grating lobes (3)
- 6 Demonstrate the working principle of Phase Arrays. (3)
- 7 Derive the resonant frequency of a rectangular cavity resonator. (3)
- 8 What are re-entrant cavities? Show that they support infinite number of resonant frequencies. (3)
- 9 Explain with figure a ferrite isolator can support only forward direction waves. (3)
- 10 Write a short note on Phase shifter. (3)

PART B*(Answer one question from each module. Each question carries 14 marks)***MODULE I**

- 11 a) Define the terms (i) Retarded potential (ii) Antenna field zones (4)
b) Derive expressions for the Far Field components and Radiation Resistance and Directivity of a short dipole antenna. (10)
- OR**
- 12a) State and prove Helmholtz theorem (7)
b) (i) Compute the radiation resistance, power radiated and efficiency of an antenna having total resistance of 50Ω and effective height of 69.96m and a current of 50A (rms) at 0.480MHz. (7)
(ii) Calculate the effective aperture of a short dipole antenna operating at 100 MHz.

MODULE II

- 13 a) Explain the working of a parabolic dish antenna. Write down the expression for gain, HPBW and BWFN. (6)
- b) Design a rectangular microstrip antenna using a dielectric substrate with dielectric constant of 2.2, $h = 0.1588$ cm so as to resonate at 10 GHz. (8)

OR

- 14 a) Explain the working of a Log periodic dipole array and explain its design steps. (7)
- b) Explain axial mode helical antenna. Write down the expression for gain, HPBW, BWFN and radiation resistance of axial mode helical antenna. (7)

MODULE III

- 15 Derive expression for array factor of N isotropic sources for end-fire array and also the expression for major lobe, minor lobes and Nulls of the array. (14)

OR

- 16 a) Explain Chebyshev array and write down the expression for array factor. (7)
- b) Design a Broadside Array and plot its radiation pattern. (7)

MODULE IV

- 17a) A reflex klystron operates under the following conditions: $V_0 = 500$ V, $R_{sh} = 10$ K Ω , $f_r = 8$ GHz, $L = 1$ mm, $e/m = 1.759 \times 10^{11}$ (MKS system) The tube is oscillating at f_r at the peak of the $n = 2$ or mode. Assume that the transit time through the gap and beam loading to be neglected. Determine: - (7)
- The value of the repeller voltage V_r .
 - The direct current necessary to give a microwave gap voltage of 200V.
 - The electronic efficiency under this condition.
- b) Assuming pi mode of oscillations explain how a magnetron can sustain its oscillations using the cross field. (7)

OR

- 18 a) Show that the axial electric field of TWT varies with convection current. (7)
- b) Explain the electronic admittance of the gap in the case of reflex klystron. With admittance diagram explain the condition required for oscillation in a reflex Klystron. (7)

MODULE V

- 19 a) Explain the working of a microwave amplifiers using MESFET (8)
- b) Explain the constructional features of two-hole directional coupler and derive the S Matrix. (6)

OR

- 20 a) Draw the J-E characteristics of Gunn diode and explain its operation. (10)
- b) Discuss the constructional features of magic tees and derive its S Matrix. Why are they called so? (4)

ECT413	OPTICAL FIBER COMMUNICATION	CATEGORY	L	T	P	CREDITS
		PEC	2	1	0	3

Preamble: This course aims to introduce the concepts of light transmission through optical fibers and introduce the working of optical components.

Prerequisite: Basic concepts of Solid State Devices

Course Outcomes: After the completion of the course the student will be able to

CO 1	Understand the working and classification of optical fibers in terms of propagation modes
CO 2	Solve problems of transmission characteristics and losses in optical fiber
CO 3	Explain the constructional features and the characteristics of optical sources and detectors
CO 4	Describe the operations of optical amplifiers
CO 5	Understand the concept of WDM, FSO and LiFi

Mapping of course outcomes with program outcomes

	PO 1	PO 2	PO 3	PO 4	PO 5	PO 6	PO 7	PO 8	PO 9	PO 10	PO 11	PO 12
CO 1	3	3	1									1
CO 2	3	3	2									1
CO 3	3	3	2									1
CO 4	3	3	1									1
CO 5	3	3	2									1

Assessment Pattern

Bloom's Category		Continuous Assessment Tests		End Semester Examination
		1	2	
Remember	K1	10	10	10
Understand	K2	30	30	60
Apply	K3	10	10	30
Analyse	K4			
Evaluate				
Create				

Mark distribution

Total Marks	CIE	ESE	ESE Duration
150	50	100	3 hours

Continuous Internal Evaluation Pattern:

Attendance	: 10marks
Continuous Assessment Test(2numbers)	: 25 marks
Assignment/Quiz/Course project	: 15marks

End Semester Examination Pattern: There will be two parts; Part A and Part B. Part A contain 10 questions with 2 questions from each module, having 3 marks for each question. Students should answer all questions. Part B contains 2 questions from each module of which student should answer any one. Each question can have maximum 2 sub-divisions and carry 14 marks.

Course Level Assessment Questions

Course Outcome 1 (CO1): Know the classification and working of optical fiber with different modes of signal propagation

1. Illustrate the types of optical fibers with refractive index profiles.
2. Define Photonic Crystal Fibers and list the types.
3. What is the necessity of cladding for an optical fiber?

Course Outcome 2 (CO2): Understand the transmission characteristics and losses in optical fiber

1. Describe the various attenuation losses incurred by light signal while transmitting through a fiber.
2. What is meant by group velocity dispersion?
3. An optical fiber has an attenuation coefficient of 0.5dB/km at 1310nm. Find the optical power at 25km if 500 μ W of optical power is launched into the fiber.

Course Outcome 3 (CO3): Describe the constructional features and the characteristics of optical sources and detectors

1. What is a heterojunction? How it increases the radiance and efficiency of LEDs?
2. Draw the basic block diagram of an optical receiver and explain.

Course Outcome 4 (CO4): Describe the performance of optical amplifiers

1. What are salient features of semiconductor optical amplifiers?
2. Explain the amplification mechanism with energy level diagram in an EDFA.

Course Outcome 5 (CO5): Know the concept of WDM, FSO and LiFi

1. What are the underlying principles of the WDM techniques?
2. Explain in detail diffraction gratings.
3. Write a note on optical Add / Drop multiplexers.

SYLLABUS

Module 1:

Optical fiber Communications: The general system, Advantages of optical fiber communication, Optical fiber waveguides: Ray theory transmission, Modes in planar guide, Phase and group velocity
Fibres: Types and refractive index profiles, Step index fibers, Graded index fibers, Single mode fibers, Cutoff wavelength, Mode field diameter, effective refractive index. Fibre materials, photonic crystal fibre, index guiding PCF, photonic band-gap fibres, fibre cables.

Module 2:

Transmission characteristics of optical fiber: Attenuation, Material absorption losses, Linear scattering losses, Nonlinear scattering losses, Fiber bend loss, Dispersion, Chromatic dispersion, Intermodal dispersion: Multimode step index fiber.

Optical Fiber Connectors: Fiber alignment and joint loss, Fiber splices, Fiber connectors, Fiber couplers.

Module 3:

Optical sources: LEDs and LDs, structures, characteristics, modulators using LEDs and LDs. coupling with fibres, noise in Laser diodes, Amplified Spontaneous Emission noise, effects of Laser diode noise in fibre communications

Optical detectors: Types and characteristics, structure and working of PIN and AP, noise in detectors, comparison of performance. Optical receivers, Ideal photo receiver and quantum limit of detection.

Module 4:

Optical Amplifiers: basic concept, applications, types, doped fibre amplifiers, EDFA, basic theory, structure and working, Semiconductor laser amplifier, Raman amplifiers, TDFA, amplifier configurations, performance comparison.

Module 5:

The WDM concept, WDM standards, WDM components, couplers, splitters, Add/ Drop multiplexers, gratings, tunable filters. Introduction to free space optics, LiFi technology and VLC. Optical Time Domain Reflectometer (OTDR) – fault detection length and refractive index measurements.

Text Books

1. Gerd Keiser, Optical Fiber Communications, 5/e, McGraw Hill, 2013.
2. Mishra and Ugale, Fibre optic Communication, Wiley, 2013.

Reference Books

1. Chakrabarthy, Optical Fibre Communication, McGraw Hill, 2015.
2. Hebbar, Optical fibre communication, Elsevier, 2014
3. John M Senior- Optical communications, 3/e, Pearson, 2009.
4. Joseph C. Palais, Fibre Optic Communications, 5/e Pearson, 2013.
5. Keiser, Optical Communication Essentials (SIE), 1/e McGraw Hill Education New Delhi, 2008.

Course Contents and Lecture Schedule

No	Topic	No. of Lectures
1	Optical fiber Communications	(8)
1.1	The general system, Advantages of optical fiber communication	1
1.2	Optical fiber waveguides: Ray theory transmission	1
1.3	Modes in planar guide, Phase and group velocity	1
1.4	Fibres: Types and refractive index profiles, Step index fibers, Graded index fibers, Single mode fibers	2
1.5	Cutoff wavelength, Mode field diameter, effective refractive index	1
1.6	Fibre materials, photonic crystal fibre, index guiding PCF, photonic band-gap fibres, fibre cables.	2
2	Transmission characteristics of optical fiber:	(7)
2.1	Attenuation, Material absorption losses	1
2.2	Linear scattering losses	1
2.3	Nonlinear scattering losses, Fiber bend loss	1
2.4	Dispersion, Chromatic dispersion, Intermodal dispersion: Multimode step index fiber	2
2.5	Optical Fiber Connectors: Fiber alignment and joint loss	1
2.6	Fiber splices, Fiber connectors, Fiber couplers	1
3	Optical sources and detectors:	(8)
3.1	LEDs and LDs, structures, characteristics, modulators using LEDs and LDs	2
3.2	coupling with fibres, noise in Laser diodes	1
3.3	Amplified Spontaneous Emission noise, effects of Laser diode noise in fibre communications	1
3.4	Optical detectors: Types and characteristics, structure and working of PIN and AP	2
3.5	noise in detectors, comparison of performance	1
3.6	Optical receivers, Ideal photo receiver and quantum limit of detection.	1
4	Optical Amplifiers:	(6)
4.1	basic concept, applications, types	1
4.2	doped fibre amplifiers, EDFA, basic theory, structure and working	2
4.3	Semiconductor laser amplifier	1
4.4	Raman amplifiers, TDFA	1
4.5	amplifier configurations, performance comparison	1
5	The WDM concept	(6)
5.1	WDM standards, WDM components	1
5.2	couplers, splitters, Add/ Drop multiplexers	1
5.3	gratings, tunable filters	1
5.4	Introduction to free space optics, LiFi technology and VLC	1

5.5	Optical Time Domain Reflectometer (OTDR) – fault detection length and refractive index measurements.	2
	Total	35

Model Question paper**APJ ABDUL KALAM TECHNOLOGICAL UNIVERSITY**

SEVENTH SEMESTER B.TECH DEGREE EXAMINATION, (Model Question Paper)

Course Code: ECT413**Program: Electronics and Communication Engineering****Course Name: Optical Fiber Communication**

Max.Marks: 100

Duration: 3Hours

PART- A

Answer ALL Questions. Each Carries 3 mark.

- | | |
|--------------------------------------------------------------------|----|
| 1. Define acceptance angle and critical angle. | K1 |
| 2. What is the necessity of cladding for an optical fiber? | K3 |
| 3. What is meant by group velocity dispersion? | K2 |
| 4. Explain intermodal dispersion? | K2 |
| 5. Differentiate between spontaneous and stimulated emission. | K1 |
| 6. Draw the three key transition process involved in LASER action. | K1 |
| 7. Compare EDFA and TDFA. | K2 |
| 8. What is the principle of Raman amplifiers? | K2 |
| 9. Define FSO concept. List the advantages. | K2 |
| 10. Write short note on LiFi technology. | K2 |

PART – B

Answer one question from each module; each question carries 14 marks.

Module – I

11. a)	With block diagram explain a general light wave system. What are the advantages of optical communication?	7	CO1	K2
11. b)	i) Define Photonic Crystal Fibers . ii) Consider an optical fiber of 50 μm diameter, core index $n_1 = 1.5$, and cladding index $n_2 = 1.49$ for operation at $\lambda = 1.31 \mu\text{m}$. How many modes does this fiber support?	7	CO1	K2
OR				
12.a)	Illustrate the types of optical fibers with refractive index profiles.	6	CO1	K2
12.b)	Explain the following : (i) Acceptance angle (ii) Numerical aperture	8	CO1	K2

	If for a given optical fiber the refractive index of cladding and core are 1.45 and 1.47 respectively, calculate the numerical aperture and angle of acceptance in air.			
--	-------------------------------------------------------------------------------------------------------------------------------------------------------------------------	--	--	--

Module – II

13. a)	Explain macro bending and micro bending losses with a neat diagram.	10	CO2	K2
13. b)	An optical fiber has an attenuation coefficient of 0.5dB/km at 1310nm. Find the optical power at 25km if 500 μ W of optical power is launched into the fiber.	4	CO2	K3
	OR			
14.a)	Describe the various attenuation losses incurred by light signal while transmitting through a fiber.	9	CO2	K2
14.b)	Given an optical fiber of 50 μ m diameter, core index of 1.5, and cladding index 1.49 for operation at $\lambda = 1.31 \mu$ m, What would be the pulse spread due to modal dispersion over a distance of 10 km?	5	CO2	K2

Module-III

15 a)	With neat sketch explain the working of pin photodiode and APD	10	CO3	K2
15 b)	What is meant by responsivity? How it is related to quantum efficiency?	4	CO3	K3
	OR			
16a	What is a heterojunction? How it increases the radiance and efficiency of LEDs?	7	CO3	K3
16b	Draw the basic block diagram of an optical receiver and explain.	7	CO3	K2

Module-IV

17 a)	Explain the amplification mechanism with energy level diagram in an EDFA.	8	CO4	K2
17 b)	Compare the performance of different optical amplifiers	6	CO4	K2
OR				
18 a)	Explain the working of semiconductor optical amplifiers. What are salient features of semiconductor optical amplifiers?	7	CO4	K2
18 b)	What are different amplifier configurations? Explain the basic working principle of optical amplifiers.	7	CO4	K2

Module-V

19 a)	With neat sketch explain WDM scheme.	7	CO5	K2
19 b)	Illustrate the working principle of diffraction gratings.	7	CO5	K2
OR				
20 a)	Explain with block diagram the working of optical add / drop multiplexer. Explain why it is required in optical communication system.	7	CO5	K2
20 b)	How does an OTDR works? Explain the fault detection and refractive index measurement.	7	CO5	K2

ECT423	COMPUTER NETWORKS	CATEGORY	L	T	P	CREDIT
		PEC	2	1	0	3

Preamble: The course aims to expose students to computer networks taking a top-down approach of viewing from the layer of user applications and zooming into link layer protocols. The principles of various protocols used in every layer are studied in detail. A brief introduction to mathematical modelling of queues with an application to a single example is included.

Prerequisite: MAT 204 Probability, Random Process and Numerical Methods

Course Outcomes: After the completion of the course the student will be able to

CO1 K2	Describe the protocols used in web and email applications.
CO2 K4	Analyse problems pertaining to reliable data transfer, flow control and congestion over a TCP network.
CO3 K3	Apply Dijkstra's algorithm and distance-vector algorithm in the context of routing over computer networks.
CO4 K4	Analyze the performance of collision avoidance algorithms in random access protocols such as ALOHA.
CO5 K4	Analyze the delay performance of an ARQ system using standard queueing models.

Mapping of course outcomes with program outcomes

	PO 1	PO 2	PO 3	PO 4	PO 5	PO 6	PO 7	PO 8	PO 9	PO 10	PO 11	PO 12
CO 1	3	3	3									2
CO 2	3	3	3									2
CO 3	3	3	3									2
CO 4	3	3	3									2
CO 5												

Assessment Pattern

Bloom's Category		Continuous Assessment Tests		End Semester Examination
		1	2	
Remember				
Understand	K2	10	10	30
Apply	K3	20	20	40
Analyse	K4	20	20	30
Evaluate				
Create				

Mark distribution

Total Marks	CIE	ESE	ESE Duration
150	50	100	3 hours

Continuous Internal Evaluation Pattern:

Attendance	: 10 marks
Continuous Assessment Test (2 numbers)	: 25 marks
Assignment/Quiz/Course project	: 15 marks

End Semester Examination Pattern: There will be two parts; Part A and Part B. Part A contain 10 questions with 2 questions from each module, having 3 marks for each question. Students should answer all questions. Part B contains 2 questions from each module of which student should answer any one. Each question can have maximum 2 sub-divisions and carry 14 marks. Mark patterns are as per the syllabus with 60 % for theory and 40% for logical/numerical problems, derivation and proof.

Course Level Assessment Questions

Course Outcome 1 (CO1): Describe the protocols used in web and email applications.

1. Describe the HTTP message format
2. Compare and contrast two application layer protocols SMTP and HTTP

Course Outcome 2 (CO2): Analyse problems pertaining to reliable data transfer, flow control and congestion over a TCP network.

1. Why is it that voice and video traffic is often sent over TCP rather than UDP in today's Internet?
2. Suppose two TCP connections are present over some bottleneck link of rate R bps. Both connections have a huge file to send (in the same direction over the bottleneck link). The transmissions of the files start at the same time. What transmission rate would TCP like to give to each of the connections?

Course Outcome 3 (CO3): Apply Dijkstra's algorithm and distance-vector algorithm in the context of routing over computer networks.

1. Consider the following network. Compute the shortest-path from the node D to all other nodes using Dijkstra's shortest path algorithm. (Numbers indicated shows the link costs).

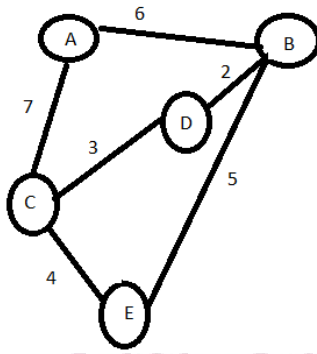

2. Consider a router that interconnects three subnets: Subnet 1, Subnet 2, and Subnet 3. Suppose all of the interfaces in each of these three subnets are required to have the prefix 223.1.17/24. Also suppose that Subnet 1 is required to support at least 60 interfaces, Subnet 2 is to support at least 90 interfaces, and Subnet 3 is to support at least 12 interfaces. Provide three network addresses (of the form a.b.c.d/x) that satisfy these constraints.

Course Outcome 4 (CO4):Analyze the performance of link-layer protocols in general, random access protocols in particular in terms of efficiency and collision avoidance capability.

1. Describe how slotted ALOHA achieves multiple access.
2. Distinguish between TDM, FDM and random access.

Course Outcome 5 (CO5):Analyze the delay performance of an ARQ system using standard queueing models.

1. Consider a network where packets arrive via N different nodes with different arrive rates. Illustrate the use of Little's law in this scenario to calculate the average packet delay inside the network.
2. Customers arrive in a restaurant at a rate of 5 per minute, and wait to receive their order for an average of 5 minutes. Customers eat in the restaurant with a probability of 0.5, and carry their order out without eating with probability 0.5. What is the average number of customers in the restaurant?

ELECTRONICS & COMMUNICATION ENGINEERING
SYLLABUS

Module	Course contents	Hours
I	<p>Components of computer networks Components of computer network, Applications of computer network – the Internet, Definition of protocol. Protocol standardization.</p> <p>Network edges, Network core and Network links Client and server hosts, connectionless and connection-oriented services provided to hosts, circuit-switched versus packet-switched network cores, FDM, TDM versus statistical multiplexing, Datagram versus Virtual-circuit networks. Access and physical media.</p> <p>Delay and loss in packet-switched networks Types of delay, Packet loss. Layered Architecture: Protocol layering, Internet protocol stack, Message encapsulation.</p> <p>Application Layer Communication between processes, Web application: HTTP, Message format, Email application: SMTP, Message format, MIME, POP3, IMAP and Web-based email. Domain Name System (DNS)</p>	8
II	<p>Transport Layer Multiplexing and demultiplexing: connectionless and connection-oriented. UDP. Protocols for reliable data transfer: ARQ protocols, stop-and-wait protocol, alternating-bit protocol, Go-back-N, Selective Repeat.</p> <p>TCP Connection, segment structure, RTT estimate, Flow control.</p> <p>Congestion Control General approaches. TCP congestion control.</p>	7
III	<p>Network Layer Datagram versus virtual-circuit network service, Router architecture, IPv4: datagram format, addressing, address assignment – manual and DHCP, NAT. ICMP. IPv6.</p> <p>Routing Algorithms Link-State (Dijkstra's) Algorithm, Distance-vector algorithm. Routing in Internet – RIP, OSPF, BGP. Broadcast and Multicast.</p>	7
IV	<p>Link Layer Services of link layer, Error detection and correction – checksum, CRC. Multiple access protocols – Channel partitioning, random access, taking-turns. ALOHA – pure and slotted, efficiency, CSMA, CSMA/CA, CSMA/CD. Link layer addressing: MAC address, ARP, DHCP. Ethernet. Link virtualization: ATM, MPLS</p>	7

V	Wireless Networks IEEE 802.11 wireless LAN Queueing models in computer networks Little's theorem and examples. Review of Poisson process. M/G/1 Queue. Delay analysis of Go-Back-N ARQ system.	8
---	---------------------------------------------------------------------------------------------------------------------------------------------------------------------------------------------------------------------	---

Text Books

1. James F. Kurose, Keith W. Ross, Computer Networking: A Top-Down Approach Featuring the Internet, 3rd edition, Pearson
2. D. Bertsekas, R.G. Gallager, Data Networks, Prentice Hall

Reference Books

1. Larry L. Peterson, Bruce S. Davie, Computer Networks – A Systems Approach, Morgan Kaufman
2. N. Abramson, F. Kuo, Computer Communication Networks, Prentice Hall
3. A. S. Tanenbaum, D. J. Wetherall, Computer Networks, Pearson
4. A. Kumar, D. Manjunath, J. Kuri, Communication Networking – An Analytical Approach, Morgan Kaufman Series.

Course content and Lecture plan

No	TOPIC	No of Lectures
MODULE 1		
1.1	Components of computer networks, Applications, Protocol, Protocol standardization	1
1.2	Hosts, connectionless and connection-oriented, circuit-switching versus packet-switching in network core design, FDM, TDM versus statistical multiplexing,	1
1.3	Datagram versus Virtual-circuit networks. Examples of access networks, and examples of physical media.	1
1.4	Types of delay, Packet loss.	1
1.5	Layered Architecture, Protocol layering, Internet protocol stack, Message encapsulation.	1
1.6	Communication between processes, HTTP, Message format	1
1.7	Email application: SMTP, Message format, MIME, POP3, IMAP and Web-based email.	1
1.8	Domain Name System (DNS)	1
MODULE II		
2.1	Services of transport layer, Multiplexing and demultiplexing. Connectionless and connection-oriented transport. UDP.	1
2.2	Protocols for reliable data transfer: ARQ protocols, stop-and-wait protocol, alternating-bit protocol, Go-back-N, Selective Repeat.	3

2.3	TCP Connection, TCP segment, RTT, Flow control.	1
2.4	Congestion, Congestion control. TCP congestion control.	2
MODULE III		
3.1	Services of Network Layer, Recap of Datagram versus virtual-circuit network service, Router.	1
3.2	IPv4 addressing, Address assignment – manual and DHCP, NAT. ICMP. IPv6.	2
3.3	Link-State (Dijkstra's) Algorithm, Distance-vector algorithm.	2
3.4	Routing in Internet – RIP, OSPF, BGP. Distinction between Broadcast and Multicast routing.	2
MODULE IV		
4.1	Services of link layer, Parity checks, checksum, CRC.	1
4.2	Multiple access protocols – Channel partitioning, random access, taking-turns.	1
4.3	ALOHA – pure and slotted, efficiency, CSMA, CSMA/CA, CSMA/CD.	2
4.4	Link layer addressing: MAC address, ARP, DHCP.	1
4.5	Ethernet	1
4.6	Link virtualization: ATM, MPLS	1
MODULE V		
5.1	IEEE 802.11 wireless LAN	1
5.2	Mathematical modeling of queues/buffers.	1
5.3	Little's theorem and examples.	2
5.4	Review of Poisson process. M/G/1 Queue	1
5.5	Delay analysis of Go-Back-N ARQ system.	3

Simulation Assignments

Assignment 1:

1. Understanding protocols using Wireshark.
2. Wireshark is a standard network packet analyzer tool which can be used to analyze how the different protocol layers work (by adding headers and other meta information) to an application layer message.
3. Students can download Wireshark for their OS from <https://www.wireshark.org/download.html>
4. Sample packet traces can be obtained from <https://wiki.wireshark.org/SampleCaptures> or <https://gitlab.com/wireshark/wireshark/-/wikis/SampleCaptures>. Examples such as TCP, DHCP, DNS can be viewed.
5. https://gaia.cs.umass.edu/kurose_ross/wireshark.php

Assignment 2: (requires Python/Matlab)

1. Programming/Implementation of Dijkstra's and distance vector algorithm for shortest path on a graph.
2. Representation of networks in a programming language – Students can use NetworkX library in Python for this.
3. Generation of random graphs (students can use inbuilt functions of NetworkX – see for example <https://networkx.org/documentation/stable/reference/generators.html>)
4. Visualization of the generated graphs can be done using <https://networkx.org/documentation/stable/reference/drawing.html>
5. Use inbuilt shortest path functions to obtain a baseline to test self-written code https://networkx.org/documentation/stable/reference/algorithms/shortest_paths.html)
6. Implementation of Dijkstra's algorithm (see https://en.wikipedia.org/wiki/Dijkstra%27s_algorithm)
7. Implementation of Bellman Ford's algorithm (https://en.wikipedia.org/wiki/Distance-vector_routing_protocol)
8. Compare your answers with that of the inbuilt functions.
9. Do the assignment following the instructions here: https://media.pearsoncmg.com/aw/aw_kurose_network_3/labs/lab6/lab6.html

Assignment 3: (understanding TCP)

1. Fully fledged simulation using NS3 can be given as a demonstration by the instructor https://www.cse.iitb.ac.in/~mythili/teaching/cs224m_autumn2017/tcpsimpa/index.html
2. Do the assignment following the instructions here: https://media.pearsoncmg.com/aw/aw_kurose_network_3/labs/lab5/lab5.html
3. Do the assignment following the instructions here: https://media.pearsoncmg.com/ph/esm/ecs_kurose_compnetwork_8/cw/#interactiveanimations
4. Do the assignment following the instructions here: https://media.pearsoncmg.com/ph/esm/ecs_kurose_compnetwork_8/cw/content/interactiveanimations/tcp-congestion/index.html

Assignment 4: (basic queueing model and Little's law)

1. Assignment 4 in the attached collection is a good to understand Little's law. https://drive.google.com/file/d/1CXauy0ehYno1ih6Zwllc_2XFLLe7cH6s/view

2. Do the assignment following the instructions here:

https://media.pearsoncmg.com/ph/esm/ecs_kurose_compnetwork_8/cw/content/interactiveanimations/queuing-loss-applet/index.html

Model Question paper

APJ ABDUL KALAM TECHNOLOGICAL UNIVERSITY

VII SEMESTER B. TECH DEGREE EXAMINATION, (Model Question Paper)

Course Code: ECT423

Course Name: COMPUTER NETWORKS

Max. Marks: 100

Duration: 3 Hours

PART A		
Answer all questions, each carries 3 marks		
1	Compare and contrast circuit switching and packet switching.	3
2	Explain the concept of FTTH internet access.	3
3	How does the process-to-process delivery service is achieved in transport layer?	3
4	Describe stop-and-wait protocol for reliable data transfer.	3
5	Give the basic blocks in router architecture.	3
6	What are the different error reporting messages in ICMP?	3
7	Explain the frame structure of Ethernet.	3
8	Compare and contrast different random-access protocols.	3
9	Customers arrive in a restaurant at a rate of 5 per minute, and wait to receive their order for an average of 5 minutes. Customers eat in the restaurant with a probability of 0.5, and carry their order out without eating with probability 0.5. What is the average number of customers in the restaurant?	3
10	Define M/G/1 queue.	3
PART B		
Answer any one full question from each module carries 14 marks.		
MODULE 1		
11(a)	How layered architecture helps in the efficient communication between hosts?	4
11(b)	Explain the functions performed by the layers in the internet protocol stack.	10
OR		

12(a)	Two hosts A and B separated by a distance of m meters, connected by a single link of rate R bps. The speed of propagation along the link is s m/s and host A is to send a packet of size L bits to host B. i) Express the propagation delay (Δ_{prop}) in terms of m and s . ii) Express the transmission delay (Δ_{trans}) in terms of L and R . iii) If $m=1000$ meters, $s=2.9 \times 10^8$ m/s, $L=100$ bits. Find the transmission rate of the link. (Assuming $\Delta_{prop} = \Delta_{trans}$)	8
12(b)	Describe any one of the mail access protocols.	6
MODULE II		
13(a)	Explain how TCP provides a flow control service to its applications.	5
13(b)	Compare and contrast TCP and UDP. Also explain the TCP segment structure.	9
OR		
14(a)	Host A and B are communicating over a TCP connection, and Host B has already received from A all bytes up through byte 248. Suppose Host A then sends two segments to Host B back-to-back. The first and second segments contain 40 and 60 bytes respectively. In the first segment, the sequence number is 249, the source port number is 503, and the destination port number is 80. Host B sends an acknowledgement whenever it receives a segment from Host A. i) In the second segment, sent from Host A to B, what are the sequence number, source port number, and destination port number? ii) If the second segment arrives before the first segment, in the acknowledgement of the first arriving segment. What is the acknowledgement number? iii) If the first segment arrives before the second segment, in the acknowledgement of the first arriving segment, what is the acknowledgement number, the source port number, and the destination port number?	7
14(b)	With the help of a neat diagram explain the operation of selective repeat ARQ.	7
MODULE III		
15(a)	Explain the datagram format in IPv4	7
15(b)	Describe the Internet's address assignment strategy using classless interdomain routing.	7
OR		
16(a)	Describe the process of assigning IP address to a host in an organization using DHCP protocol.	5
16(b)	Consider the following network. Compute the shortest-path from the node D to all other nodes using Dijkstra's shortest path algorithm. (Numbers indicated shows the link costs).	9

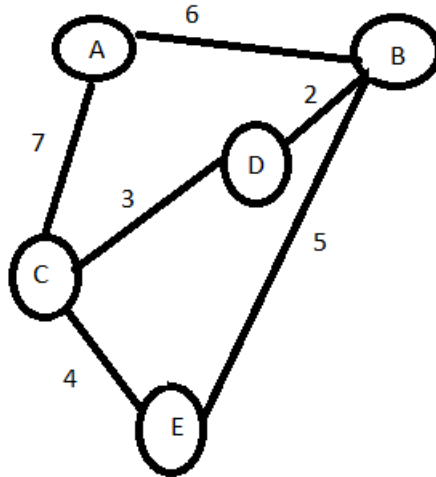
**MODULE IV**

17(a)	Explain the multiple access protocol used in IEEE 802.3.	7
17(b)	Explain the error detection mechanism using CRC with an example.	7
OR		
18(a)	Derive the efficiency of slotted ALOHA.	7
18(b)	Explain how the physical address of a host is being mapped from its IP address using address resolution protocol.	7
MODULE V		
19(a)	State and prove Little's theorem.	7
19(b)	Explain the IEEE 802.11 MAC protocol.	7
OR		
20(a)	Derive an expression for the average packet delay in a Go-Back-N ARQ system.	7
20(b)	Describe how a wireless station associates with an access point (AP) as per IEEE 802.11 protocol.	7

ECT433	OPTO-ELECTRONIC DEVICES	CATEGORY	L	T	P	CREDIT
		PEC	2	1	0	3

Preamble: This course aims to develop an insight over the working principles and performance parameters of various optoelectronics devices used for optical networks and communication.

Prerequisite: ECT 201 Solid State Devices

Course Outcomes: After the completion of the course the student will be able to

CO 1	Understand physics of optical processes in semiconductors.
CO 2	Distinguish different optical sources used in optoelectronic applications.
CO 3	Analyse different types of photodetectors based on their performance parameters
CO 4	Explain various optical modulators and optoelectronic devices.
CO 5	Explain various optical devices used for optical communication.

Mapping of course outcomes with program outcomes

	PO 1	PO 2	PO 3	PO 4	PO 5	PO 6	PO 7	PO 8	PO 9	PO 10	PO 11	PO 12
CO 1	3	3	2									
CO 2	3	3	3		1							
CO 3	3	3	3		1							
CO 4	3	3	2	2	2	2						
CO 5	3	3	2	2	2	2						

Assessment Pattern

Bloom's Category	Continuous Assessment Tests		End Semester Examination
	1	2	
Remember	10	10	20
Understand	30	30	60
Apply	10	10	20
Analyse			
Evaluate			
Create			

Mark distribution

Total Marks	CIE	ESE	ESE Duration
150	50	100	3 hours

Continuous Internal Evaluation Pattern:

Attendance	: 10 marks
Continuous Assessment Test (2 numbers)	: 25 marks
Assignment/Quiz/Course project	: 15 marks

End Semester Examination Pattern:

There will be two parts; Part A and Part B. Part A contain 10 questions with 2 questions from each module, having 3 marks for each question. Students should answer all questions. Part B contains 2 questions from each module of which student should answer any one. Each question can have maximum 2 sub-divisions and carry 14 marks.

Course Level Assessment Questions

Course Outcome 1 (CO1): Understand physics of optical processes in semiconductors.

1. Explain radiative and non radiative recombination
2. Describe Band to Band Recombination
3. Explain various Light Production mechanisms

Course Outcome 2 (CO2): Distinguish different optical sources used in optoelectronic applications

1. Explain the principle of operation of LED and LASER .
2. Explain DFB and DBR LASERS

Course Outcome 3 (CO3): Analyse different types of photodetectors based on their performance parameters

1. Describe the characteristics of APD
2. Explain the different type of Noise and its effect in the performance of Photodetectors

Course Outcome 4 (CO4): Explain various optical modulators and optoelectronic devices.

1. Explain the principle of operation of Electro-Optic Modulators and Acousto-Optic Modulators.
2. Explain different types of solar cells and its characteristics

Course Outcome 5 (CO5): Explain various optical devices used for optical communication.

1. Explain Fiber Bragg Grating and its refractive index profile.
2. Describe Optical Bistable Devices. Explain various methods for achieving optical bistability



SYLLABUS

Module 1 – Fundamentals of Semiconductor Optoelectronics

Optical processes in semiconductors: electron-hole generation and recombination, Absorption, Auger recombination, Heat generation and dissipation, Heat sources. Various light production mechanisms, Indirect band gap materials, Semiconductors used for optical Applications, Basic principle of LED and LASER, Spontaneous emission and Stimulated Emission, Coherence of sources.

Module 2 – Optical Sources

Construction and Operation of LEDs, Heterojunctions, Surface Emitter and Edge Emitter LEDs, Characteristics of LEDs, LASERS, Threshold Condition for lasing, Line Broadening Mechanisms, Fabry-Perot Lasers, Distributed Feedback (DFB) Lasers, Distributed Bragg Reflector (DBR) Lasers, Vertical Cavity Surface Emitting Lasers (VCSELs), In-Fibre Lasers.

Module 3 – Optical Detectors

Principle of Photo Detection, Working of LDR, PN diode, PIN diode, Avalanche Photodiode (APD), Characteristics of APD, Resonant Cavity Photo detector, Photo Transistor, Quantum efficiency, Responsivity, Noise in Photo detectors, Thermal Noise, Dark Current, Shot Noise, Quantum limit of Optical Detection.

Module 4 – Optoelectronic Devices and Modulators

Optoelectronic ICs, Advantages, Liquid Crystal Display, Structure, TFT display, Structure, Polymer LED, Organic LED, Optical Modulators using PN junction, Electro-Optic Modulators, Acousto-Optic Modulators, Raman-Nath Modulators, Optical switching and Logic devices, Optical Memory.

Solar Cells: basic working principle, VI Characteristics, Different types of solar cells, Dye sensitized solar cells (DSSC), Perovskite Solar cells.

Module 5 – Optical Devices in Optoelectronic Networks

Introduction to optical components, Splitters and Couplers, Directional Couplers, Fiber Bragg Gratings, Multiplexers, Attenuators, Isolators, Circulators, Fixed Filters, Tunable Filters, Add Drop Multiplexers, Waveguide Grating Routers, Optical Cross Connects, Wavelength Convertors, Optical Bistable Devices.

Text Book

1. Pallab Bhattacharya: Semiconductor Optoelectronic Devices, Pearson, 2009

References

1. Mark Csele, Fundamentals of Light Sources and Lasers, Wiley-Interscience, 2004
2. W.Koechner, M.Bass, Solid State Lasers, Springer, 2003
3. Yariv, Photonics Optical Electronics in modern communication, 6/e, Oxford University Press, 2006.
4. Harry J R Dutton, Understanding Optical Communications, IBM 1/e 1998
5. Alastair Buckley, Organic Light-Emitting Diodes, Woodhead, 2013
6. Stephen J Fonash, Solar Cell Device Physics, Elsevier 2/e, 2010

Course Contents and Lecture Schedule

No	Topic	No. of Lectures
1	Fundamentals of Semiconductor Optoelectronics	
1.1	Optical processes in semiconductors: electron-hole generation and recombination, Absorption.	1
1.2	Auger recombination, Heat generation and dissipation, Heat sources.	2
1.3	Various light production mechanisms	1
1.4	Indirect band gap materials, Semiconductors used for optical Applications	1
1.5	Basic principle of LED and LASER, Spontaneous emission and Stimulated Emission, Coherence of sources.	2
2	Optical Sources	
2.1	Construction and Operation of LEDs, Heterojunctios	1
2.2	Surface Emitter and Edge Emitter LEDs, Characteristics of LEDs	1
2.3	LASERs, Threshold Condition for lasing, Line Broadening Mechanisms	1
2.4	Fabry-Perot Lasers, Distributed Feedback(DFB) Lasers	1
2.5	Distributed Bragg Reflector (DBR) Lasers, Vertical Cavity Surface Emitting Lasers (VCSELs), In-Fibre Lasers.	2
3	Optical Detectors	
3.1	Principle of Photo Detection, Working of LDR, PN diode, PIN diode	1
3.2	Avalanche Photodiode (APD), Characteristics of APD	1
3.3	Resonant Cavity Photo detector, Photo Transistor	1
3.4	Quantum efficiency, Responsivity	1
3.5	Noise in Photo detectors, Thermal Noise, Dark Current, Shot Noise, Quantum limit of Optical Detection	2
4	Optoelectronic Devices and Modulators	
4.1	Optoelectronic ICs, Advantages	1
4.2	Liquid Crystal Display, Structure, TFT display, Structure	1
4.3	Polymer LED, Organic LED, Optical Modulators using PN junction	1
4.4	Electro-Optic Modulators, Acousto-Optic Modulators, Raman-Nath Modulators	2
4.5	Optical switching and Logic devices, Optical Memory	2
4.6	Solar Cells: basic working principle, VI Characteristics, Different types of solar cells	1
4.7	Dye sensitized solar cells (DSSC), Perovskite Solar cells	1
5	Optical Devices in Optoelectronic Networks	
5.1	Introduction to optical components, Splitters and Couplers,	1
5.2	Directional Couplers, Fiber Bragg Gratings, Multiplexers, Attenuators,	3

	Isolators, Circulators, Fixed Filters, Tunable Filters	
5.3	Add Drop Multiplexers, Waveguide Grating Routers, Optical Cross Connects	2
5.4	Wavelength Convertors, Optical Bistable Devices	1

Model Question Paper

APJ ABDUL KALAM TECHNOLOGICAL UNIVERSITY

MODEL QUESTION PAPER

ECT433 OPTO-ELECTRONIC DEVICES

Time: 3 hours

Max. Marks:100

PART A

Answer all questions. Each question carries 3 marks.

1. State the differences between Spontaneous emission and Stimulated emission.
2. Find the wavelength of light emitted by GaAs LED. Take band gap of GaAs to be 1.44eV at 300K
3. Explain surface emitter LED.
4. Explain any one line broadening mechanism in LASER Sources.
5. Calculate the photo current generated for an incident optical signal strength 600 nW on a PIN photodiode with responsivity 7.5 A/W
6. What is meant by dark current?
7. What is electro-optic effect?
8. Discuss the principle of optical memory.
9. List the different types of Wavelength division multiplexers and demultiplexers used of optical field access.
10. Explain the working principle of circulators.

PART B

MODULE - 1

- | | | |
|----|------------------------------------------------------------------|---|
| 11 | a Distinguish between radiative and non-radiative recombinations | 7 |
| | . | |
| | b Briefly explain what is meant by coherence of optical sources | 7 |
| | . | |
| OR | | |
| 12 | a Discuss the various light production mechanisms in materials | 7 |
| | . | |

- b Explain the basic principle of LED. 7

MODULE - 2

- 13 a With the help of a suitable diagram, explain the working principle of DFB Laser. 9

- b List the various features and characteristics of LEDs 5

OR

- 14 a With neat diagram, explain the principle of Surface Emitting LEDs and compare its features with edge emitting LEDs. 6

- b .A Light Emitting Diode gives $500\mu\text{w}$ output power when minority carrier lifetime is 4ns . Determine the output optical power when LED is modulated with 50MHz frequency with rms current equal to same dc current 8

MODULE - 3

- 15 a. Explain various noise mechanisms in optical detectors 5

- b. Discuss the construction and working principle of PIN photodiode. 9

OR

- 16 a. Elucidate different techniques commonly used for measuring high speed response of photodetectors 6

- b. Calculate the photocurrent density of a Si p-i-n photodiode with $8\ \mu\text{m}$ i-region when $0.87\ \mu\text{m}$ light power density $0.5\text{W}/\text{cm}^2$ is incident upon it. It is assumed the top illuminated surface is coated with anti-reflection coating. Given that absorption coefficient at $0.87\ \mu\text{m}$ is 600. 8

MODULE - 4

- 17 a. What is meant by acousto-optic effect? Explain Raman-Nath modulator. 9

- b. Explain the working principle of organic LEDs. 5

OR

- 18 a. Write a short note on Perovskite Solar cells 5

- b. Describe the structure of Polymer LED. List the advantages and disadvantages of Polymer LED. 9

MODULE - 5

- 19 a. Discuss the principle of tunable filters. 8

- b. Explain the principle and working of waveguide grating routers 6

OR

- 20 a. Explain different types of fixed optical filters. 9

- b. Calculate the physical grating period required for FBG for rejecting $980\ \text{nm}$ optical signals. Take average refractive index of the core = 1.45 5

ECT443	INSTRUMENTATION	CATEGORY	L	T	P	CREDIT
		PEC	2	1	0	3

Preamble: This course aims to introduce the basic concepts of electronic measuring instruments for measuring physical variables using transducers and to familiarize the concepts of the control systems PLC,DCS and SCADA.

Prerequisite: Nil

Course Outcomes: After the completion of the course the student will be able to

CO 1	Interpret the basic concepts of measuring instruments, its classification, and selection criteria, static and dynamic characteristics.
CO 2	Understand the principle, construction and working of transducers for measuring physical variables.
CO 3	Comprehend the principle, construction and working of various electronic measuring instruments.
CO 4	Explain the hardware architecture for PLC, DCS and SCADA.
CO 5	Apply PLC programming for selected industrial processes.

Mapping of course outcomes with program outcomes

	PO1	PO2	PO3	PO 4	PO 5	PO 6	PO 7	PO 8	PO 9	PO10	PO11	PO12
CO 1	3	3										
CO 2	3	3	3									
CO 3	3	3	3									
CO 4	3	3										
CO 5	3	3	3									

Assessment Pattern

Bloom's Category	Continuous Assessment Tests		End Semester Examination
	1	2	
Remember	10	10	20
Understand	30	20	50
Apply	10	20	30
Analyse			
Evaluate			
Create			

Mark distribution

Total Marks	CIE	ESE	ESE Duration
150	50	100	3 hours

Continuous Internal Evaluation Pattern:

Attendance	:	10marks
Continuous Assessment Test (2numbers)	:	25 marks
Assignment	:	15marks

End Semester Examination Pattern: There will be two parts; Part A and Part B. Part A contain 10 questions with 2 questions from each module, having 3 marks for each question. Students should answer all questions. Part B contains 2 questions from each module of which student should answer any one. Each question can have maximum 2 sub-divisions and carry 14 marks.

Course Level Assessment Questions**Course Outcome 1 (CO1):** Basics of measuring instruments

1. Explain the difference between accuracy and precision.
2. With neat block diagram explain the functional elements of a measuring instrument.
3. Explain the following static characteristics of a measuring instruments in details :- Sensitivity, Resolution, Selectivity, Linearity

Course Outcome 2 (CO2): Basics of transducers

1. Explain the working of a piezoelectric transducer.
2. Explain the principle of Hall Effect. How a proximity sensor works on the basis of Hall Effect?
3. Explain the construction, working principle, application, advantages and disadvantages of LVDT.

Course Outcome 3 (CO3): Basics of Electronics measuring instruments

1. With neat block diagram explain the working of a DSO
2. Explain ramp type digital voltmeter
3. With neat sketch explain the working of a frequency counter

Course Outcome 4 (CO4): Basics of PLC, DCS, SCADA

1. Explain the hardware components of a DCS
2. What are the various Input Output devices connected to a PLC?
3. Explain in details the SCADA architecture

Course Outcome 5 (CO5): PLC Programming

1. Two motors are to be controlled in a sequence. The second motor starts 30 seconds after the starting of first motor by a push switch. Develop a PLC ladder diagram for the following

cases and describe the circuit.

Case (A): Only one motor operates at a time.

Case (B): Both the motor gets off together after 50 seconds.

Syllabus

Module 1

Introduction to measuring instruments

Generalized Configurations and Functional elements of Instrumentation systems, Need for Measurement Systems, Classification of Types of Measuring instruments. Static and Dynamic characteristics of measuring instruments. Sensors and Transducers: - Need, Classification and selection criteria.

Module 2

Transducer

Principles of operation, construction, theory, advantages and disadvantages, applications of-

Resistive Transducers: Potentiometers, strain gauges, (metallic and semi-conductor type), Resistance Thermometer, Thermistors.

Inductive Transducers: LVDT (Linear variable differential transformer).

Capacitive Transducers: various capacitive transducers based upon familiar equation of capacitance (capacitive microphone)

Active Transducers: Thermocouple, Piezo-electric transducer, Hall Effect transducer, Flow meter

Module 3

Electronic Measuring Instruments

Digital storage oscilloscope, Working principle and applications of waveform analyser, digital frequency meter, harmonic distortion meter, harmonic analyser, spectrum analyser and logic state analyser IEEE - 488 General Purpose Interface Bus (GPIB) Instruments with application. EMI, Grounding and Shielding

Module 4

PLC, DCS and SCADA

PLC Basics: An Overall looks at PLCs, General PLC Programming Procedures, Devices to which PLC Inputs and Outputs are connected.

Distributed Control System: Meaning and necessity of distributed control; hardware components of DCS; DCS software.

Introduction to SCADA: SCADA overview, SCADA Architecture – Monolithic, Distributed and Networked, SCADA Protocols- IEC 60870-5-101, DNP-3, Profibus, Modbus

Module 5**PLC Programming**

Basic PLC Programming : Programming ON/OFF Inputs, Creating Ladder diagrams, Register Basics, PLC Timers and Counters, PLC Arithmetic functions, Number comparison functions, Data handling Functions: Skip function and applications; master control relay function and applications; jump with non-return and return; data table, register and other move functions, PLC functions with BITS.

Text Book

1. Ernest Doebelin, Dhanesh N. Manik, 'Doebelin's Measurement Systems', McGraw Hill, 7th Edition, 2019
2. Kalsi HS, "Electronic Instrumentation," Tata McGraw Hill, Third Edition
3. John R Hackworth, Frederick D Hackworth, Jr, "Programmable Logic controllers Programming Methods and Applications", Pearson Education.

Reference

1. Sawhney AK, "Electrical and Electronics Measurements and Instrumentation," Dhanpat Rai and Sons
2. John W Webb, Ronald A. Reis, "Programmable Logic Controllers- Principles and applications", PHI , ND, 2006

Course Contents and Lecture Schedule

No	Topic	No. of Lectures
1	Introduction to measuring instruments	
1.1	Generalised Configurations and Functional elements of Instrumentation systems	1
1.2	Need for Measurement Systems, Classification of Types of Measuring instruments, Static and Dynamic characteristics of measuring instruments	3
1.3	Sensors and Transducers: - Need, Classification and selection criteria.	1
2	Transducers	
2.1	Principles of operation, construction, theory, advantages and disadvantages, applications of- Resistive Transducers: Potentiometers, strain gauges, (metallic and semi-conductor type), Resistance Thermometer, Thermistors.	3
2.2	Principles of operation, construction, theory, advantages and disadvantages, applications of- Inductive Transducers: LVDT (Linear variable differential transformer).	2
2.3	Principles of operation, construction, theory, advantages and disadvantages, applications of- Capacitive Transducers: various Capacitive transducers based upon familiar equation of capacitance (capacitive microphone)	2

2.4	Principles of operation, construction, theory, advantages and disadvantages, applications of-, Active Transducers: Thermocouple, Piezo-electric transducer, Hall effect transducer, Flow meter	2
3 Electronic Measuring Instruments		
3.1	Digital storage oscilloscope:- Working, Applications	1
3.2	Working principle and applications of waveform analyzer, digital frequency meter, harmonic distortion meter, harmonic analyser, spectrum analyser and logic state analyser	3
3.3	IEEE - 488 General Purpose Interface Bus (GPIB) Instruments with application	1
3.4	EMI, Grounding and Shielding	1
4 PLC,DCS,SCADA		
4.1	PLC Basics: An Overall looks at PLCs, General PLC Programming Procedures, Devices to which PLC Inputs and Outputs are connected.	2
4.2	Distributed Control System: Meaning and necessity of distributed control; hardware components of DCS; DCS software	2
4.3	Introduction to SCADA: SCADA overview, SCADA Architecture – Monolithic, Distributed and Networked, SCADA Protocols- IEC 60870-5-101, DNP-3, Modbus, Profibus	2
5 PLC Programming		
5.1	Basic PLC Programming : Programming ON/OFF Inputs, Creating Ladder diagrams, Register Basics	2
5.2	PLC Timers and Counters, PLC Arithmetic functions, Data handling Functions: Skip function and applications	3
5.3	master control relay function and applications; jump with non-return and return;	2
5.4	Data table, register and other move functions, PLC functions with BITS	2

Model Question Paper

A P J ABDUL KALAM TECHNOLOGICAL UNIVERSITY
EIGHTH SEMESTER B TECH DEGREE EXAMINATION
BRANCH: ELECTRONICS AND COMMUNICATION
COURSE: ECT443 INSTRUMENTATION

Time:3 Hrs.

Max. Marks:100

PART A*Answer All Questions*

- | | | |
|----|-----------------------------------------------------------------------------------------------------|-----------|
| 1 | Explain the difference between accuracy and precision. | (3) K_2 |
| 2 | Compare transducer and sensor. | (3) K_2 |
| 3 | Explain the working of a piezoelectric transducer. | (3) K_2 |
| 4 | Differentiate between RTD and thermocouple. | (3) K_2 |
| 5 | Explain the need for grounding and shielding | (3) K_2 |
| 6 | What are the applications of a DSO? | (3) K_3 |
| 7 | What are the essential elements of a PLC system? | (3) K_2 |
| 8 | Explain any two applications of SCADA. | (3) K_2 |
| 9 | With suitable example explain latching in PLC Ladder logic | (3) K_3 |
| 10 | Draw the ladder diagram for the following logic functions.
(i) XOR (ii) NAND (iii) NOR | (3) K_3 |

PART B*Answer one question from each module. Each question carries 14 mark.***Module I**

- | | | |
|-------|------------------------------------------------------------------------------------|-----------|
| 11(A) | With neat block diagram explain the functional elements of a measuring instrument. | (8) K_2 |
| 11(B) | Explain the parameters for selection of a transducer. | (6) K_2 |

OR

- | | | |
|-------|--------------------------------------------------------------------------------------------------------------------------------------|-----------|
| 12(A) | Explain the following static characteristics of a measuring instruments in details:- Sensitivity, Resolution, Selectivity, Linearity | (8) K_2 |
| 12(B) | How are transducers classified? | (6) K_2 |

Module II

- | | | |
|-------|-------------------------------------------------------------------------------------------------|-----------|
| 13(A) | Derive the expression for finding gauge factor of a strain gauge | (8) K_3 |
| 13(B) | Explain the principle of Hall effect. How a proximity sensor works on the basis of Hall effect? | (6) K_2 |

OR

- 14 Explain the construction , working principle, application, advantages and disadvantages of LVDT (14) K_2

Module III

- 15(A) With neat block diagram explain the working of a DSO (7) K_2
 15(B) Explain the working principle of a frequency analyzer (7) K_2

OR

- 16(A) With neat sketch explain the working of a frequency counter (8) K_2
 16(B) Explain the working principle of a Logic State analyzer (6) K_2

Module IV

- 17(A) Explain the hardware components of a DCS (8) K_2
 17(B) What are the various Input Output devices connected to a PLC? (6) K_2

OR

- 18(A) Explain in details the SCADA architecture (8) K_2
 18(B) Differentiate between Profibus and Modbus (6) K_2

Module V

- 19 Two motors are to be controlled in a sequence. The second motor starts 30 seconds after the starting of first motor by a push switch. Develop a PLC ladder diagram for the following cases and describe the circuit. (14) K_3
 Case (A): Only one motor operates at a time.
 Case (B): Both the motor gets off together after 50 seconds.

OR

- 20 Saw, Fan and oil pump all go ON when a start button is pressed. (14) K_3
 If the saw has operated less than 20s, the oil pump should go off when the saw is turned off and the fan is to run for an additional 5s after the shutdown of the saw.

If the saw has operated for more than 20s, the fan should remain on until reset by a separate fan reset button and the oil pump should remain on for an additional 10 s after the saw is turned off. Write a program that will implement this process.

ECT453	ERROR CONTROL CODES	CATEGORY	L	T	P	CREDIT
		PEC	2	1	0	3

Preamble: This course aims to give an insight into the various codes used for error control in data transmission

Course Outcomes: On completion of the course the student will be able to

CO 1 K3	Describe the principles of block codes, types and their bounds
CO 2 K3	Illustrate the principles of cyclic codes and Galois Fields, encoding and decoding of binary BCH codes and algorithms for finding the error location polynomial
CO 3 K3	Demonstrate encoding, decoding and error location of Reed Solomon codes and Reed Muller codes
CO 4 K3	Illustrate the encoding and decoding of Convolution Codes and Turbo Codes
CO 5 K3	Describe the encoding, decoding and applications of LDPC Codes
CO 6 K3	Discuss the concepts of polar codes and its applications in 5G

Mapping of course outcomes with program outcomes

	PO 1	PO 2	PO 3	PO 4	PO 5	PO 6	PO 7	PO 8	PO 9	PO 10	PO 11	PO 12
CO 1	3	3	2									2
CO 2	3	3	2									2
CO 3	3	3	2									2
CO 4	3	3	2									2
CO 5	3	3	2									2
CO 6	3	3	2									2

Assessment Pattern

Bloom's Category		Continuous Assessment Tests		End Semester Examination
		1	2	
Remember	K1	10	10	10
Understand	K2	20	20	20
Apply	K3	20	20	70
Analyse				
Evaluate				
Create				

Mark distribution

Total Marks	CIE	ESE	ESE Duration
150	50	100	3 hours

Continuous Internal Evaluation Pattern:

Attendance : 10 marks

Continuous Assessment Test (2 numbers) : 25 marks

Assignment/Quiz/Course project : 15 marks

End Semester Examination Pattern: There will be two parts; Part A and Part B. Part A contain 10 questions with 2 questions from each module, having 3 marks for each question. Students should answer all questions. Part B contains 2 questions from each module of which student should answer any one. Each question can have maximum 2 sub-divisions and carry 14 marks.

Course Level Assessment Questions

Course Outcome 1 (CO1): Describe the principles of block codes, types and their bounds

1. Define Code Rate, Hamming Distance and Error detection and correction capabilities of Block codes
2. Construct Hamming Codes for a given Generator Matrix
3. State and prove Gilbert Varshamov bound

Course Outcome 2 (CO2): Illustrate the principles of cyclic codes and Galois Fields, encoding and decoding of binary BCH codes and algorithms for finding the error location polynomial

1. Design a (n,k) cyclic code in systematic form using a given generator polynomial $g(X)$
2. Determine all the conjugacy classes in an extended GF with respect to a given GF
3. Describe the Chien search algorithm for finding the error locator polynomial for Binary BCH Codes

Course Outcome 3 (CO3): Demonstrate encoding, decoding and error location of Reed Solomon codes and Reed Muller codes

1. Differentiate between the BCH and Vandermonde viewpoints of Reed Solomon Codes
2. Explain Sudan's algorithm for decoding RS codes
3. Devise an encoding circuit for RM $(1, m)$ code

Course Outcome 4 (CO4): Illustrate the encoding and decoding of Convolution Codes and Turbo Codes

1. Construct an encoder, state diagram and trellis for a convolution encoder using a given generator polynomial.
2. Decode convolution codes using Viterbi decoder
3. Construct a Turbo encoder for a given generator polynomial

Course Outcome 5 (CO5): Describe the encoding, decoding and applications of LDPC Codes

1. Determine if a given matrix satisfies the conditions of the parity check matrix of an LDPC code.
2. Construct the Tanner graph for a given LDPC code. Determine the girth of the Tanner graph
3. Discuss the message passing decoding over binary erasure channels

Course Outcome 6 (CO6): Discuss the encoding, decoding and applications in 5G of polar codes

1. Explain the basic ideas of polarization
2. Discuss polarization of BEC channels
3. Explain how polar codes can be applied in 5G

SYLLABUS

Error Control Codes

Module 1: Block Codes and Bounds.

Error Control Coding – Relevance of error control codes in Communication System, concepts of Code rate, Hamming Distance, Minimum Distance, Error detecting and correcting capability.

Repetition Codes, Hamming Codes, Review of Groups, Fields, Vector Spaces. Linear Block Codes - Generator matrix, Parity Check Matrix. Dual Codes, Error Detection and Correction over hard output channels. Dual of binary Hamming codes. Maximum Likelihood Decoding

Simple bounds on block codes - Singleton bound, Hamming Bound, Gilbert-Varshamov bound. Maximum-distance-separable (MDS) codes.

Module 2: Cyclic Codes

Review of basic concepts of cyclic codes – generator matrix, parity-check matrix. Polynomial view point. Encoding, systematic encoding, syndrome decoding.

Galois Fields -- Irreducible and Primitive Polynomials, Primitive elements, Field extension, Conjugate elements and Minimal Polynomials. Cyclotomic cosets.

BCH Codes - Design, BCH Bound, Decoding BCH codes – Decoding BCH – the general outline, computation of the syndrome, error locator polynomial, Chien Search algorithm,

Finding the error locator polynomial. Berlekamp Massey Algorithm. Burst-error correction capability of BCH codes.

Module 3: Reed-Solomon and Reed-Muller Codes

Reed Solomon Codes – BCH code viewpoint. Vandermonde matrix view point. MDS property. Generalized Reed-Solomon codes. Application of BCH decoding algorithms to Reed-Solomon decoding. Sudan's algorithm for decoding. Use of RS codes in disks and cloud storage.

Reed Muller Codes, Encoding and decoding of RM (1, m) codes. Majority-logic decoding of Reed-Muller codes.

Module 4: Convolutional and Turbo Codes

Convolution Codes, State Diagram, Systematic Encoders, Decoding of Convolution Codes – Viterbi algorithm, Turbo Codes, Encoding parallel concatenated codes.

Module 5: LDPC and Polar Codes

Low Density Parity Codes, Construction, Tanner Graphs, Message passing decoding. Example of message passing decoding over binary erasure channels. Message passing of LLR and decoding over AWGN channels.

Polar Codes – Introduction, polarization of BEC channels, Polar transform and frozen bits. LDPC and Polar codes in 5G.

Textbooks and References

1. Shu Lin, D. J Costello Jr. Error Control Coding: Fundamentals and Applications, Prentice Hall
2. Ron M Roth, Introduction to Coding Theory, Cambridge University Press
3. Todd K. Moon, Error Correction Coding: Mathematical Methods and Algorithms, Wiley.
4. T. Richardson, R. Urbanke, Modern Coding Theory, Cambridge University Press
5. H. Pfister, A Brief Introduction to Polar Codes, Lec. Notes
6. O. Gazi, Polar Codes: A Non-Trivial Approach to Channel Coding, Springer, 2018.
7. A. Thangaraj, LDPC and Polar Codes in 5G Standard, NPTEL Course

Course Contents and Lecture Schedule

S.No	Topic	No. of Lectures
1	Module 1: Block Codes and Bounds.	
1.1	Error Control Coding – Relevance of error control codes in Communication System, concepts of Code rate, Hamming Distance, Minimum Distance, Error detecting and correcting capability.	2
1.2	Repetition Codes, Hamming Codes, Review of Groups, Fields, Vector Spaces. Linear Block Codes - Generator matrix, Parity Check Matrix. Dual Codes, Error Detection and Correction over hard output channels. Dual of binary Hamming codes. Maximum Likelihood Decoding	2
1.3	Simple bounds on block codes - Singleton bound, Hamming Bound, Gilbert-Varshamov bound. Maximum-distance-separable (MDS) codes.	2
2	Module 2: Cyclic Codes	
2.1	Review of basic concepts of cyclic codes – generator matrix, parity-check matrix. Polynomial view point. Encoding, systematic encoding, syndrome decoding.	2
2.2	Galois Fields -- Irreducible and Primitive Polynomials, Primitive elements, Field extension, Conjugate elements and Minimal Polynomials. Cyclotomic cosets.	2
2.3	BCH Codes - Design, BCH Bound, Decoding BCH codes – Decoding BCH – the general outline, computation of the syndrome, error locator polynomial, Chien Search algorithm, Finding the error locator polynomial. Berlekamp Massey Algorithm. Burst-error correction capability of BCH codes.	4
3	Module 3: Reed-Solomon and Reed-Muller Codes	
3.1	Reed Solomon Codes – BCH code viewpoint. Vandermonde matrix view point. MDS property. Generalized Reed-Solomon codes. Application of BCH decoding algorithms to Reed-Solomon decoding. Sudan's algorithm for decoding. Use of RS codes in disks and cloud storage.	4
3.2	Reed Muller Codes, Encoding and decoding of RM (1, m) codes. Majority-logic decoding of Reed-Muller codes.	3
4	Module 4: Convolutional and Turbo Codes	
4.1	Convolution Codes, State Diagram, Systematic Encoders, Decoding of Convolution Codes – Viterbi algorithm	4
4.2	Turbo Codes, Encoding parallel concatenated codes.	3
5	Module 5: LDPC and Polar Codes	

5.1	Low Density Parity Codes, Construction, Tanner Graphs, Message passing decoding. Example of message passing decoding over binary erasure channels. Message passing of LLR and decoding over AWGN channels.	4
5.2	Polar Codes – Introduction, polarization of BEC channels, Polar transform and frozen bits. LDPC and Polar codes in 5G.	3

Simulation Assignments

Using GAP,

- Determine if a given polynomial is reducible
- Generate Hamming codes, Reed Muller Codes
- Generate the Standard Array of a given code C
- Generate the generator matrix of a given code C
- Generate the parity check matrix of a given code C
- Determine the Hamming Distance and minimum distance of a given code C

Similar exercises may be given



Model Question paper

APJ ABDUL KALAM TECHNOLOGICAL UNIVERSITY

SEVENTH SEMESTER B. TECH DEGREE EXAMINATION, (Model Question Paper)

Course Code: ECT453

Course Name: ERROR CONTROL CODES

Max. Marks: 100

Duration: 3 Hours

PART A

Answer ALL Questions. Each Carries 3 mark.

1	Generate all the code polynomials for the (7,4) Hamming Code generator polynomial $g(x) = 1+x+x^3$	K3
2	Define (a) MDS Code (b) Minimum Distance (c) Repetition Code	K1
3	Determine if x^5+x^3+1 is irreducible over GF (2)	K3
4	Illustrate the general outline for decoding BCH codes	K2
5	Prove that the minimum distance of an (n,k) RS code is n-k+1	K2
6	Construct the Generator matrix of a RM(1,3) code	K3
7	Describe a catastrophic encoder	K2
8	Discuss the applications of turbo codes in 5G	K2
9	Explain the method of construction of LDPC Codes	K2
10	Describe the applications of polar codes in 5G	K2
PART – B		
Answer one question from each module; each question carries 14 marks.		
Module - I		
11	Define and prove Hamming bound and Gilbert Varshamov bounds For the (7,4) Hamming code generator polynomial $g(x) = 1+x+x^3$, generate all possible code polynomials $c(x)$. Determine the parity check matrix $h(x)$ for this code. Calculate the minimum distance of the Hamming code generated	7
a.		CO1 K2
b.		7 CO1 K3
OR		
12	Consider a systematic block code whose parity check equations are: $p_1 = m_1+m_2+m_4$ $p_2 = m_1+m_3+m_4$ $p_3 = m_1+m_2+m_3$ $p_4 = m_2+m_3+m_4$ where m_i are the message digits and p_i are the check digits a) Find the generator matrix and parity check matrix for this code	14 CO1 K3

	b) How many errors can the code correct? c) Is the vector 10101010 a code word?	
	Module - II	
13 a	For a binary, narrow sense, triple error correcting BCH code of length 15, constructed using the polynomial x^4+x+1 (a) Compute a generator polynomial for this code (b) Determine the rate of the code (c) Construct the parity check matrix and generator matrix for this code	7 CO2 K3
b	Define and prove the BCH bound	7 CO2 K2
	OR	
14a	Construct the systematic encoder for cyclic codes and explain its working	7 CO2 K2
b	Describe the Chien search algorithm for BCH codes	7 CO2 K2
	Module - III	
15 a	Explain Sudan's algorithm for Reed Solomon Codes	7 CO3 K2
b	Differentiate between the BCH Viewpoint and Vandermondeviewpoints of Reed Solomon Codes	7 CO3 K2
	OR	
16	Form the generator matrix of the first order RM code RM (1,3) of length 8. What is the minimum distance of the code? Determine its parity check sums and devise a majority logic decoder for the code. Decode the received vector $r = (01000101)$	14 CO3 K3
	Module - IV	
17	For the $R=1/2$ convolution encoder with $G(x) = [1+x^2+x^3 \ 1+x+x^3]$ (a) Draw a hardware realization of the encoder (b) Determine the convolution generator matrix G (c) For the input sequence $m = [1,0,1,1,0,1,1]$ determine the coded output sequence (d) Draw the state diagram (e) Draw the trellis (f) Is this a catastrophic realization? Justify your answer	14 CO4 K2
	OR	
18 a.	Illustrate Turbo encoding without and with puncturing	7 CO4 K2
b.	Explain the Viterbi algorithm and the schematic of add compare select hardware	7

	implementation	CO4 K2
	Module - V	
19	<p>For the parity check matrix</p> $\begin{bmatrix} 1 & 1 & 0 & 1 & 0 & 0 & 0 \\ 0 & 1 & 1 & 0 & 1 & 0 & 0 \\ 0 & 0 & 1 & 1 & 0 & 1 & 0 \\ 0 & 0 & 0 & 1 & 1 & 0 & 1 \end{bmatrix}$ <p>a.</p> <p>(a) Construct the Tanner graph for the code (b) Determine the girth of the minimum girth cycle (c) Determine the number of cycles of length 6 (d) Determine a generator matrix for this code</p>	8 CO5 K3
b.	Explain message passing decoding of LDPC codes over binary erasure channels	6 CO5 K2
	OR	
20	a Describe the basic ideas of polarization	6 CO6 K2
b	Explain channel polarization for N=2 channel	8 CO6 K2

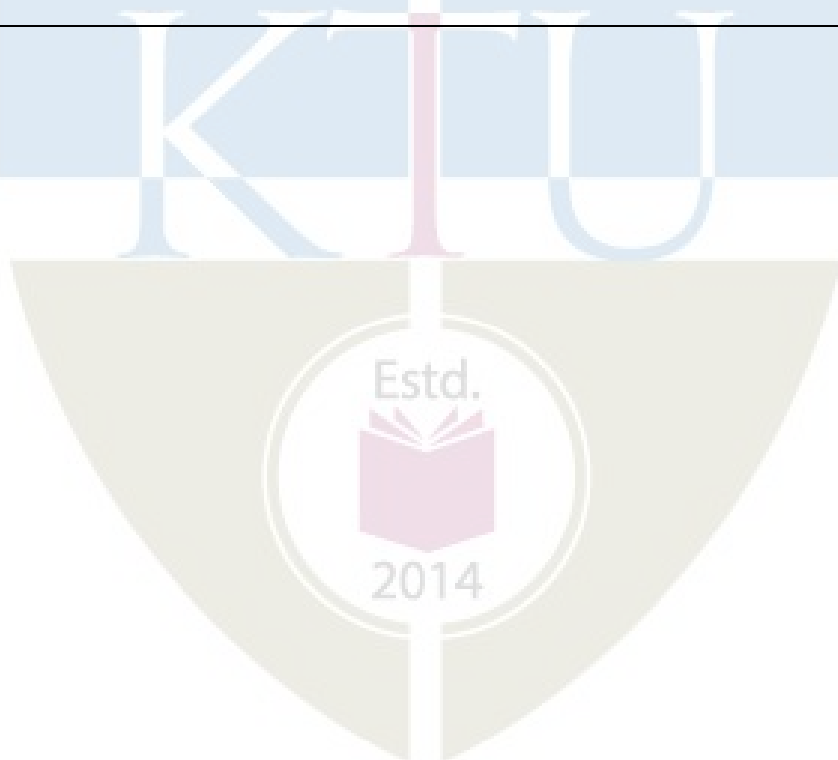

ECT463	MACHINE LEARNING	CATEGORY	L	T	P	CREDIT
		PEC	2	1	0	3

Preamble: This course aims to impart the fundamentals of machine learning techniques.

Prerequisite: MAT 101 Linear Algebra and Calculus

MAT 204 Probability, Random Process, and Numerical Methods

Course Outcomes: After the completion of the course the student will be able to

CO1 K2	Understand the basics of machine learning and different types.
CO2 K3	Differentiate regression and classification, apply Bayes' decision theory in classification
CO3 K3	Apply linear algebra and statistical methods in discriminant based algorithms
CO4 K2	Understand the basics of unsupervised learning and non-metric methods
CO5 K2	Understand ensemble methods, dimensionality reduction, evaluation, model selection.

Mapping of course outcomes with program outcomes

	PO1	PO 2	PO 3	PO 4	PO 5	PO 6	PO 7	PO 8	PO 9	PO1 0	PO11	PO12
CO 1	3											
CO 2	3	3	3	3	3							
CO 3	3	3	3	3	3							
CO 4	3											
CO 5	3			3	3							

Assessment Pattern

Bloom's Category		Continuous Assessment Tests		End Semester Examination
		1	2	
Remember				
Understand	K2	30	30	60
Apply	K3	20	20	40
Analyse				
Evaluate				
Create				

Mark distribution

Total Marks	CIE	ES E	ESE Duration
150	50	100	3 hours

Continuous Internal Evaluation Pattern:

Attendance	: 10 marks
Continuous Assessment Test (2 numbers)	: 25 marks
Assignment/Quiz/Course project	: 15 marks

End Semester Examination Pattern: There will be two parts; Part A and Part B. Part A contain 10 questions with 2 questions from each module, having 3 marks for each question. Students should answer all questions. Part B contains 2 questions from each module of which student should answer any one. Each question can have maximum 2 sub-divisions and carry 14 marks.

Course Level Assessment Questions

Course Outcome 1 (CO1): Understand the basics of machine learning and different types. (K2)

1. Differentiate supervised and unsupervised learning using examples.
2. Understand different terms and methods used in machine learning.

Course Outcome 2 (CO2): Differentiate regression and classification, apply Bayes' decision theory in classification (K3)

1. Differentiate regression and classification using examples
2. To apply Bayes' decision theory in classification for normal distributions

Course Outcome 3 (CO3): Apply linear algebra and statistical methods in discriminant based algorithms (K3)

1. Use statistical methods to obtain perceptron algorithm
2. Use support vector machines for separable classes and non separable classes

Course Outcome 4 (CO4): Understand the basics of unsupervised learning, ensemble methods and non-metric methods (K2)

1. Explain unsupervised learning with examples
2. Differentiate boosting and bagging.

3. Describe decision trees with examples.

Course Outcome 5 (CO5): Understand dimensionality reduction, evaluation and model selection techniques (K2)

1. Significance of dimensionality reduction.

2. Describe principal component analysis, Fischer's discriminant analysis.

3. Explain ROC curves, evaluation measures, validation set, bias-variance trade-off.

SYLLABUS

Module I

Basics of machine learning, supervised and unsupervised learning, examples, features, feature vector, training set, target vector, test set, feature extraction, over-fitting, curse of dimensionality. Review of probability theory, Gaussian distribution, decision theory.

Module II

Regression: linear regression, error functions in regression, multivariate regression, regression applications, bias and variance. Classification : Bayes' decision theory, discriminant functions and decision surfaces, Bayesian classification for normal distributions, classification applications.

Module III

Linear discriminant based algorithm: perceptron, gradient descent method, perceptron algorithm, support vector machines, separable classes, non-separable classes, multiclass case.

Module IV :

Unsupervised learning: Clustering, examples, criterion functions for clustering, proximity measures, algorithms for clustering. Ensemble methods: boosting, bagging. Basics of decision trees, random forest, examples.

Module V :

Dimensionality reduction: principal component analysis, Fischer's discriminant analysis. Evaluation and model Selection: ROC curves, evaluation measures, validation set, bias-variance trade-off. Confusion matrix, recall, precision, accuracy.

Text Books:

1. Bishop, C. M. "Pattern Recognition and Machine Learning" Springer, New York, 2006.
2. Theodoridis, S. and Koutroumbas, K. "Pattern Recognition". Academic Press, San Diego, 2003.

References:

1. Hastie, T., Tibshirani, R. and Friedman, J. "The Elements of Statistical Learning". Springer. 2001.
2. Duda, R.O., Hart, P.E., and Stork, D.G. "Pattern Classification". Wiley, New York, 2001.

Course Contents and Lecture Schedule

No	Topic	No. of Lectures
1	Module I	
1.1	Basics of machine learning, supervised and unsupervised learning, examples,	2
1.2	features, feature vector, training set, target vector, test set	2
1.3	feature extraction, over-fitting, curse of dimensionality.	1
1.4	Review of probability theory, Gaussian distribution, decision theory.	2
2	Module II	
2.1	Regression: linear regression, error functions in regression	2
2.2	multivariate regression, regression applications, bias and variance.	2
2.3	Classification : Bayes' decision theory,	1
2.4	discriminant functions and decision surfaces,	1
2.5	Bayesian classification for normal distributions, classification applications.	2
3	Module III	
3.1	Linear discriminant based algorithm: perceptron,	1
3.2	gradient descent method, perceptron algorithm,	2
3.3	support vector machines ,	1
3.4	SVM for separable classes and non-separable classes, multiclass case.	2
4	Module IV	
4.1	Unsupervised learning: Clustering, examples, criterion functions for	2

	clustering,	
4.2	proximity measures, algorithms for clustering.	2
4.3	Ensemble methods: boosting, bagging.	1
4.4	Basics of decision trees, random forest, examples.	2
5	Module V	
5.1	Dimensionality reduction: principal component analysis,	2
5.2	Fischer's discriminant analysis.	1
5.3	Evaluation and model selection: ROC curves, evaluation measures,	2
5.4	validation set, bias-variance trade-off.	1
5.5	confusion matrix, recall, precision, accuracy.	1

Simulation Assignments (using Python or Matlab)

- Working with Probability Distributions, Gaussian pdf generation
- Regression examples
- Classification examples
- Perceptron
- SVM
- Unsupervised learning techniques to find natural groupings and patterns in data
- Dimensionality reduction techniques



Model Question Paper

APJ ABDULKALAM TECHNOLOGICAL UNIVERSITY
MODEL QUESTION PAPER

ECT463 MACHINE LEARNING

Time: 3 hours

Max. Marks:100

PART A

Answer *all* questions. Each question carries *3 marks*.

1. Explain machine learning with examples.
2. Explain over-fitting in machine learning
3. Explain regression with examples
4. State Bayes decision theory
5. Draw a simple perceptron model
6. How SVM is used for multiclass problem?
7. Explain clustering with examples.
8. Explain decision trees with examples.
9. Explain ROC curves.
10. Explain bias-variance trade-off.

PART B

Answer *anyone* question from each module. Each question carries *14 marks*.

MODULE I

11. (a) Explain the terms features, training set, target vector, and test set (8 marks)
- (b) Distinguish supervised and unsupervised machine learning with examples. (6 marks)

OR

12. (a) Explain a multi-variate Gaussian distribution along with its parameters (6 marks)
- (b) Explain curse of dimensionality in machine learning? (8 marks)

MODULE II

13. (a) Differentiate regression and classification with examples (8 marks)
- (b) Explain bias and variance for regression (6 marks)

OR

14. (a) Obtain the decision surface for an equi-probable two class system, where the probability density functions of 1-dimensional feature vectors in both classes are normally distributed. (8 marks)
- (b) Show that the Bayesian classifier is optimal with respect to minimizing the classification error probability. (6 marks)

MODULE III

13. (a) Give a step by step description of the perceptron algorithm in classification. (8 marks)
(b) Explain the significance of gradient descent method in machine learning algorithms. (6 marks)

OR

14. (a) Obtain the cost function for optimization in SVM for separable classes. (8 marks)
(b) How SVM is used in non-separable classes? (6 marks)

MODULE IV

13. (a) Explain different criterion functions for clustering (8 marks)
(b) Give a description of different clustering algorithms (6 marks)

OR

14. (a) Explain different ensemble methods in classification. (8 marks)
(b) Illustrate random forest algorithm. (6 marks)

MODULE V

13. (a) Explain the significance of dimensionality reduction in machine learning. (6 marks)
(b) Describe Fisher Discriminant Analysis. (8 marks)

OR

14. (a) How performance evaluation and model selection is done in machine learning (8 marks)
(b) Explain confusion matrix, recall, precision, and accuracy. (6 marks)



ECT473	DSP ARCHITECTURES	CATEGORY	L	T	P	CREDIT
		PEC	2	1	0	3

Preamble: The aim of the course is to give an overview of the commonly used DSP algorithms, their applications and various techniques for the algorithmic and architecture level optimisations through various algorithm to architecture mapping which can lead to efficient hardware implementations. The course also introduces the basic features in Digital Signal Processors, DSP Architecture with case studies, the latest architectural trends in DSPs and their programming tools.

Prerequisite: ECT 303 Digital Signal Processing

Course Outcomes: After the completion of the course the student will be able to

CO 1	Identify the basic resource constraints in a practical DSP system and solve them using various techniques/transformations that map the DSP algorithms to efficient architectures.
CO 2	Illustrate various single core and multicore Digital Signal Processor architectures and identify the optimal processor for solving real life signal processing problems.
CO 3	Develop algorithms to solve signal processing problems using the latest hardware platforms and software tools.

Mapping of course outcomes with program outcomes

	PO 1	PO 2	PO 3	PO 4	PO 5	PO 6	PO 7	PO 8	PO 9	PO 10	PO 11	PO 12
CO 1	3	3	3	3								2
CO 2	3	3	3	3								2
CO 3	3	3	3	3	3			1	2	2	1	2

Assessment Pattern

Bloom's Category		Continuous Assessment Tests		End Semester Examination
		1	2	
Remember	K1	10	10	10
Understand	K2	20	10	20
Apply	K3	10	20	50
Analyse		10	10	20
Evaluate				
Create				

Mark distribution

Total Marks	CIE	ESE	ESE Duration
150	50	100	3 hours

Continuous Internal Evaluation Pattern:

Attendance	: 10 marks
Continuous Assessment Test (2 numbers)	: 25 marks
Assignment/Quiz/Course project	: 15 marks

End Semester Examination Pattern: There will be two parts; Part A and Part B. Part A contain 10 questions with 2 questions from each module, having 3 marks for each question. Students should answer all questions. Part B contains 2 questions from each module of which student should answer any one. Each question can have maximum 2 sub-divisions and carry 14 marks.

Course Level Assessment Questions

Course Outcome 1 (CO1): Identify the basic resource constraints in a practical DSP system and solve them using various techniques/transformations that map the DSP algorithms to efficient architectures.

1. Compare and contrast various DSP Algorithm representations
2. Demonstrate the algorithmic representation of typical DSP algorithms (Convolution, Various Filters, Transforms and filterbanks etc.) using Block Diagram, Signal Flow Graph, Data Flow Graph and Dependence Graph.
3. Explain the popular filter structures for efficient hardware implementations.
4. Define Loop bound, Iteration bound, critical path and explain their significance in the design of hardware systems.
5. Apply various algorithms to compute the iteration bound of a given Data Flow Graph (DFG).
6. Design efficient architectures for implementing DSP algorithms using pipelining, parallel processing, folding and unfolding techniques that meets various requirements such as low computational complexity, power and area.

Course Outcome 2 (CO2): Illustrate various single core and multicore Digital Signal Processor architectures and identify the optimal processor for solving real life signal processing problems.

1. Explain the basic architectural features of Digital Signal Processors
2. Explain the role of ILP in designing Digital Signal Processor architectures.
3. Compare and contrast Harvard and VLIW architectures of DSPs.

4. Explain the architecture of various single and multicore DSPs.
5. Give a brief description of the peripherals available for implementing DSP tasks in various single and multicore DSPs.

Course Outcome 3 (CO3): Develop algorithms to solve signal processing problems using the latest hardware platforms and software tools.

1. Explain various steps involved in implementing a signal processing task using CSS.
2. Explain the role of Open CL in the development of portable codes that take advantage of the parallel computing power of modern electronic hardwares,
3. Explain the role of Open MP Application Programming Interface (API) and Inter-Processor Communication (IPC) in implementing DSP applications in realtime.

SYLLABUS

Module 1: Basics of DSP Algorithm Representation to Architecture Mapping

DSP Algorithm representations –Block Diagram, Signal Flow Graph, Data Flow Graph, Dependence Graph;

Introduction to Filter structures- Recursive, Non-recursive and Lattice structures;

Fundamentals of DSP algorithm to architecture mapping - Loop bound, Iteration Bound, Critical Path, Algorithms for computing Iteration Bound – Longest Path Matrix Algorithm, Minimum Cycle Mean Algorithm.

Module 2: Transformations for Improved DSP Architectures

VLSI performance measures - area, power, and speed; Transformations for improved DSP architectures: Pipelining - Pipelining of FIR filters, Concept of Fine Grain Pipelining; Parallel Processing – Designing Parallel FIR systems, Pipelining and Parallel Processing for low power. Folding and Unfolding Transformations and its applications.

Module 3: Single Core DSP Architectures

Introduction to General Purpose Processors (GPP), Microcontroller Units (MCU), Digital Signal Processors (DSP) – comparison and Applications. The key features of a Digital Signal Processors – Dedicated hardware units, circular buffers, Modified bus structures and Memory access schemes. Introduction to Harvard, Super Harvard DSP architectures, Concept of Instruction Level Parallelism, VLIW Architecture and Single Instruction Multiple Data (SIMD) processor architecture.

Case Study: Introduction to a popular DSP from Texas Instruments, The TMS320C67xxSeries Processor - CPU Architecture - CPU Data Paths and Control - Timers - Internal Data/ Program Memory - External Memory Interface.

Module 4: Homogeneous Multicore DSPs

Introduction to multicore processors and their applications, A brief comparison between DSP SoCs, Field-Programmable Gate Arrays (FPGAs), Graphic Processors and CPUs.

Introduction to Multicore DSP Architectures: The TMS320C66x architecture: The CPU, Overview of the peripherals, Useful instructions, Overview of the memory organization.

Module 5: Programming the DSPs

Introduction to Code Composer Studio (CCS) software development tool and the TMS320C6678 EVM kit. Introduction to OpenMP Application Programming Interface (API) and Open Computing Language (OpenCL). Implementation of simple DSP algorithms – Dot Product.

Latest architectural trends in digital signal processing: Introduction to Heterogeneous Multicore DSP Architecture and FPGA SoCs.

Text Books

1. Keshab K. Parhi, "VLSI Signal Processing Systems, Design and Implementation", John Wiley & Sons, 1999
2. Naim Dahnoun, "Multicore DSP: from algorithms to real-time implementation on the TMS320C66x SoC". John Wiley & Sons, 2018.
3. Steven W. Smith, "The Scientist and Engineer's Guide to Digital Signal Processing" Second Edition, California Technical Publishing, 1999.
4. Reference Link for Overview of Latest Processor Architectures –
[Digital signal processors \(DSPs\) | Overview | Processors | TI.com,](https://training.ti.com/system/files/docs/c66x-corepac-instruction-set-reference-guide.pdf)
<https://training.ti.com/system/files/docs/c66x-corepac-instruction-set-reference-guide.pdf>

Reference Books

1. Rulph Chassaing, "Digital Signal Processing and Applications with the C6713 and C6416 DSK", John Wiley & Sons, 2005.
2. Sen M. Kuo, Woon-Seng S. Gan, Digital Signal Processors: Architectures, Implementations, and Applications, Prentice Hall, 2004.
3. Lars Wanhammar, DSP Integrated Circuits, Academic Press, 1999.
4. B Venkataramani, M Bhaskar, "Digital Signal Processors: Architecture, Programming and Applications", 2nd Ed., Tata McGraw-Hill Education, 2002.
5. A. Kharin, S. Vityazev and V. Vityazev, "Teaching multi-core DSP implementation on EVM C6678 board," 2017 25th European Signal Processing Conference (EUSIPCO), 2017, pp. 2359-2363, doi: 10.23919/EUSIPCO.2017.8081632

Course Contents and Lecture Schedule

No	Topic	No. of Lectures
1	Basics of DSP Algorithm Representation to Architecture Mapping	
1.1	DSP Algorithm representations –Block Diagram, Signal Flow Graph, Data Flow Graph, Dependence Graph.	2
1.2	Introduction to Filter structures- Recursive, Non-recursive and Lattice structures.	1
1.3	Fundamentals of DSP algorithm to architecture mapping - Loop bound, Iteration Bound, Critical Path,	2
1.4	Algorithms for computing Iteration Bound – Longest Path Matrix	2

	Algorithm, Minimum Cycle Mean Algorithm.	
2	Transformations for Improved DSP Architectures	
2.1	VLSI performance measures - area, power, and speed	1
2.2	Pipelining - Pipelining of FIR filters, Concept of Fine Grain Pipelining.	2
2.3	Parallel Processing – Designing Parallel FIR systems.	2
2.4	Pipelining and Parallel Processing for low power.	1
2.5	Folding and Unfolding Transformations and its applications.	3
3	Single Core DSP Architectures	
3.1	Introduction to General Purpose Processors (GPP), Microcontroller Units (MCU), Digital Signal Processors (DSP) - comparison and Applications.	1
3.2	The key features of a Digital Signal Processors – Dedicated hardware units, Circular Buffers, Modified bus structures and Memory access schemes.	1
3.3	Introduction to Harvard, Super Harvard DSP architectures, Concept of Instruction Level Parallelism, VLIW Architecture and Single Instruction Multiple Data (SIMD) processor architecture.	1
3.4	Case Study: Introduction to a popular DSP from Texas Instruments, The TMS320C67xx Series Processor- CPU Architecture - CPU Data Paths and Control - Timers – Multichannel Buffered Serial Ports (McBSPs)- Internal Data/ Program Memory - External Memory Interface.	4
4	Homogeneous Multicore DSPs	
4.1	Introduction to multicore processors and their applications, A brief comparison between DSP SoCs, Field-Programmable Gate Arrays (FPGAs), Graphic Processors and CPUs	1
4.2	Introduction to Multicore DSP Architectures: The TMS320C66x architecture: The CPU, Overview of the peripherals, Useful instructions, Overview of the memory organization.	5
5	Programming the DSPs	
5.1	Introduction to Code Composer Studio (CCS) software development tool and the TMS320C6678 EVM kit.	2
5.2	Introduction to Open MP Application Programming Interface (API) and Open Computing Language (OpenCL).	2
5.3	Implementation of simple DSP algorithms - Dot Product	1
5.4	Latest architectural trends in digital signal processing: Introduction to Heterogeneous Multicore DSP Architecture and FPGA SoCs.	1

Simulation Assignments/Course Projects:

1. Design an n-tap FIR filter. Apply pipelining to reduce the effective critical path. Simulate both using CCS and study the effect of pipelining.
2. Design an n-tap FIR filter. Construct a parallel FIR system. Simulate both using CCS and study the effect of parallel processing.
3. Consider a 6-tap FIR filter with data-broadcast structure. Apply folding using a folding factor of 2 on the structure. Implement both the filters and verify the functionality. Analyse the effect of folding.
4. Design a 4-bit bit-serial adder. Apply unfolding by 2 to make it a digit-serial adder. Implement both the filters and verify the functionality. Analyse and study the effect of unfolding.
5. Implement and realise the n-tap FIR filter utilising the multicore architecture of the TMS320C6678 processor. Implement and check the functionality by applying real time signals such as voice or recorded. Study the performance parameters.
6. Implement FFT algorithm using a single core on a TMS320C6678 processor. Extend it for the implementation of a 2-D FFT algorithm on an 8x8 data utilising the multicore architecture of the same processor. Study the performance parameters.
7. Study and implementation of a Real-Time Synthetic Aperture Radar (SAR) Algorithm Using TMS320C6678.
8. Design and implementation of a very large FFT algorithm using TMS320C6678 SoC.



Model Question paper**APJ ABDUL KALAM TECHNOLOGICAL UNIVERSITY**

SEVENTH SEMESTER B.TECH DEGREE EXAMINATION, (Model Question Paper)

Course Code: ECT473**Course Name: DSP ARCHITECTURES**

Max. Marks: 100 Duration: 3 Hours

PART A

Answer all Questions. Each Carries 3 mark.

1	Differentiate between Signal Flow Graph (SFG) and Data Flow Graph (DFG) with example.	K2
2	Define the terms Loop Bound and Iteration Bound. Explain the role of Iteration Bound in determining the speed of execution of a hardware.	K2
3	What is pipelining? Explain with an example, how it helps in reducing the critical path delay in implementing the DSP systems.	K2
4	What is Fine-Grain pipelining? Explain	K2
5	In what way the Super Harvard architecture based DSPs differs from the normal microprocessors?	K2
6	Explain with a suitable example, the role of circular buffers in implementing DSP algorithm.	K3
7	Compare and contrast DSP SoCs and FPGAs.	K2
8	Explain the CCS tools available for data visualisation.	K2
9	What is the concept of Heterogeneous Multicore DSP Architecture? Quote an example processor?	K1
10	Quoting a suitable example, explain the architectural advantages of an FPGA SoC.	K2
	PART – B Answer one question from each module; each question carries 14 marks.	
	Module - I	

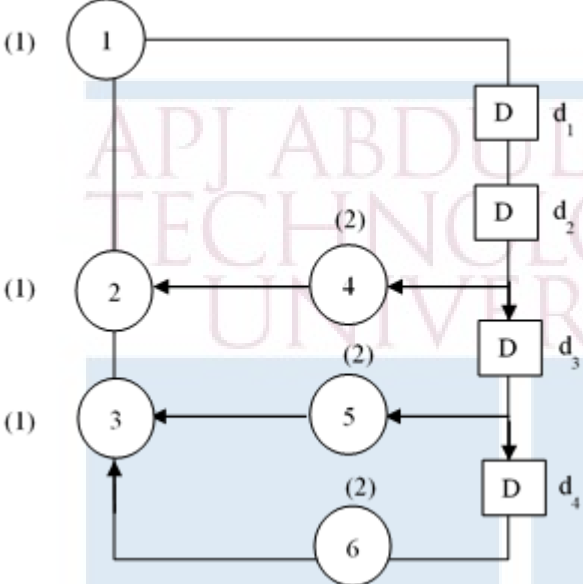
<p>11</p> <p>a.</p> <p>b.</p>	<p>Explain the Longest Path Matrix (LPM) Algorithm for computing the iteration bound of a DFG.</p> <p>For the DFG shown in figure below, the computation times of the nodes are shown in parentheses. Compute the iteration bound of this DFG using the LPM algorithm.</p> 	<p>7</p> <p>7</p> <p>CO1 K3</p>
<p>OR</p>		
<p>12</p> <p>a.</p> <p>b.</p>	<p>What are the advantages of lattice structure compared to other filter structures as far as implementation aspects are concerned.</p> <p>For the following transfer function given, Derive the basic lattice filter and draw its structure</p> $H(z) = \frac{3.9 + 2.3z^{-1} + z^{-2}}{1 + 0.3z^{-1} + 0.5z^{-2}}$ $H(z) = \frac{-3 + 5.192z^{-1} - 3.56z^{-2} + 2z^{-1}}{1 + 0.28z^{-1} + 0.056z^{-2} + 0.4z^{-3}}$	<p>14</p> <p>CO1 K3</p>
<p>Module - II</p>		
<p>13</p> <p>a.</p>	<p>Consider the non-recursive signal processing structure shown below.</p> <ol style="list-style-type: none"> Calculate the minimum sample period required to implement the algorithm using the given structure. Assume that TA and TM are the computation time required for addition and multiplication operations respectively. Find an equivalent implementation of this algorithm to improve the speed of the system using only 4 latches. Calculate the sample speed of the structure. How much improvement in sample speed is possible for the new structure if all the latches in the original structure (8 latches) are used? Is there any method for further improvements without adding any more 	<p>14</p> <p>CO1 K3</p>

registers? Explain.

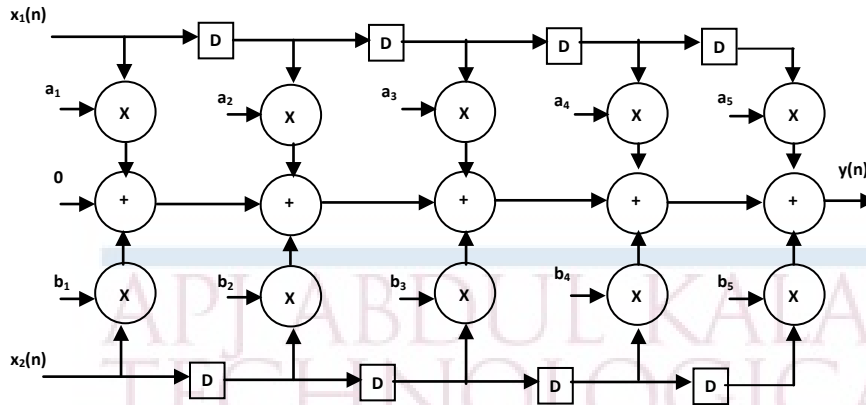

OR

14	<p>Consider a direct-form implementation of the FIR filter $y(n) = ax(n) + bx(n-2) + cx(n-3)$ Assume that the time required for 1 multiply-add operation is T</p> <ol style="list-style-type: none"> Pipeline this filter such that the clock period is approximately T Draw block filter architecture for a block size of three. Pipeline this block filter such that clock period is about T. What is the system sample 	14 CO1 K3
----	----------------------------------------------------------------------------------------------------------------------------------------------------------------------------------------------------------------------------------------------------------------------------------------------------------------------------------------------------------------------------------------------------------------------------------------------------------------------------------------	-----------------

Module - III

15	<p>The TMS320C6713 processor is used for an application where, it has to read the audio data inputted through the codec and has to send the data which is band limited to 1 KHz, to another external device for further processing. If the processor is connected to the audio codec through the McBSPs of the TMS320C6713 processor.</p> <ol style="list-style-type: none"> Draw the interconnection diagram showing all the necessary signals, for inputting an analog signal to the processor for the processing and to send the result there after, with the entire data transfer initiated through the McBSPs. What are the various registers need to be programmed in order to effect the data transfer. Explain the role and functionality of each. 	CO2 K3 6 8
----	------------------------------------------------------------------------------------------------------------------------------------------------------------------------------------------------------------------------------------------------------------------------------------------------------------------------------------------------------------------------------------------------------------------------------------------------------------------------------------------------------------------------------------------------------------------------------------------------------------------------------------------------------------------------------------------------------------------------------------------------------------------------------------	---------------------

OR

16	<p>a. Explain the role of a timer in a Digital Signal Processor with suitable examples. With reference to the Timer Control Register (Register fields given), explain the various facilities provided by the Timers in the TMS3206713 DSP processor.</p> <table border="1" style="width: 100%; text-align: center;"> <tr> <td style="width: 25%;">31</td> <td style="width: 25%;">12</td> <td style="width: 10%;">11</td> <td style="width: 10%;">10</td> <td style="width: 10%;">9</td> <td style="width: 10%;">8</td> </tr> <tr> <td colspan="2">Rsvd</td> <td>TSTAT</td> <td>INVINP</td> <td>CLKSRC</td> <td>C/P</td> </tr> </table> <table border="1" style="width: 100%; text-align: center;"> <tr> <td style="width: 10%;">7</td> <td style="width: 10%;">6</td> <td style="width: 10%;">5</td> <td style="width: 10%;">4</td> <td style="width: 10%;">3</td> <td style="width: 10%;">2</td> <td style="width: 10%;">1</td> <td style="width: 10%;">0</td> </tr> <tr> <td>HLD</td> <td>GO</td> <td>Rsvd</td> <td>PWID</td> <td>DATIN</td> <td>DATOUT</td> <td>INVOUT</td> <td>FUNC</td> </tr> </table> <p>b. The 6713 processor is used to control a device which is to be triggered every 5msec.</p>	31	12	11	10	9	8	Rsvd		TSTAT	INVINP	CLKSRC	C/P	7	6	5	4	3	2	1	0	HLD	GO	Rsvd	PWID	DATIN	DATOUT	INVOUT	FUNC	10 CO2 K3 5
31	12	11	10	9	8																									
Rsvd		TSTAT	INVINP	CLKSRC	C/P																									
7	6	5	4	3	2	1	0																							
HLD	GO	Rsvd	PWID	DATIN	DATOUT	INVOUT	FUNC																							

	If the Timer 0 peripheral of the processor is used for the purpose, what are the values to be loaded into the Timer 0 Period and Timer 0 Count registers to perform the required operation?	
	Module - IV	
17	Draw a neat block schematic of the architecture of TMS320C66x series of processor. Briefly explain the role of each block.	14 CO2 K3
	OR	
18	Give an overview of the memory organisation in TMS320C66xx series of processors. Explain the role of various memory controllers and interfaces in relieving the CPU load..	14 CO3 K2
	Module - V	
19	Explain the role of OpenMP Application Programming Interface and Open Computing Language (OpenCL) in implementing DSP applications that requires multithreading. Explain with reference to a case study project that you have implemented.	14 CO3 K2
	OR	
20	Give an overview of the latest architectural trends for implementing DSP algorithms. How will you compare FPGA SoCs and DSP SoCs?	14 CO3 K3



ECT415	MECHATRONICS	CATEGORY	L	T	P	CREDIT
		OEC	2	1	0	3

Preamble: This course introduces students to the rapidly emerging, multi-disciplinary, and exciting field of Mechatronics.

Prerequisite: Nil

Course Outcome: After the successful completion of the course the student will be able to :

CO1	Understand the working principles of various sensors and actuators in Mechatronics systems and be able to choose the suitable one for the real world application
CO2	Formulate and simulate models of mechatronics systems
CO3	Explain the implementation of PLC in mechatronics applications
CO4	Explain the standard fabrication techniques and principle of operation of MEMS devices
CO5	Design and Analysis of commonly encountered mechatronics systems for real time application

Mapping of course outcomes with program outcomes

	PO1	PO2	PO3	PO4	PO5	PO6	PO7	PO8	PO9	PO10	PO11	PO12
CO1	3	3										
CO2	3	3										
CO3	3	3	2									
CO4	3	3										
CO5	3	3										

Assessment Pattern

Bloom's Category	Continuous Assessment Tests		End Semester Examination
	1	2	
Remember	10	10	20
Understand	30	30	60
Apply	10	10	20
Analyse			
Evaluate			
Create			

Mark distribution

Total Marks	CIE	ESE	ESE Duration
150	50	100	3 hours

Continuous Internal Evaluation Pattern:

Attendance	: 10 marks
Continuous Assessment Test (2 numbers)	: 25 marks
Assignment/Quiz/Course project	: 15 marks

End Semester Examination Pattern: There will be two parts; Part A and Part B. Part A contain 10 questions with 2 questions from each module, having 3 marks for each question. Students should answer all questions. Part B contains 2 questions from each module of which student should answer any one. Each question can have maximum 2 sub-divisions and carry 14 marks.

Course Level Assessment Questions

Course Outcome 1 (CO1): Understand the working principles of various sensors and actuators in Mechatronics systems and be able to choose the suitable one for the real world application

1. Illustrate the working of a strain gauged load cell
2. Explain the working of any one non-contact temperature measurement system
3. Explain the principle of operation and suggest two applications of Hall effect sensor in mechatronic systems.
4. With neat sketches explain the working of a double acting hydraulic actuator.
5. Design a hydraulic circuit to operate a winch fitted with a hydraulic motor. The motor should be run clockwise, counter clockwise and stopped. Use a manually operated valve.
6. Explain any two situations when pneumatic actuators are preferred over hydraulic ones.

Course Outcome 2 (CO2): Formulate models of mechatronics systems

1. Derive the mathematical model of a general electrical system and draw its analogy with a mechanical system.
2. Explain the working of a mechanical device using closed loop control system with the help of a suitable example.

Course Outcome 3 (CO3): Explain the implementation of PLC in mechatronics applications

1. Explain 'latching' in PLC logic with an example.
2. Illustrate the significance of Internal Relays in PLC program
3. Consider a pneumatic system with single-solenoid controlled valves and involving two cylinders A and B, with limit switches a₋, a₊, b₋, b₊ detecting the limits of the piston rod movements. Design a ladder programme with the requirement being when the start switch is triggered, the sequence A₊, B₊, A₋,

10s time delay, B- occurs and stop at that point until the start switch is triggered again.

Course Outcome 4(CO4): Explain the standard fabrication techniques and principle of operation of MEMS devices

1. Explain the steps involved in photolithography. State the chemicals used in each of the stages along with the operating conditions.
2. Explain the criteria for choice of surface or bulk micromachining techniques in the design of micro systems.
3. Explain with block diagram the steps in LIGA process. State two advantages of LIGA process over other micro machining techniques.

Course Outcome 5 (CO5): Design and Analysis of commonly encountered mechatronics systems for real time applications

1. With the help of a neat sketch explain the different mechatronics modules used in automatic car park barrier system
2. Explain with a neat sketch the mechatronic implementation of a household weighing machine
3. With a neat sketch, explain the physical system and working of a pick and place robot.

SYLLABUS

MODULE I

Introduction to Mechatronics: Structure of Mechatronics system. Comparison between traditional and mechatronics approach. Sensors - Characteristics -Temperature, flow, pressure sensors. Displacement, position and proximity sensing by magnetic, optical, ultrasonic, inductive, capacitive and eddy current methods. Encoders: incremental and absolute. Resolvers and synchros. Piezoelectric sensors. Acoustic Emission sensors. vibration sensors. Force and tactile sensors. Range finders: ultrasonic and light based range finders

MODULE II

Actuators: Hydraulic and Pneumatic actuators - Directional control valves, pressure control valves, process control valves. Rotary actuators. Development of simple hydraulic and pneumatic circuits using standard Symbols. Electrical drives: DC, AC, brushless, servo and stepper motors. Harmonic drive. Magnetostrictive actuators and piezoelectric actuators.

MODULE III

System modeling - Mathematical models and basic building blocks of general mechanical, electrical, fluid and thermal systems. Typical elements of open and closed loop control systems. Adaptive controllers for machine tools.

Programmable Logic Controllers (PLC) –Basic structure, input/ output processing. Programming: Timers, Internal Relays, Counters and Shift registers. Development of simple ladder programs for specific purposes.

MODULE IV

Micro Electro Mechanical Systems (MEMS): Fabrication: Deposition, Lithography, Micromachining methods for MEMS -Surface and Bulk, Deep Reactive Ion Etching (DRIE) and LIGA processes. Principle, fabrication and working of MEMS based pressure sensor, accelerometer and gyroscope.

MODULE V

Mechatronics in Robotics- choice of Sensors and Actuators. Robotic vision system - Image acquisition: Vidicon, charge coupled device (CCD) and charge injection device (CID) cameras. Image processing techniques: histogram processing: sliding, stretching, equalization and thresholding.

Case studies of Mechatronics systems: Automatic camera, bar code reader, simple weighing machine, pick and place robot, automatic car park barrier system, automobile engine management system.

Text Books:

1. Bolton W., Mechatronics: Electronic Control Systems in Mechanical and Electrical Engineering, Person Education Limited, New Delhi, 2007
2. Ramachandran K. P., G. K. Vijayaraghavan, M. S. Balasundaram, Mechatronics: Integrated Mechanical Electronic Systems, Wiley India Pvt. Ltd., New Delhi, 2008.
3. Saeed B. Niku, Introduction to Robotics: Analysis, Systems, Applications, Person Education Inc., New Delhi, 2006.
4. Devdas Shetty, Richard A. Kolk, “Mechatronics System Design”, Thomson Learning Publishing Company, Vikas publishing house, Second edition, 2001.

Reference Books:

1. David G. Aldatore, Michael B. Histan, Introduction to Mechatronics and Measurement Systems, McGraw-Hill Inc., USA, 2003.
2. Gordon M. Mair, Industrial Robotics, Prentice Hall International, UK, 1998.
3. HMT, Mechatronics, Tata McGraw-Hill Publishing Company Ltd., New Delhi, 2004.
4. Vijay K. Varadan, K. J. Vinoy, S. Gopalakrishnan, Smart Material Systems and MEMS: Design and Development Methodologies, John Wiley & Sons Ltd., England, 2006.
5. Bishop, Robert H. The Mechatronics Handbook-2 Volume Set. CRC press, 2002.

Course Plan Course Contents and Lecture Schedule

Module No	Topic	No. of Lectures
1	Introduction to Mechatronics: Structure of Mechatronics system. Comparison between traditional and mechatronics approach	2
	Sensors - Characteristics -Temperature, flow, pressure sensors.	1
	Displacement, position and proximity sensing by magnetic, optical, ultrasonic, inductive, capacitive and eddy current methods	1
	Encoders: incremental and absolute. Resolvers and synchros.	1
	Piezoelectric sensors. Acoustic Emission sensors. vibration sensors, Force and tactile sensors	2
	Range finders: ultrasonic and light based range finders	1
2	Actuators: Hydraulic and Pneumatic actuators - Directional control valves	1
	pressure control valves, process control valves,	1
	Rotary actuators.	1
	Development of simple hydraulic and pneumatic circuits using standard Symbols.	1
	Electrical drives: DC, AC, and brushless, servo stepper motors	2
	Harmonic drive.	1
3	System modeling - Mathematical models and basic building blocks of general mechanical, electrical, fluid and thermal systems.	2
	Typical elements of open and closed loop control systems.	1
	Adaptive controllers for machine tools.	1
	Programmable Logic Controllers (PLC) –Basic structure, input/output processing.	1
	Programming: Timers, Internal Relays, Counters and Shift registers.	2
	Development of simple ladder programs for specific purposes	1
4	Micro Electro Mechanical Systems (MEMS): Fabrication: Deposition, Lithography	1
	Micromachining methods for MEMS -Surface and Bulk,	1
	Deep Reactive Ion Etching (DRIE) and LIGA processes.	1
	Principle, fabrication and working of MEMS based pressure sensor, accelerometer and gyroscope	2
	Mechatronics in Robotics- choice of Sensors and Actuators.	1
	Robotic vision system - Image acquisition: Vidicon, charge coupled device (CCD) and charge injection device (CID) cameras.	1
	Image processing techniques: histogram processing: sliding, stretching, equalization and thresholding.	2

5	Case studies of Mechatronics systems: Automatic camera, bar code reader, simple weighing machine, picks and place robot,	2
	automatic car park barrier system, automobile engine management system.	1
Total		35

Model Question Paper

**A P J ABDUL KALAM TECHNOLOGICAL UNIVERSITY
SEVENTH SEMESTER B TECH DEGREE EXAMINATION
COURSE: ECT415 MECHATRONICS
TIME: 3 HRS MAX. MARKS: 100**

PART A

Answer All Questions

- | | | |
|----|----------------------------------------------------------------------------------|---|
| 1 | Differentiate between absolute and incremental encoders | 3 |
| 2 | List six examples of temperature sensors | 3 |
| 3 | Explain how cushioning is achieved in pneumatic actuators with a sketch. | 3 |
| 4 | Mention any two differences between finite position and infinite position valves | 3 |
| 5 | List any 2 controlling factors in wet etching. | 3 |
| 6 | Sketch and label a MEMS based pressure sensor | 3 |
| 7 | What is latching? Draw a simple latched circuit | 3 |
| 8 | Write down the describing equations of basic mechanical building blocks | 3 |
| 9 | Illustrate the histogram processing technique for enhancing the image contrast | 3 |
| 10 | Bring out any 3 difference between CCD and CID camera. | 3 |

PART B

Answer one question from each module. Each question carries 14 marks.

Module I

11(A)	Explain the working of an optical absolute encoder. How the number of tracks and sectors of absolute encoder is related to the resolution of the encoder?	6	
11(B)	Explain the structure of a mechatronics system. How is it different from the traditional approach?	8	
OR			
12(A)	Explain the sensor characteristics to be considered when choosing a sensor for a mechatronics application	8	
12(B)	Compare the working of resolver and synchro	6	
Module II			
13(A)	Develop a pneumatic circuit with standard symbols, to operate two cylinders in sequence. Explain its working.	8	

13(B)	Explain the constructional features and working of brushless DC motor	6	
OR			
14(A)	Illustrate the working of Harmonic Drives with neat sketches	8	
14(B)	Design a hydraulic circuit to operate a winch fitted with a hydraulic motor. The motor should be run clockwise, counter clockwise and stopped. Use a manually operated valve.	6	
Module III			
15(A)	Draw and explain the block diagram of a feedback control system.	4	
15(B)	Develop a PLC ladder program for the following sequence: Start a motor with push switch, and then after a delay of 90s, start a pump. When the motor is switched off, the pump will get switched off after a delay of 5s. Mention the logic used for each rung in the program to substantiate your answer.	10	
OR			
16(A)	Explain how a PLC can be used to handle analog inputs?	4	
16(B)	Explain the model a fluid flow system with basic building blocks, clearly mention all assumptions	10	
Module IV			
17(A)	Explain the steps involved in photolithography. State the chemicals used in each of the stages along with the operating conditions	6	
17(B)	Compare and contrast various micro manufacturing techniques	8	
OR			
18(A)	Describe the various mechanical problems associated with surface micromachining	6	
18(B)	Explain the LIGA process associated with MEMS fabrication	8	
Module V			
19(A)	With the help of a neat sketch explain the different mechatronics modules used in automatic car park barrier system	10	
19(B)	List any four applications of robotic vision systems	4	
OR			
20(A)	Explain the working of Barcode reader with reference to the coding schemes. Mention the steps to process the digits in a barcode for a particular product. Develop the steps in a program for reading the barcode.	10	
20(B)	List the steps in thresholding technique in image processing	4	

ECT425	BIOMEDICAL INSTRUMENTATION	CATEGORY	L	T	P	CREDIT
		OEC	2	1	0	3

Preamble: This course aims to give a brief introduction to human physiology and various instrumentations system used for measurement and analysis of physiological parameters.

Prerequisite: Nil

Course Outcomes: After the completion of the course the student will be able to

CO 1	Explain the human anatomy and physiological signal Measurements.
CO 2	Illustrate various techniques used for measurement of Blood flow, blood pressure, and respiration rate and body temperature.
CO 3	Analyze the recording of ECG, EEG, EMG and ERG signals.
CO 4	Summarize the concept of assisting and therapeutic devices.
CO 5	Describe the advances in medical imaging techniques.

Mapping of course outcomes with program outcomes

	PO1	PO2	PO3	PO4	PO5	PO6	PO7	PO8	PO9	PO10	PO11	PO12
CO 1	3	3										
CO 2	3	3										
CO 3	3	3										
CO 4	3	3										
CO 5	3	3										

Assessment Pattern

Bloom's Category	Continuous Assessment Tests		End Semester Examination
	1	2	
Remember	10	10	20
Understand	30	30	60
Apply	10	10	20
Analyse			
Evaluate			
Create			

Mark distribution

Total Marks	CIE	ESE	ESE Duration
150	50	100	3 hours

Continuous Internal Evaluation Pattern:

Attendance	:	10marks
Continuous Assessment Test(2 numbers)	:	25 marks
Assignment	:	15marks

End Semester Examination Pattern: There will be two parts; Part A and Part B. Part A contain 10 questions with 2 questions from each module, having 3 marks for each question. Students should answer all questions. Part B contains 2 questions from each module of which student should answer any one. Each question can have maximum 2 sub-divisions and carry 14 marks.

Course Level Assessment Questions**Course Outcome 1 (CO1):Introduction to human physiological system**

1. Describe in detail the formation of resting potential and action potential in human body.
2. Briefly explain the physiological functions of human circulatory system
3. Briefly explain the physiological functions of human respiratory system

Course Outcome 2 (CO2):Bio potential electrodes and ECG

1. Describe different bio-potential electrode used to measure bioelectric events.
2. Explain in details the electro conduction system of a human heart. Illustrate the same with PQRST waveform of the ECG.

Course Outcome 3 (CO3):Measurement of blood pressure, blood flow and heart sound

1. With help of neat diagram explain how the oscilloetric method helps to measure blood pressure.
2. Write a short note on phonocardiography.

Course Outcome 4 (CO4):Measurement of EEG, EMG and Respiratory Parameters and therapeutic aid

1. Write a short note on tidal volume and vital capacity in breathing mechanism with neat diagram.
2. Explain heart lung machine with the help of neat diagram.
3. Explain spirometer for measurement of respiratory parameters
4. Explain standard 10-20 electrode placement system for EEG measurement.

Course Outcome 5 (CO5):Advances in Radiological Imaging andElectrical safety

1. Draw the block diagram and explain the principle of ultrasound imaging.
2. What are the biological effects of NMR imaging over CT?
3. What is the basic principle of CT? How image reconstruction is done in CT

Syllabus

Module 1

Introduction to human physiological system

Physiological systems of the body (brief discussion on Heart and cardio vascular system, Anatomy of nervous system, Physiology of respiratory systems) problems encountered in biomedical measurements. Sources of bioelectric potentials – resting and action potentials -propagation of action potentials – bio electric potentials example (ECG, EEG, EMG, ERG, EOG, EGG etc.)

Module 2

Bio potential electrodes and ECG

Bio potential electrodes – theory – microelectrodes – skin surface electrodes – needle electrodes – biochemical transducers – transducers for biomedical applications. Electro conduction system of the heart. Electro cardiograph – electrodes and leads – Einthoven triangle, ECG read out devices, ECG machine – block diagram.

Module 3

Measurement of blood pressure, blood flow and heart sound

Measurement of blood pressure – direct and indirect measurement – oscillometric measurement – ultrasonic method, measurement of blood flow and cardiac output, plethysmography – photo electric and impedance plethysmographs. Measurement of heart sounds – phonocardiography

Module 4

Measurement of EEG, EMG and Respiratory Parameters

Electro encephalogram – neuronal communication – EEG measurement, recording and analysis. Muscle response – Electromyogram (EMG) – Nerve Conduction velocity measurements – Electromyogram Measurements. Respiratory parameters – Spiro meter, pneumograph

Therapeutic Aid

Cardiac pacemakers – internal and external pacemakers, defibrillators. Ventilators, heart lung machine, hemodialysis, lithotripsy, infant incubators

Module 5

Advances in Radiological Imaging

X-rays- principles of generation, uses of X-rays- diagnostic still picture, fluoroscopy, angiography, endoscopy, and diathermy. Basic principle of computed tomography, magnetic resonance imaging system and nuclear medicine system – radiation therapy. Ultrasonic imaging system - introduction and basic principle.

Electrical safety

Electrical safety – physiological effects of electric current – shock hazards from electrical equipment – method of accident prevention, introduction to tele-medicine

Text Book

1. J. G. Webster, Medical Instrumentation, Application and Design, John Wiley and Sons

2. L. Cromwell, F. J. Weibell and L. A. Pfeiffer, Biomedical Instrumentation Measurements, Pearson education, Delhi, 1990.
3. R. S. Khandpur, Handbook of Biomedical Instrumentation, Tata Mc Graw Hill
4. J. J. Carr and J. M. Brown, Introduction to Biomedical Equipment Technology, Pearson Education

References:

1. John Enderele , Susan Blanchard, Joseph Bronzino, Introduction to Biomedical Engg, Academic Press
2. Welkowitz, Biomedical Instruments, Theory and Design, Elsevier
3. Jerry L Prince, Jonathan M Links, Medical Imaging Signals & Systems, Pearson Education

Course Contents and Lecture Schedule

No	Topic	No. of Lectures
1	Introduction to human physiological system	
1.1	Physiological systems of the body (brief discussion on Heart and cardiovascular system, Anatomy of nervous system, Physiology of respiratory systems) problems encountered in biomedical measurements.	3
1.2	Sources of bioelectric potentials – resting and action potentials	1
1.3	Propagation of action potentials – bio electric potentials example (ECG, EEG, EMG, ERG, EOG, EGG etc.)	2
2	Bio potential electrodes and ECG	
2.1	Bio potential electrodes – basic theory – microelectrodes – skin surface electrodes – needle electrodes	2
2.2	Biochemical transducers – transducers for biomedical applications	1
2.3	Instrumentation for clinical laboratory: Bio Potential amplifiers – instrumentation amplifiers, isolation amplifiers, chopper amplifier	2
2.4	Electro conduction system of the heart, Electro cardiograph – electrodes and leads – Einthoven triangle,	2
2.5	ECG read out devices, ECG machine – block diagram.	1
3	Measurement of blood pressure, blood flow and heart sound	
3.1	Measurement of blood pressure – direct and indirect measurement – oscillometric measurement – ultrasonic method	2
3.2	Measurement of blood flow and cardiac output, plethysmography – photo electric and impedance plethysmographs	2
3.3	Measurement of heart sounds – phonocardiography	1
4	Measurement of EEG, EMG and Respiratory Parameters, Therapeutic Aid	
4.1	Electro encephalogram – neuronal communication – EEG measurement,	2

	recording and analysis	
4.2	Muscle response– Electromyogram (EMG) – NerveConduction velocity measurements- Electromyogram Measurements.	2
4.3	Respiratory parameters – Spiro meter,pneumograph	1
4.4	Cardiac pacemakers – internal and external pacemakers,defibrillators.	1
4.5	Ventilators, heart lung machine, hemodialysis, lithotripsy, infantincubators	3
5	Advances in Radiological Imaging and Electrical Safety	
5.1	X-rays- principles of generation, uses of X-rays- diagnostic stillpicture, fluoroscopy, angiography, endoscopy, diathermy	2
5.2	Basic principle of computed tomography, magnetic resonanceimaging system and nuclear medicine system	3
5.3	Ultrasonic imaging system - introduction and basic principle	1
5.4	Electrical safety– physiological effects of electric current –shock hazards from electrical equipment –method of accident prevention, introduction to tele- medicine	2

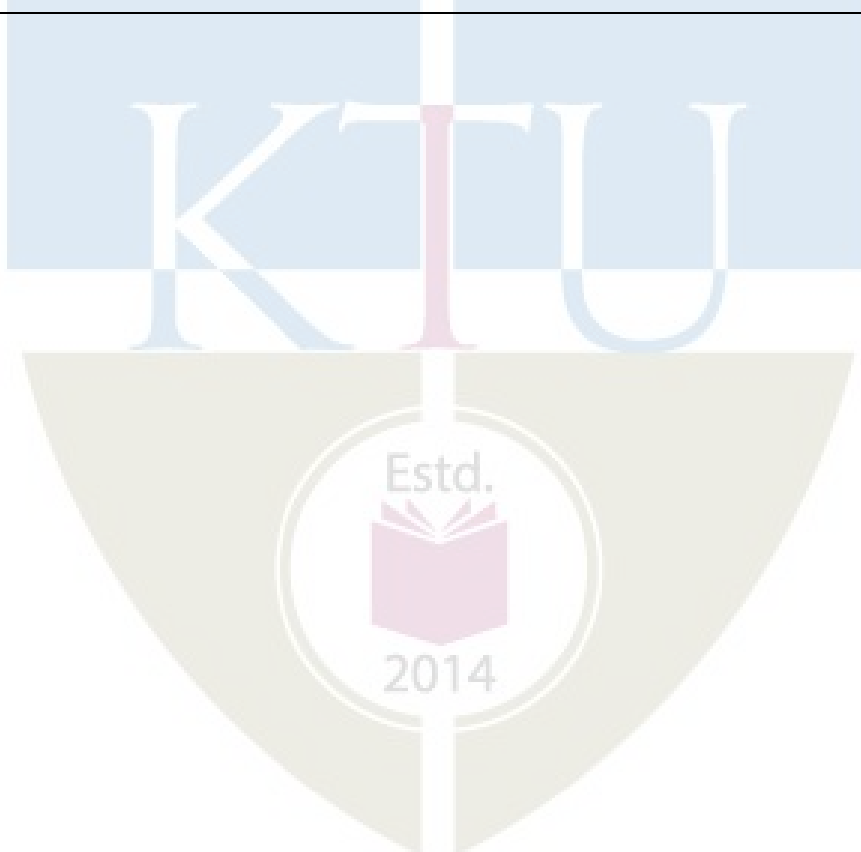

Model Question Paper

A P J ABDUL KALAM TECHNOLOGICAL UNIVERSITY
SEVENTH SEMESTER B TECH DEGREE EXAMINATION

Course: ECT425 BIOMEDICAL INSTRUMENTATION

Time:3Hrs.

Max. Marks:100

PART A

Answer All Questions

- 1 Enumerate different rhythms in EEG with frequency ranges. (3) K_1
- 2 Write short notes on the formation of bio potential signal (3) K_2
- 3 What is the difference between microelectrodes and needle electrodes? (3) K_2
- 4 With the help of a neat diagram of the Einthoven triangle, mention the necessity of the Einthoven triangle. (3) K_2
- 5 With the help of neat diagram explain ultrasonic method of blood pressure measurement. (3) K_2
- 6 Explain photoplethysmography. (3) K_2
- 7 Explain DC defibrillator with the help of neat diagram (3) K_2
- 8 What is infant incubator? How it works? (3) K_2
- 9 Mention any three applications of telemetry medicine. (3) K_1
- 10 Explain different methods of electric accident prevention. (3) K_2

PART B

Answer one question from each module. Each question carries 14 mark.

Module I

- 11(A) Describe in detail the formation of resting potential and action potential in human body (7) K_2
- 11(B) Briefly explain the physiological functions of human circulatory system (7) K_2

OR

- 12(A) Explain the problems encountered in the biomedical measurements (6) K_2
- 12(B) Briefly explain the physiological functions of human respiratory system. (8) K_2

Module II

- 13(A) Describe different bio-potential electrode used to measure bioelectric events. (6) K_2
- 13(B) Explain chopper amplifier with a neat diagram? (8) K_2

OR

- 14 Explain in details the electro conduction system of a human heart. Illustrate the same with PQRS waveform of the ECG (14) K_2

Module III

- 15(A) With help of neat diagram explain how the oscillometric method helps to measure Blood Pressure. (9) K_2
- 15(B) Write a short note on phonocardiography. (5) K_2

OR

- 16(A) What is blood pressure? How it is measured? (7) K_2
- 16(B) Explain with the help of neat diagram, impedance plethysmograph for measurement of blood flow (7) K_2

Module IV

- 17(A) Write a short note on tidal volume and vital capacity in breathing mechanism with neat diagram. (7) K_2
- 17(B) Explain heart lung machine with the help of neat diagram. (7) K_2

OR

- 18(A) Explain spirometer for measurement of respiratory parameters (7) K_2
- 18(B) Explain standard 10-20 electrode placement system for EEG measurement. (7) K_2

Module V

- 19(A) Draw the block diagram and explain the principle of ultrasound imaging. (8) K_2
- 19(B) What are the biological effects of NMR imaging over CT? (6) K_2

OR

- 20(A) What is the basic principle of CT? How image reconstruction is done in CT (8) K_2
- 20(B) How X-rays are produced? What are its properties? (6) K_2

ECT435	ELECTRONIC HARDWARE FOR ENGINEERS	CATEGORY	L	T	P	CREDIT
		OEC	2	1	0	3

Preamble: This course will introduce students the exciting field of electronic hardware designing and prototyping. This will help students to innovate faster with electronics technology.

Prerequisite: Nil

Course Outcome: After the successful completion of the course the student will be able to

CO1	Identify various electronic components along with their specifications.
CO2	Design PCB using modern software tools.
CO3	Explain various testing procedures of electronic products.
CO4	Experiment and debug various software and hardware issues of a PC.

Mapping of course outcomes with program outcomes

	PO1	PO2	PO3	PO4	PO5	PO6	PO7	PO8	PO9	PO10	PO11	PO12
CO1	3	1	1									
CO2	3	2	2		3							
CO3	3	2	2				1					
CO4	3	3	2		1							

Assessment Pattern

Bloom's Category	Continuous Assessment Tests		End Semester Examination
	1	2	
Remember	10	10	20
Understand	30	30	60
Apply	10	10	20
Analyse			
Evaluate			
Create			

Mark distribution

Total Marks	CIE	ESE	ESE Duration
150	50	100	3 hours

Continuous Internal Evaluation Pattern:

Attendance	: 10 marks
Continuous Assessment Test (2 numbers)	: 25 marks
Assignment/Quiz/Course project	: 15 marks

End Semester Examination Pattern: There will be two parts; Part A and Part B. Part A contain 10 questions with 2 questions from each module, having 3 marks for each question. Students should answer all questions. Part B contains 2 questions from each module of which student should answer any one. Each question can have maximum 2 sub-divisions and carry 14 marks.

Course Level Assessment Questions

Course Outcome 1 (CO1): Identify various electronic components along with their specifications.

1. Describe the colour coding of a 4 band resistor and find the colour code for a 470k resistor.
2. Compute the value of capacitors coded as 104 and 47K.

Course Outcome 2 (CO2): Design PCB using modern software tools.

1. Explain PCB design flow chart.
2. Design PCB layout of a regulated full wave rectifier circuit.

Course Outcome 3(CO3): Explain various testing procedures of electronic products.

1. Explain Acceptance testing and Type testing of a product.
2. Explain the testing procedure of a UPS.

Course Outcome 4 (CO4): Experiment and debug various software and hardware issues of a PC.

1. Why is it important to backup files securely? Explain the different types of backup techniques used.

SYLLABUS**MODULE I****Types of Components**

Active Components: Diode, Transistor, MOSFET, LED, SCR, Integrated Circuits(ICs)

Passive Components: Resistor, Capacitor, Inductor, Transformer, Speaker/Buzzer.

Component Package Types

Axial lead, Radial Lead, Single Inline Package(SIP), Dual Inline Package (DIP), Transistor Outline (TO), Pin Grid Array (PGA), Metal Electrode Face (MELF), Leadless Chip Carrier (LCC), Small Outline Integrated Circuit (SOIC), Quad Flat Pack(QFP) and Thin QFP(TQFP), Ball Grid Array (BGA), Plastic Leaded Chip Carrier (PLCC).

Introduction & Brief History

What is PCB, Difference between PWB and PCB, Types of PCBs: Single Sided (Single Layer), Multi-Layer (Double Layer), PCB Materials.

MODULE II**Introduction to Electronic Design Automation (EDA)**

Brief History of EDA, Latest Trends in Market, How it helps and why it requires, Different EDA tools, Introduction to SPICE and PSpice Environment, Introduction and Working of PROTEUS

Introduction to PCB Design using OrCAD tool

PCB Designing Flow Chart: Schematic Entry, Net listing, PCB Layout Designing, Prototype Designing, Design Rule Check(DRC), Design For Manufacturing(DFM)

PCB Making: Printing, Etching, Drilling, Assembly of components

Introduction to PCB Design using PROTEUS tool

Assembly of simple circuits

MODULE III**Types of Product Testing**

Acceptance Testing, Type Testing, Safety Testing, Safety, safety standards, safety certificates (CE, UL and VDE), Effect of environmental testing(refer to IEC 60068-1 for guidance)

Quality Standards

General awareness of quality standards, quality management systems & documentation, Awareness on ISO 17025, ISO 9001, Calibration and Uncertainty of measurements, Awareness on disposal of Electronic waste

Testing Procedures: Switch Mode Power Supply - (Applicable Standard: IS 14886) Safety Testing (Earth Leakage current Test, Dielectric Test, Short Circuit Protection), Performance Testing (Line Regulation, Load Regulation for a variation of Load Min to Max load and vice versa)

Inverter, UPS - Inverter (Applicable Standard: IS 13314) Visual Inspection, High Voltage Test, Insulation Resistance Test, No Load Test, Output Test. UPS (Applicable Standard: IEC 62040-3) Steady State Input Voltage Tolerance, Output-Normal Mode – No Load, Full Load, Overload, Short Circuit

Safety Testing of Household Appliances: (Applicable Standard IS 302-1) Definitions and Terminology, Protection against Shock, Power Input and Current, Leakage Current and Electric Strength at Operating Temperature

Testing of Electric Iron/Electric Kettle: (Applicable Standard: IS 302-2) Ground bond resistance, Touch Current, Temperature (Thermostatic Cut off) Power Consumption.

MODULE V

Assembly and Maintenance of PC: Introduction to Computer - Difference between Hardware & Software, Booting concept, Different input and output devices/ cables, connectors, different types of motherboard, controller cards, Ethernet cards, Different types of RAM used in PC's.

Installation: BIOS setting, Formatting of Hard Disk, Installation of Windows, Off-line drive installation / online drive installation / Windows file repairing / BIOS password break / Administrative password break / Data recovery. Application Software Installation, Dual Booting Installation.

Assembly and dismantling: Assembly and dismantling of PCs front panel connection, servicing of computer, Type of Backup, Taking Backup files and fine tuning the system, running diagnostics tool, running of virus protection program.

Text Books:

1. C. Robertson. PCB Designer's Reference. Prentice Hall, 2003.
2. D. Brooks, Signal Integrity Issues and Printed Circuit Board Design, Prentice Hall, 2003.
3. Advances in Electronic Testing, edited by D Gizopoulos, 2006

Reference Books:

1. C. Coombs, Printed Circuits Handbook, McGraw-Hill Professional, 6 edition, 2007.
2. Electronic Testing Handbook, McGraw-Hill, Dec 1993
3. PC Repair and Maintenance, A Practical Guide, Joel Rosenthal, Kevin Irwin, 2003
4. A Simple Guide to Computer Maintenance and Troubleshooting, AdaneNegaTarekegn, Alemu KumilachewTegegne, 2015

Course Plan Course Contents and Lecture Schedule

Module No	Topic	No. of Lectures
1	Active Components, Passive Components	3
	Packages: Axial lead, Radial Lead, SIP, DIP, TO,PGA, MELF, LCC, SOIC, QPF and TQFP, BGA, PLCC.	2
	PCB, Difference between PWB and PCB, Types of PCBs	1
2	Brief History of EDA, Latest Trends in Market, How? Why? Different EDA tools	1
	Introduction to SPICE and PSPICE Environment	1
	Introduction and Working of PROTEUS	2
	PCB Designing Flow Chart: Schematic Entry, Net listing, PCB Layout Designing, Prototype Designing, Design Rule Check(DRC), Design For Manufacturing(DFM)	2
	PCB Making: Printing, Etching, Drilling, Assembly of components	1
	Introduction to PCB Design using PROTEUS tool: Assembly of simple circuits	2
3	Acceptance Testing, Type Testing , Safety Testing, Safety, safety standards, safety certificates (CE, UL and VDE), Effect of environmental testing(refer to IEC 60068-1 for guidance)	3
	General awareness of quality standards, quality management systems & documentation, Awareness on ISO 17025, ISO 9001, Calibration and Uncertainty of measurements, Awareness on disposal of Electronic waste	1
4	SMPS Testing: (Applicable Standard: IS 14886) Safety Testing(Earth Leakage current Test, Dielectric Test, Short Circuit Protection), Performance Testing (Line Regulation, Load Regulation for a variation of Load Min to Max load and vice versa)	2
	Inverter (Applicable Standard: IS 13314) Visual Inspection, High Voltage Test, Insulation Resistance Test, No Load Test, Output Test. UPS (Applicable Standard: IEC 62040-3) Steady State Input Voltage Tolerance, Output-Normal Mode – No Load, Full Load, Overload, Short Circuit	2
	(Applicable Standard IS 302-1) Definitions and Terminology, Protection against Shock, Power Input and Current, Leakage Current and Electric Strength at Operating Temperature	1
	(Applicable Standard: IS 302-2) Ground bond resistance, Touch Current, Temperature (Thermostatic Cut off) Power Consumption.	1
	Difference between Hardware & Software, Booting concept	1
	Different input and output devices/ cables, connectors	1

5	Different types of motherboard, controller cards, Ethernet cards, Different types of RAM used in PC's.	1
	BIOS setting, Formatting of Hard Disk	1
	Installation of Windows, Off-line drive installation / online drive installation / Windows file repairing / BIOS password break / Administrative password break / Data recovery	2
	Application Software Installation, Dual Booting Installation.	1
	Assembly and dismantling of PCs front panel connection, servicing of computer	1
	Type of Backup, Taking Backup files and fine tuning the system, running diagnostics tool	1
	Running of virus protection program.	1

Model Question Paper

APJ ABDUL KALAM TECHNOLOGICAL UNIVERSITY
SEVENTH SEMESTER B TECH DEGREE EXAMINATION
COURSE: ECT435 ELECTRONIC HARDWARE FOR ENGINEERS
TIME: 3 HRS MAX. MARKS: 100

PART A

Answer All Questions

- | | | |
|----|--------------------------------------------------------------------------|---|
| 1 | Differentiate between active and passive components. | 3 |
| 2 | List any six type of electronic component packages. | 3 |
| 3 | State Moore's law and how it is related to electronic design automation. | 3 |
| 4 | What is a Gerber file? How it is used while making a PCB? | 3 |
| 5 | What does CE certification in electronic product mean? | 3 |
| 6 | What does ISO IEC stand for? | 3 |
| 7 | What do you mean by line regulation in a power supply? | 3 |
| 8 | How is leakage current of a device related to temperature? | 3 |
| 9 | Write the operations taking place during the booting of a system | 3 |
| 10 | Does Windows have a data recovery tool? If so, Explain. | 3 |

PART B

Answer one question from each module. Each question carries 14 marks.

Module I

- | | | |
|-------|-------------------------------------------------------------|---|
| 11(A) | Compare Dual Inline Package and Ball Grid Array IC Package. | 8 |
| 11(B) | Compute the value of capacitors coded as 103 and 4K7. | 6 |

OR

- | | | |
|-------|-----------------------------------------------------------------------------------------------|---|
| 12(A) | Describe the colour coding of a 4 band resistor and find the colour code for a 2.2k resistor. | 7 |
| 12(B) | Make a note on different types of PCBs. | 7 |

Module II

- 13(A) Explain the process of manufacturing PCB from a PCB layout. 6
- 13(B) Explain the relevance of Design Rule Check and Design For Manufacturing in PCB development. 8

OR

- 14(A) Explain PCB design flow chart. 8
- 14(B) Make a note on the tool PROTEUS and explain how it is different from OrCAD. 6

Module III

- 15(A) Explain Acceptance testing and Type testing of a product. 8
- 15(B) Explain different ways for disposal of Electronic waste. 6

OR

- 16(A) What are uncertainties in measurements? How can you quantify it? 8
- 16(B) What is IEC 60068-1 ? What properties of the specimen is it concerned about? 6

Module IV

- 17(A) Explain the testing procedure of an SMPS. 10
- 17(B) Explain the relevance of Insulation resistance test. 4

OR

- 18(A) Explain the testing procedure of an Inverter. 10
- 18(B) What does IS 302 standard part 1 refer to? 4

Module V

- 19(A) Explain the different types of computer RAM with their pros and cons. 7
- 19(B) What is the difference between an online drive installation and an offline drive installation in case of windows? Explain the installation process. 7

OR

- 20(A) What are the various steps involved in Assembly and dismantling of PCs front panel connection? 8
- 20(B) How can a user install two operating systems in a single computer? Explain. 6

ECT445	IOT AND APPLICATIONS	CATEGORY	L	T	P	CREDIT
		OEC	2	1	0	3

Preamble: This course aims to develop skills in IoT system development and to apply the same in real life applications.

Prerequisite: ECT342 Embedded systems and ECT401 Wireless communication (optional)

Course Outcomes: After the completion of the course, a student will be able to

CO 1 K1	Understand the IoT fundamentals and architecture modeling (K1)
CO 2 K2	Understand the smart things in IoT and functional blocks (K2)
CO3 K2	To understand the communication networks and protocols used in IoT. (K2)
CO 4 K3	To understand the cloud resources, data analysis and applications. (K3)
CO5 K3	To apply the IoT processes in embedded applications. (K3)

Mapping of course outcomes with program outcomes

	PO 1	PO 2	PO 3	PO 4	PO 5	PO 6	PO 7	PO 8	PO 9	PO 10	PO 11	PO 12
CO 1	3	3	2		1			2				2
CO 2	3	3	3		3			2				2
CO 3	3	3	3		3			2	3			2

Assessment Pattern

Bloom's Category		Continuous Assessment Tests		End Semester Examination
		1	2	
Remember	K1	20	10	20
Understand	K2	30	20	40
Apply	K3	0	20	40
Analyse				
Evaluate				
Create				

Mark distribution

Total Marks	CIE	ESE	ESE Duration
150	50	100	3 hours

Internal Evaluation Pattern:

Attendance : 10 marks
 Continuous Assessment Test (2 numbers) : 25 marks
 Assignment/Quiz/Course project : 15 marks

End Semester Examination Pattern: There will be two parts; Part A and Part B. Part A contain 10 questions with 2 questions from each module, having 3 marks for each question. Students should answer all questions. Part B contains 2 questions from each module of which student should answer any one. Each question can have maximum 2 sub-divisions and carry 14 marks.

Course Level Assessment Questions

Course Outcome 1 (CO1): Understand the IoT fundamentals and architecture modeling (K1)

1. What is the definition of IoT and different characteristics of IoT
2. Define the architectural view of IoT and functional blocks
3. What are the different levels of IoT

Course Outcome 2 (CO2): Understand the smart things in IoT and functional blocks (K2)

1. What are the different smart things in IoT
2. How the communication is established among nodes and nodes and cloud.
3. What are the protocols that are used in IoT

Course Outcome 3 (CO3): To understand the communication networks and protocols used in IoT. (K2)

1. Differentiate between IEEE standard protocols
2. Explain the advantages of next generation IP based protocols used in IoT
3. Define different layers used in embedded protocols

Course Outcome 4 (CO4): To understand the cloud resources, data analysis and applications. (K3)

1. Explain how data is stored in IoT environment and processed
2. How to use cloud resources and different options available
3. How end devices can be used to control input and output devices

Course Outcome 5 (CO5): To apply the IoT processes in embedded applications. (K3)

1. What are the security and privacy concerns of IoT
2. Explain the typical applications of IoT.
3. Describe the processes involved in implementing a smart city.

SYLLABUS

Module 1 (7 Hours)

Introduction to IoT technology: Definitions and Characteristics of IoT, IoT Architectural View, Physical Design of IOT, Logical Design of IoT- IoT Functional blocks, IoT communication models, IoT Enabling Technologies, IoT Levels & Deployment Templates.

Module 2 (7 Hours)

IoT and M2M- M2M, Difference between IoT and M2M, SDN and NFV for IoT, Smart Objects: The “Things” in IoT: Sensors, Actuators, and Smart Objects, Sensor Networks- Wireless Sensor Networks (WSNs), Communication Protocols for Wireless Sensor Networks- Connecting Smart Objects- Communication Criteria.

Module 3 (7 Hours)

Unified Data Standards –Protocols –IEEE 802.15.4 -The Physical Layer, The Media-Access Control Layer, Uses of 802.15.4 ,The Future of 802.15.4: 802.15.4e and 802.15.4g–Modbus–ZigBee-Zigbee Architecture- LoRaWAN -Standardization and Alliances, Physical Layer, MAC Layer, Topology, LTE-M, NB-IoT-Network layer –The next generation: IP-based protocols - 6LoWPAN and RPL, Overview of the 6LoWPAN Adaptation Layer .

Module 4 (9 hours)

Data Collection, storage and computing Using a Cloud Platform-Introduction, Cloud Computing Paradigm for Data Collection, Storage and Computing-Cloud Computing Paradigm, Cloud Deployment Models-Everything as a Service and Cloud Service Models-SaaS, PaaS, IaaS, DaaS. Cloud based platforms-XIVELY, NIMBITS.

IoT Physical Devices & Endpoints-IoT Device-Building blocks –Raspberry-Pi -Board-Linux on Raspberry-Pi-Raspberry-Pi Interfaces (serial, SPI, I2C). Raspberry Pi interfacing and programming examples using python (LED, switch, sensor, serial, SPI, I2C devices). Controlling GPIO outputs and displaying sensor readings using web interface/cloud (Python programming is required only for assignments and projects and not for examinations. Other end nodes and platforms can also be used).

Module 5 (6 Hours)

IoT privacy, security and vulnerabilities solutions, vulnerabilities, security requirements, threat analysis, security tomography, layered attacker model, Identity management, access control, secure message communication.

Smart and Connected Cities-An IoT Strategy for Smarter Cities-Vertical IoT Needs for Smarter Cities, Global vs. Siloed Strategies-Smart City IoT Architecture-Street Layer, City Layer, Data Center Layer, Services Layer- Smart City Security Architecture - Smart City Use-Case Examples – Street lighting, smart parking, smart traffic and air pollution monitoring

Maximum 35 /36 Hours

Text Books

1. Vijay Madiseti and ArshdeepBahga, “Internet of Things (A Hands-on- Approach)”, 1st Edition, VPT, 2014 (Module1,2,4)
2. David Hanes, Gonzalo Salgueiro, Patrick Grossetete, Rob Barton and Jerome Henry, —IoT Fundamentals: Networking Technologies, Protocols and Use Cases for Internet of Things, Cisco Press, 2017. (Module2,3,5)
3. Rajkamal, “Internet of Things : Architecture and Design Principles”, McGraw Hill (India) Private Limited.
4. Raspberry Pi Cookbook, Software and Hardware Problems and solutions, SimonMonk, O'Reilly (SPD), 2016, ISBN.

Reference Books/Papers

1. Olivier Hersent, David Boswarthick, Omar Elloumi , “The Internet of Things –Key applications and Protocols”, Wiley, 2012 (Module 3)
2. Al-Fuqaha et al. Internet of things: A survey on enabling technologies, protocols, and applications. IEEE Communications Surveys & Tutorials (2015), pp. 2347- 2376.
3. The Internet of Things (The MIT Press Essential Knowledge series) Paperback – March 20, 2015 by SamuelGreengard
4. The Internet of Things: Converging Technologies for Smart Environments and Integrated Ecosystems, OviduVermesan and Peter Friess, RiverPublishers.
5. Internet of Things - From Research and Innovation to Market Deployment-RIVER PUBLISHERS, PETER FRIESS, OVIDIU VERMESAN (Editors)
6. Internet of Things Security and Data Protection, Sébastien Ziegler, Springer

International Publishing 2019.

Course Contents and Lecture Schedule

No	Topic	No. of Lectures
1	Introduction to Internet of Things- 7Hrs	
1.1	Introduction, definition and characteristics	1
1.2	IoT architectural view, functional blocks	2
1.3	IoT Communication models, enabling technologies	2
1.4	IoT deployment levels	2
2	Essential components of IoT- 7Hrs	
2.1	IoT and M2M	2
2.2	Smart objects	2
2.3	Wireless sensor networks	3
3	IoT protocols- 7Hrs	
3.1	IEEE 802.15.4 protocols	2
3.2	Zigbee	1
3.3	6LoWPAN and RPL	2
3.4	LoraWAN, LTE-M and NB-IoT	2
4	Cloud storage and Programming the end device- 9Hrs	
4.1	Data storage and computation	3
4.2	Physical devices and end points	2
4.3	Raspberry pi programming	4
5	Security and Applications-6 Hrs	
5.1	Security and Privacy	2
5.2	Smart city application	2
5.3	Use case examples	2

Simulation Assignments:

1. At least one assignment should be programming examples (python or any other language) using Raspberry pi (Other options like arduino, node mcu etc. can also be used) Include I/O interfacing, SPI, I2C, serial, sensor interfacing and web interface.
2. Another assignment shall be an IoT system implementation of mini project consisting of a sensor, processing device, communication device and cloud storage (This can be individual or group projects). Mini project is essential for understanding the concepts of IoT.
3. Mini project can be done in the following areas.
 - a) Smart city (b) Weather monitoring system (c) air pollution monitoring (d) Smart parking (e) smart traffic (f) any other application/s where sensors/actuators devices are used.
4. Programming and mini project are essential for understanding the concepts of IoT.

Model Question Paper

APJ ABDUL KALAM TECHNOLOGICAL UNIVERSITY

SEVENTH SEMESTER B.TECH DEGREE EXAMINATION, (Model Question Paper)

Course Code: ECT445

Course Name: IOT AND APPLICATIONS

Max. Marks: 100

Duration: 3 Hours

PART A

(Answer for all questions. Each Question Carries 3 marks)

1. List any five characteristics of IoT
2. What are the IoT enabling technologies?
3. What is a wireless sensor network?
4. What are the limitations of smart objects in WSNs??
5. Explain the need for IP optimization in IoTs?
6. What are the transmission modes used in modbus?
7. What are the 4 different cloud deployment models? Explain
8. What is cloud computing? Explain.
9. List the five functional units of security
10. What is message integrity? How it is checked? [10 X 3 = 30 Marks]

PART – B

(Answer one question from each module; each question carries 14 Marks)

Module – I

11. (a) Write a note on physical design of IoT. [06 Marks]
(b) Give a detailed description of the link layer, network layer, transport layer and application layer protocols. [08 Marks]

OR

12. (a) What are the functional blocks of IoT? Explain? [07 Marks]
(b) Discuss different communication models used in IoT. [07 Marks]

Module – II

13. (a) What are the differences between IoT and M2M? [07 Marks]
(b) What are the issues of conventional networking architectures? How is it solved in SDN? [07 Marks]

OR

14. (a) What are smart objects? What are their characteristics and the trends in smart objects? [07 Marks]
(b) What are the characteristics and attributes to be considered for connecting smart objects? [07 Marks]

Module – III

15. (a) Explain IEEE 802.15.4 physical layer, MAC layer and security implementation with the help of frame formats. [09 Marks]
(b) What are the modifications included in IEEE 802.15.4 e and g versions as compared to IEEE 802.15.4? [05 Marks]

OR

16. (a) With the help of a diagram explain the Zigbee protocol architecture. [07 Marks]
(b) Explain LoraWAN architecture. Give a detailed description of the physical layer and MAC layer of LoraWAN [07 Marks]

Module – IV

17. (a) Write a note on different cloud service models [06 Marks]
(b) What is virtualization in cloud computing? Explain the features, advantages and concerns of cloud computing. [08 Marks]

OR

18. (a) With the help of a diagram explain the basic building blocks of an IoT device [07 Marks]
- (b) Explain cloud based data collection, storage and computing services provided by XIVELY cloud platform. [07 Marks]

Module – V

19. (a) What is security and Privacy? List the 10 vulnerabilities of IoT. [07 Marks]
- (b) Explain the layered attacker model. [07 Marks]

OR

20. (a) With the help of a diagram explain the 4 layer smart city architecture. [07 Marks]
- (b) Write a note on street lighting architecture with the help of a diagram [07 Marks]

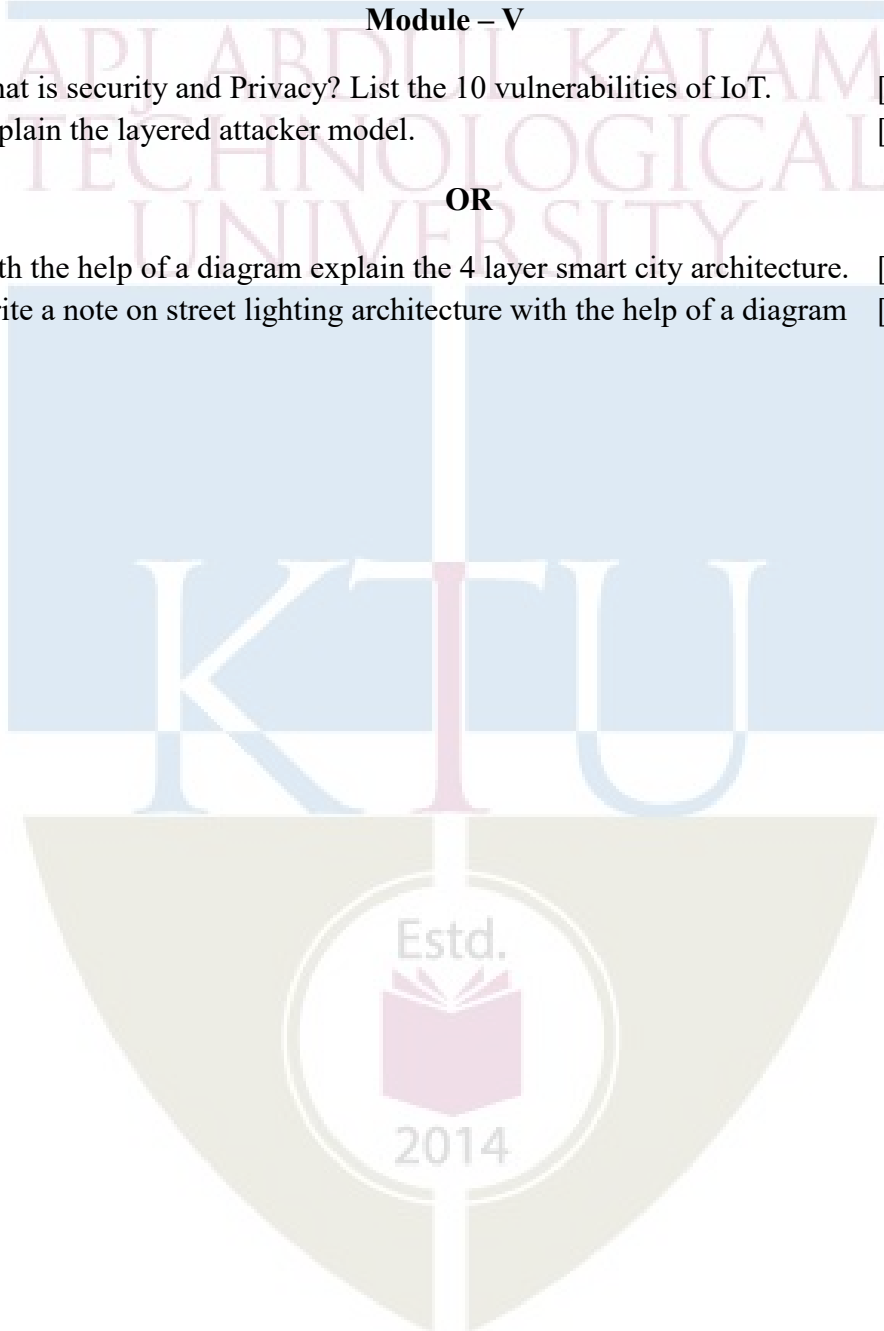

ECT455	ENTERTAINMENT ELECTRONICS	CATEGORY	L	T	P	CREDIT
		OEC	2	1	0	3

Prerequisite: Nil

Course objectives: The course aims to provide broad knowledge on various industry standards, algorithms and technologies used to carry out digital audio and video broadcasting in infotainment industry.

Course Outcomes: After the completion of the course the student will be able to

CO1 K2	Understand packetized streaming of digital media happens in the field of infotainment industry.
CO2 K2	Realise the critical aspects of DVB and DAB standards used for media broadcasting in infotainment industry.
CO3 K3	Apply video coding/compression algorithms are used to produce high-definition video in MPEG-4 standard.
CO4 K2	Understand modern display technologies for video reproduction.

Mapping of course outcomes with program outcomes

	PO 1	PO 2	PO 3	PO 4	PO 5	PO 6	PO 7	PO 8	PO 9	PO 10	PO 11	PO 12
CO 1	3	3										2
CO 2	3	3			2						2	2
CO 3	3	3			3						2	2
CO 4	3	3										2

Assessment Pattern

Bloom's Category		Continuous Assessment Tests		End Semester Examination
		1	2	
Remember	K1	10	10	20
Understand	K2	40	30	60
Apply	K3		10	20
Analyse				
Evaluate				
Create				

Mark distribution

Total Marks	CIE	ESE	ESE Duration
150	50	100	3 hours

Continuous Internal Evaluation Pattern:

Attendance	: 10 marks
Continuous Assessment Test (2 numbers)	: 25 marks
Assignment/Quiz/Course project	: 15 marks

End Semester Examination Pattern: There will be two parts; Part A and Part B. Part A contain 10 questions with 2 questions from each module, having 3 marks for each question. Students should answer all questions. Part B contains 2 questions from each module of which student should answer any one. Each question can have maximum 2 sub-divisions and carry 14 marks. Mark patterns are as per the syllabus with 100 % for theory.

Course Level Assessment Questions

Course Outcome 1 (CO1): Explain packetized streaming of digital media happens in the field of infotainment industry.

1. Discuss MPEG-2 standards for streaming multimedia data and aspects of synchronization, accessing scrambled programs and program synchronization.

Course Outcome 2 (CO2): Discuss the critical aspects of DVB and DAB standards used for media broadcasting in infotainment industry.

1. Describe the existing standards and features for modulation and demodulation schemes related with DAB, various types of DVB and DRM.

Course Outcome 3 (CO3): Explain how the video coding/compression algorithms are used to produce high-definition video in MPEG-4 standard.

1. Understanding quantization, DCT, differential PCM for MPEG-4 video compression.
2. Developing audio sub-band coding methods based on psychoacoustic model of human ear.

Course Outcome 4 (CO4): Discuss modern display technologies for video reproduction.

1. Explain the basic principles of video reproduction and display technology such as CRT, LCD, plasma and OLED

ELECTRONICS & COMMUNICATION ENGINEERING
SYLLABUS

Module	Course contents	Hours
I	<p>Brief Review of Analog Television: Scanning, Horizontal and Vertical Synchronization, Color information, Transmission methods. NTSC and PAL standards.</p> <p>Digital media streaming: Packetized elementary stream of audio-video data, MPEG data stream, MPEG-2 transport stream packet, Accessing a program, scrambled programs, program synchronization. PSI, Additional (Network information and service description) information in data streams for set-top boxes.</p>	7
II	<p>Digital Video Broadcasting (DVB): Satellite TV broadcasting – DVB-S Parameters, DVB-S Modulator, DVB-S set-top box, DVB-S2.</p> <p>Cable TV broadcasting – DVB-C Standard, DVB-C Modulator, DVB-C set-top box.</p> <p>Terrestrial TV broadcasting – DVB-T Standard, DVB-T Modulator, DVB-T Carriers and System Parameters, DVB-T receiver.</p> <p>Broadcasting for Handheld devices – DVB-H Standard</p> <p>DVB tele-text, DVB subtitling system.</p>	7
III	<p>Digital Audio Broadcasting (DAB): Comparison of DAB with DVB. Physical layer of DAB. DAB Modulator, DAB Data Structure, DAB single frequency networks, Data broadcasting using DAB.</p> <p>Digital Radio Mondiale (DRM): Transmitter and receiver, Data rates.</p>	6
IV	<p>High Definition Video and Audio: Pixel resolution, Comparison with Standard Definition TV, Review of Discrete Cosine Transforms (DCT), Video Compression - Quantization levels, Horizontal/Vertical blanking interval, Vertical Color resolution, DPCM of moving pictures, DCT, Run-length coding. MPEG-4 Video coding.</p> <p>Psycho-acoustic model, Principle of audio coding, Sub-band coding in MPEG layer 1 and 2, MPEG Layer 3 and Dolby Digital, Multichannel sound.</p>	8
V	<p>Display Technology: Block diagram of video reproduction system in a TV, Cathode Ray tubes, Basic principle of Plasma displays, LC displays, Light-emitting diode displays, Field emission displays, Organic light emitting device displays.</p>	7

	Television of future: Holographic TV, Virtual Reality, Augmented Reality.	
--	----------------------------------------------------------------------------------	--

Textbooks

1. W. Fischer, Digital Video and Audio Broadcasting Technology: A Practical Engineering Guide (Signals and Communication Technology), Springer, 2020
2. Lars-Ingemar Lundström, Understanding Digital Television An Introduction to DVB Systems with Satellite, Cable, Broadband and Terrestrial TV, Focal Press, Elsevier, 2006.
3. K F Ibrahim, Newnes Guide to Televeision and Video Technology, Newnes, 2007.
4. Jiun-Haw Lee, David N. Liu, Shin-Tson Wu, Introduction to Flat Panel Displays, Wiley, 2008.

References

1. C. Poynton, "Digital Video and HD Algorithms and Interfaces,"Morgan Kaufmann, 2012.
2. Wolfgang Hoeg, Thomas Lauterbach, Digital audio broadcasting: principles and applications of DAB, DAB+ and DMB, Wiley, 2009.
3. John Watkinson, Introduction to Digital Audio, Focal Press, 1994.
4. John Watkinson, Art of Digital Video, Focal Press, 2008.
5. John Watkinson, Introduction to Digital Video, Focal Press, 2001.

Course content and Lecture plan

No	TOPIC	No of Lectures
MODULE 1		
1.1	Analog Television, Scanning, Horizontal and Vertical Synchronization, Colour information, NTSC and PAL standards.	2
1.2	Analog TV Transmission	1
1.3	Packetized elementary stream. MPEG data stream, MPEG-2 transport stream packet	2
1.4	Accessing a program, scrambled programs, program synchronization. Program Specific Information	1
1.5	Additional (Network information and service description) information in data streams	1
MODULE II		
2.1	Introduction to DVB, DVB-S Parameters, DVB-S Modulator, DVB-S set-top box, DVB-S2.	2
2.2	DVB-C Standard, DVB-C Modulator, DVB-C set-top box.	1
2.3	DVB-T Standard, DVB-T Modulator, DVB-T Carriers and System Parameters, DVB-T receiver.	2

2.4	Broadcasting for Handheld devices – DVB-H Standard	1
2.5	DVB teletext, DVB subtitling system.	1
MODULE III		
3.1	Introduction to DAB, Comparison of DAB with DVB.	1
3.2	Physical layer of DAB. DAB Modulator, DAB Data Structure, DAB single frequency networks, Data broadcasting using DAB.	3
3.3	Digital Radio Mondiale (DRM): Transmitter and receiver, Data rates.	2
MODULE IV		
4.1	HDTV versus SDTV, Pixel resolution,	1
4.2	Review of Discrete Cosine Transforms (DCT)	1
4.3	Video Compression - Quantization levels, Horizontal/Vertical blanking interval, Vertical Colour resolution, DPCM of moving pictures, DCT, Run-length and Huffman coding. MPEG-4.	3
4.4	Psychoacoustic model, Principle of audio coding	1
4.5	Subband coding in MPEG layer 1 and 2	1
4.6	MPEG Layer 3 and Dolby Digital, Multichannel sound	1
MODULE V		
5.1	Block diagram of video reproduction system in a TV	1
5.2	Cathode Ray tubes	1
5.3	Basic principle of Plasma displays, LC displays, Light-emitting diode displays, Field emission displays, Organic light emitting device displays.	3
5.4	Holographic TV, Virtual Reality, Augmented Reality.	2

Simulation Assignments (optional)

- 1 Realise live streaming of audio and video data using Python/MATLAB-Simulink or other platforms.
- 2 Realise a basic video compression scheme from basic principles studied from this course using Python/MATLAB. Obtain the performance parameters before and after comparison.
- 3 Simulate a DAB transmitter and receiver system using MATLAB/Simulink and study its Performance under Gaussian noise.

Model Question paper**APJ ABDUL KALAM TECHNOLOGICAL UNIVERSITY**VII SEMESTER B. TECH DEGREE EXAMINATION, (**Model Question Paper**)**Course Code: ECT455****Course Name: ENTERTAINMENT ELECTRONICS**

Max. Marks: 100

Duration: 3 Hours

PART A		
Answer all questions, each carries 3 marks		
1.	Compare interlaced scanning and progressive scanning.	3
2	What is the maximum video signal frequency in PAL TV system? How is it obtained?	3
3	Mention the differences between DVB-C and DVB-S modulators.	3
4	A DVB-C coaxial system uses 64QAM modulation with symbol rate 69 Mega symbols/s. Roll-off factor used is 0.15. Compute the gross data rate.	3
5	Write short notes on coded OFDM.	3
6	What is the function of the Ensemble Transport Interface (ETI) in DAB system? Explain.	3
7	With a suitable example, illustrate run length encoding.	3
8	Define discrete cosine transform. How is it important in signal compression?	3
9	List the essential features of LCD screen compared to CRT/plasma displays.	3
10	Differentiate between virtual reality and augmented reality.	3
		10x3=30
PART B		
Answer any one full question from each module carries 14 marks.		
MODULE 1		
11a	Sketch the frequency spectrum of typical PAL TV system. Show the bandwidth, vision carrier, sound carrier and guard band frequencies.	7
11b	Explain the packetized elementary streams in MPEG	7
OR		
12a	What is the need of vertical sync pulses and equalising pulses in PAL	7

	TV system? Explain with necessary diagrams.	
12b	Explain how program synchronisation is achieved in MPEG-2.	7
	MODULE II	
13a	With a block diagram explain DVB-C modulator.	7
13b	With a block diagram explain the basic units in digital receiver/decoder set-top-box in digital TV.	7
	OR	
14a	How DVB-T modulator can be implemented using IFFT blocks? Explain.	7
14b	Explain the requirements of a standard on digital video broadcasting for hand held mobile terminals.	7
	MODULE III	
15a	Explain the details of physical layer in DAB.	7
15b	Compare DAB and DVB.	
	OR	
16a	With a block diagram explain DAB modulator and transmitter.	7
16b	Describe the essential features of Digital Radio Mondiale.	7
	MODULE IV	
17a	Explain subband coding technique in layers I,II of MPEG1, MPEG 2.	7
17b	With relevant details illustrate how the principle differential pulse code modulation can be applied in MPEG 1 and MPEG 2 video compression methods.	7
	OR	
18a	Explain a technical model for human ear, which will help in audio coding. How this principle can be applied for developing an audio coding scheme for compression.	7
18b	Explain any one type of transform coding principle for video compression.	7
	MODULE V	
19a	With a diagram explain the principle of working of a two layer organic LED device.	7
19b	Explain the advantages and disadvantages of plasma displays.	7
	OR	
20a	With a neat diagram explain the working of any one type of cathode ray tube.	7
20b	Explain the applications of virtual reality technology.	7

MCN401	INDUSTRIAL SAFETY ENGINEERING	Category	L	T	P	CREDIT
		OEC	2	1	0	3

Preamble: The course is intended to give knowledge of various safety management principles, various safety systems, various machine guarding devices, hazard identification techniques, energy sources, systems & applications and the need in the present context. Learners will be able to compare different hazard identification tools and choose the most appropriate based on the nature of industry. It aims to equip students in working with projects and to take up research work in connected areas

Prerequisite: Nil

Course Outcomes: After the completion of the course the student will be able to

CO1	Describe the theories of accident causation and preventive measures of industrial accidents. (Cognitive Knowledge level: Understand)
CO2	Explain about personal protective equipment, its selection, safety performance & indicators and importance of housekeeping. (Cognitive Knowledge level: Understand)
CO3	Explain different issues in construction industries. (Cognitive Knowledge level: Understand)
CO4	Describe various hazards associated with different machines and mechanical material handling. (Cognitive Knowledge level: Understand)
CO5	Utilise different hazard identification tools in different industries with the knowledge of different types of chemical hazards. (Cognitive Knowledge level: Apply)

Mapping of course outcomes with program outcomes

	PO1	PO2	PO3	PO4	PO5	PO6	PO7	PO8	PO9	PO10	PO11	PO12
CO1	2	2				2	2	2				1
CO2	2	1	2		1	1	1	1				1
CO3	2	2	2		1	1	1	1	1	1		1
CO4	2	2	2		1	1	1	1	1	1		1
CO5	2	2	2	1	1	1	1	1	1	1		1

Abstract POs defined by National Board of Accreditation				
PO1	Engineering Knowledge		PO7	Environment and Sustainability
PO2	Problem Analysis		PO8	Ethics
PO3	Design/Development of solutions		PO9	Individual and team work
PO4	Conduct investigations of complex problems		PO10	Communication
PO5	Modern tool usage		PO11	Project Management and Finance
PO6	The Engineer and Society		PO12	Life long learning

Assessment Pattern

	Continuous Assessment Tests		End Semester Examination
	1	2	
Remember	10	10	10
Understand	20	20	20
Apply	20	20	70
Analyse			
Evaluate			
Create			

Mark distribution:

Total Marks	CIE Marks	ESE Marks	ESE Duration
150	50	100	3 hours

Continuous Internal Evaluation Pattern:

Attendance : 10 marks

Continuous Assessment - Test : 25 marks

Continuous Assessment - Assignment : 15 marks

Internal Examination Pattern:

Each of the two internal examinations has to be conducted out of 50 marks. First series test shall be preferably conducted after completing the first half of the syllabus and the second series test shall be preferably conducted after completing remaining part of the syllabus. There will be two parts: Part A and Part B. Part A contains 5 questions (preferably, 2 questions each from the completed modules and 1 question from the partly completed module), having 3 marks for each question adding up to 15 marks for part A. Students should answer all questions from Part A. Part B contains 7 questions (preferably, 3 questions each from the completed modules and 1 question from the partly completed module), each with 7 marks. Out of the 7 questions, a student should answer any 5.

End Semester Examination Pattern:

There will be two parts; Part A and Part B. Part A contains 10 questions with 2 questions from each module, having 3 marks for each question. Students should answer all questions. Part B contains 2 questions from each module of which a student should answer any one. Each question can have maximum 2 sub-divisions and carries 14 marks.

Syllabus

MCN401- Industrial Safety Engineering (35 hrs)

Module I (safety introduction- 5 hrs)

Need for safety. Safety and productivity. Definitions: Accident, Injury, Unsafe act, Unsafe Condition, Dangerous Occurrence, Reportable accidents. Theories of accident causation. Safety organization- objectives, types, functions, Role of management, supervisors, workmen, unions, government and voluntary agencies in safety. Safety policy. Safety Officer-responsibilities, authority. Safety committee-need, types, advantages.

Module II (Personal protection in work environment- 7 hrs)

Personal protection in the work environment, Types of PPEs, Personal protective equipment- respiratory and non-respiratory equipment. Standards related to PPEs. Monitoring Safety Performance: Frequency rate, severity rate, incidence rate, activity rate. Housekeeping: Responsibility of management and employees. Advantages of good housekeeping. 5 s of housekeeping. Work permit system- objectives, hot work and cold work permits. Typical industrial models and methodology. Entry into confined spaces.

Module III (safety issues in construction- 7 hrs)

Introduction to construction industry and safety issues in construction Safety in various construction operations – Excavation and filling – Under-water works – Under-pinning & Shoring – Ladders & Scaffolds – Tunneling – Blasting – Demolition – Confined space – Temporary Structures. Familiarization with relevant Indian Standards and the National Building Code provisions on construction safety. Relevance of ergonomics in construction safety. Ergonomics Hazards - Musculoskeletal Disorders and Cumulative Trauma Disorders.

Module IV (safety hazards in machines- 8 hrs)

Machinery safeguard-Point-of-Operation, Principle of machine guarding -types of guards and devices. Safety in turning, and grinding. Welding and Cutting-Safety Precautions of Gas

welding and Arc Welding. Material Handling-Classification-safety consideration- manual and mechanical handling. Handling assessments and techniques- lifting, carrying, pulling, pushing, palletizing and stocking. Material Handling equipment-operation & maintenance. Maintenance of common elements-wire rope, chains slings, hooks, clamps. Hearing Conservation Program in Production industries.

Module V (hazard identification and analysis- 8 hrs)

Hazard and risk, Types of hazards –Classification of Fire, Types of Fire extinguishers, fire explosion and toxic gas release, Structure of hazard identification and risk assessment. Identification of hazards: Inventory analysis, Fire and explosion hazard rating of process plants - The Dow Fire and Explosion Hazard Index, Preliminary hazard analysis, Hazard and Operability study (HAZOP) – methodology, criticality analysis, corrective action and follow-up. Control of Chemical Hazards, Hazardous properties of chemicals, Material Safety Data Sheets (MSDS).

Text Books:

1. R.K Jain (2000) Industrial Safety, Health and Environment management systems, Khanna Publications.
2. Paul S V (2000), Safety management System and Documentation training Programme handbook, CBS Publication.
3. Krishnan, N.V. (1997). *Safety management in Industry*. Jaico Publishing House, New Delhi.
4. John V. Grimaldi and Rollin H.Simonds. (1989) *Safety management*. All India Traveller Book Seller, Delhi.
5. Ronald P. Blake. (1973). *Industrial safety*. Prentice Hall, New Delhi.
6. Alan Waring. (1996). *Safety management system*. Chapman & Hall, England.
7. Vaid, K.N., (1988). Construction safety management. National Institute of Construction Management and Research, Mumbai.

8. AIChE/CCPS. (1992). *Guidelines for Hazard Evaluation Procedures*. (second edition). Centre for Chemical Process Safety, American Institute of Chemical Engineers, New York.

Course Level Assessment Questions:

Course Outcome 1 (CO1):

1. Which are the various accident causation theories? Explain.
2. Define terms: Accident, Reportable accident, Dangerous occurrence.

Course Outcome 2 (CO2):

1. Discuss different types of personal protective equipment
2. Discuss about how to compare the safety performance of two industries.
3. Discuss the significance of work permit system in accident prevention.

Course Outcome 3 (CO3):

1. Distinguish ladders and scaffolds along with their safety features.
2. Discuss the safety requirement for a confined space entry.
3. Explain the important provision in the National Building Code.

Course Outcome 4 (CO4):

1. Explain the various principles used in machine guarding.
2. Explain the issues in mechanical material handling.

Course Outcome 5 (CO5):

1. Selection of different types of fire extinguishers accordance to type of fire.
2. Conduct a HAZOP study for a batch reactor of your choice.
3. Determine different types of Chemical hazards associated with industries

MODEL QUESTION PAPER
APJ ABDUL KALAM TECHNOLOGICAL UNIVERSITY
VII SEMESTER B. TECH DEGREE EXAMINATION
MCN401- INDUSTRIAL SAFETY ENGINEERING

Maximum: 100 Marks

Duration: 3 hours

PART A

Answer all questions, each question carries 3 marks

1. Differentiate Unsafe act and Unsafe conditions with suitable examples
2. Discuss the significance of a safety committee in improving the safety performance of an industry
3. Which are the different types of permit? Highlight its suitability.
4. Which are five 'S' used in housekeeping?
5. List the various safety features of ladders.
6. How safety of the workers can be ensured during a demolition operations.
7. Which are the hazards associated with manual material handling?
8. Discuss the safety issues of Gas welding operations.
9. Differentiate Hazard and Risk.
10. Why MSDS is mandatory for chemical products.

(10 X 3 = 30 Marks)

PART B

Answer one full question from each module

Module 1

11. List the various accident causation theories and explain any one in details. (14 Marks)
12. a) Discuss the significance of safety policy in reducing the accidents. (4 Marks)
b) Safety and productivity are the two sides of a coin'. Are you agreeing with this statement? Explain with your arguments. (10 Marks)

Module 2

13. a) Classify the personal protective equipment. List the suitability of at least fifteen types of PPEs. (10 Marks)

b) How will you calculate the frequency rate? Explain with an example. (4 Marks)

14. a) How will you compare the safety performance of two industries? Explain with suitable example. (10 Marks)

b) Which are the steps to be followed in confined space entry to protect the life of a worker. (4 Marks)

Module 3

15. Discuss the safety and fire protection facilities required for a high rise building as per National building code. (14 Marks)

16. a) Identify the various hazards during the different stages of building construction. (7 Marks)

b) Discuss the important types of ergonomic hazards associated with industries. (7 Marks)

Module 4

17. Which are the various types of machine guarding devices used in industries. Discuss the suitability of each machine guarding device. (14 Marks)

18. With suitable sketches briefly explain seven defects of wire ropes. (14 Marks)

Module 5

19. What is Hazard and Operability Analysis? How do you conduct a HAZOP analysis? (14 Marks)

20. Discuss about different types of chemical hazards. (14 Marks)

Course Contents and Lecture Schedule

No.	Topic	No. of Lectures/ Tutorials L-T
1	Introduction to Industrial safety Engineering	
1.1	Need for safety. Safety and productivity. Definitions: Accident, Injury, Unsafe act, Unsafe Condition, Dangerous Occurrence. Reportable accidents	1
1.2	Theories of accident causation. Safety organization.	2
1.3	Role of management, supervisors, workmen, unions, government and voluntary agencies in safety.	3
1.4	Safety Officer-responsibilities, authority.	4
1.5	Safety committee-need, types, advantages.	5
2	Personal protection in the work environment	
2.1	Types of PPEs, respiratory and non-respiratory equipment.	6
2.2	Standards related to PPEs	7
2.3	Monitoring Safety Performance: Frequency rate, severity rate	8,
2.4	Monitoring Safety Performance: incidence rate, activity rate.	9
2.5	Housekeeping: Responsibility of management and employees. Advantages of good housekeeping. 5 s of housekeeping.	10
2.6	Work permit system- objectives, hot work and cold work permits.	11
2.7	Typical industrial models and methodology. Entry into confined spaces.	12
3	Introduction to construction industry and safety	
3.1	Excavation and filling – Under-water works – Under-pinning & Shoring	13
3.2	Ladders & Scaffolds – Tunneling	14
3.3	Blasting –Demolition – Confined space	15
3.4	Familiarization with relevant Indian Standards and the National Building Code provisions on construction safety.	16
3.5	Relevance of ergonomics in construction safety.	17
3.6	Ergonomics Hazards	18
3.7	Musculoskeletal Disorders and Cumulative Trauma Disorders.	19
4	Machinery safeguard	

4.1	Point-of-Operation, Principle of machine guarding -	20
4.2	Types of guards and devices.	21
4.3	Safety in Power Presses, primary & secondary operations - shearing -bending - rolling – drawing.	22
4.4	Safety in turning, boring, milling, planning and grinding.	23
4.5	Welding and Cutting-Safety Precautions of Gas welding and Arc Welding,	24
4.6	Cutting and Finishing.	25
4.7	Material Handling-Classification-safety consideration- manual and mechanical handling. Handling assessments and techniques- lifting, carrying, pulling, pushing, palletizing and stocking.	26
4.8	Material Handling equipment-operation & maintenance. Maintenance of common elements-wire rope, chains slings, hooks, clamps	27
5	Hazard identification	
5.1	Hazard and risk, Types of hazards – Classification of Fire	28
5.2	Types of Fire extinguishers fire, explosion and toxic gas release.	29
5.3	Inventory analysis, Fire and explosion hazard rating of process plants -	30
5.4	The Dow Fire and Explosion Hazard Index.	31
5.5	Preliminary hazard analysis, Hazard and Operability study (HAZOP)	32
5.6	Chemical hazard- Classifications, Control of Chemical Hazards.	33
5.7	Hazardous properties of chemicals	34
5.8	Material Safety Data Sheets (MSDS).	35

ECL411	ELECTROMAGNETICS LAB	CATEGORY	L	T	P	CREDIT
		PCC	0	0	3	2

Preamble: This course aims to

- (i) Provide practical experience in design and analysis of few electronic devices and circuits used for Microwave and Optical communication engineering.
- (ii) Familiarize students with simulation of basic Antenna experiments with simulation tools.

Prerequisite: Nil

Course Outcomes: After the completion of the course the student will be able to

CO1	Familiarize the basic Microwave components and to analyse few microwave measurements and its parameters.
CO2	Understand the principles of fiber-optic communications and the different kind of losses, signal distortion and other signal degradation factors.
CO3	Design and simulate basic antenna experiments with simulation tools.

Mapping of course outcomes with program outcomes

	PO1	PO2	PO3	PO4	PO5	PO6	PO7	PO8	PO9	PO10	PO11	PO12
CO1	3	3	3						3			3
CO2	3	3	3						3			3
CO3	3	3	3	2	3				3			3

Assessment Mark distribution

Total Marks	CIE	ESE	ESE Duration
150	75	75	3 hours

Continuous Internal Evaluation Pattern:

Attendance	:	15 marks
Continuous Assessment	:	30 marks
Internal Test (Immediately before the second series test):	:	30 marks

End Semester Examination Pattern: The following guidelines should be followed regarding award of marks

- | | |
|---------------------------------------------------------------------------------|------------|
| (a) Preliminary work | : 15 Marks |
| (b) Implementing the work/ Conducting the experiment | : 10 Marks |
| (c) Performance, result and inference (usage of equipments and troubleshooting) | : 25 Marks |
| (d) Vivavoce | : 20 Marks |
| (e) Record | : 5 Marks |

General instructions: End-semester practical examination is to be conducted immediately after the second series test covering entire syllabus given below. Evaluation is to be conducted under the equal responsibility of both the internal and external examiners. The number of candidates evaluated per day should not exceed 20. Students shall be allowed for the examination only on submitting the duly certified record. The external examiner shall endorse the record.

Course Level Assessment Questions (Examples only):

Course Outcome 1 (CO1): Microwave Experiments

- 1) Verify the relation $\lambda_c = 2a$.
- 2) Find the unknown impedance of the given load using Transmission line equation and verify using Smith chart.
- 3) Compare the reflection coefficient of the given horn antenna and matched termination.
- 4) Find the coupling coefficient of the given Directional Coupler.
- 5) Plot Reflex Klystron repeller mode characteristics.
- 6) Find the threshold voltage of Gunn diode from its characteristics.

Course Outcome 2 (CO2): Optical Experiments

- 1) Find the numerical aperture and V number of the given fiber.
- 2) Obtain the bending loss and attenuation loss of the given fiber.
- 3) Plot the V-I characteristics of Laser diode.
- 4) Plot the V-I characteristics of LED.

List of Experiments:

I. MICROWAVE EXPERIMENTS (Minimum Four Experiments are mandatory)

1. Reflex Klystron Mode Characteristics.
2. GUNN diode characteristics.
3. VSWR and Frequency measurement.
4. Verify the relation between Guide wave length, free space wave length and cut off wave length for rectangular wave guide.

5. Unknown load impedance measurement using smith chart and verification using transmission line equation.
6. Measurement of Magic Tee characteristics.
7. Directional Coupler Characteristics.
8. Crystal Index Measurement.

II. OPTICAL EXPERIMENTS (Minimum Three Experiments are mandatory)

1. Setting up of Fiber optic Digital link.
2. Measurement of Numerical Aperture of a fiber.
3. Study of losses in Optical fiber.
4. Voltage vs. Current (V-I) characteristics of Laser Diode.
5. Voltage vs. Current (V-I) characteristics of LED.
6. Characteristics of Photodiode

III. ANTENNA EXPERIMENTS (Minimum Three Experiments are mandatory)

1. Familiarization of any antenna simulation software.
2. Simulation of Dipole Antenna.
3. Simulation of Patch Antenna.
4. Simulation of Antenna Array.
5. Study of Vector Network Analyzer.
6. Antenna Pattern Measurement

Text Books

1. Samuel Y. Liao, Microwave Devices and Circuits, 3/e, Pearson Education, 2003.
2. Gred Keiser Optical Fiber Communication 5/e Mc Graw Hill, 2013
3. Balanis, Antenna Theory and Design, 3/e, Wiley Publications.

References

1. John D. Krauss, Antennas for all Applications, 3/e, TMH.
2. Thomas A. Milligan, Modern Antenna Design, IEEE PRESS, 2/e, Wiley Inter science.
3. N.O. Sadiku and S.V. Kulkarni, *Principles of Electromagnetics*, Sixth Edition, Oxford University Press, India, 2015 (Asian adaptation of 'M.N.O. Sadiku, Elements of Electromagnetics, Sixth International Edition, Oxford University Press')

ECQ413	SEMINAR	CATEGORY	L	T	P	CREDIT
		PWS	0	0	3	2

Preamble: The course ‘Seminar’ is intended to enable a B.Tech graduate to read, understand, present and prepare report about an academic document. The learner shall search in the literature including peer reviewed journals, conference, books, project reports etc., and identify an appropriate paper/thesis/report in her/his area of interest, in consultation with her/his seminar guide. This course can help the learner to experience how a presentation can be made about a selected academic document and also empower her/him to prepare a technical report.

Course Objectives:

- To do literature survey in a selected area of study.
- To understand an academic document from the literature and to give a presentation about it.
- To prepare a technical report.

Course Outcomes [COs] : After successful completion of the course, the students will be able to:

CO1	Identify academic documents from the literature which are related to her/his areas of interest (Cognitive knowledge level: Apply).
CO2	Read and apprehend an academic document from the literature which is related to her/ his areas of interest (Cognitive knowledge level: Analyze).
CO3	Prepare a presentation about an academic document (Cognitive knowledge level: Create).
CO4	Give a presentation about an academic document (Cognitive knowledge level: Apply).
CO5	Prepare a technical report (Cognitive knowledge level: Create).

Mapping of course outcomes with program outcomes:

	PO1	PO2	PO3	PO4	PO5	PO6	PO7	PO8	PO9	PO10	PO11	PO12
CO1	2	2	1	1		2	1					3
CO2	3	3	2	3		2	1					3
CO3	3	2			3			1		2		3
CO4	3				2			1		3		3
CO5	3	3	3	3	2	2		2		3		3

Abstract POs defined by National Board of Accreditation			
PO#	Broad PO	PO#	Broad PO
PO1	Engineering Knowledge	PO7	Environment and Sustainability
PO2	Problem Analysis	PO8	Ethics
PO3	Design/Development of solutions	PO9	Individual and team work
PO4	Conduct investigations of complex problems	PO10	Communication
PO5	Modern tool usage	PO11	Project Management and Finance
PO6	The Engineer and Society	PO12	Life long learning

General Guidelines

- The Department shall form an Internal Evaluation Committee (IEC) for the seminar with academic coordinator for that program as the Chairperson/Chairman and seminar coordinator & seminar guide as members. During the seminar presentation of a student, all members of IEC shall be present.
- Formation of IEC and guide allotment shall be completed within a week after the University examination (or last working day) of the previous semester.
- Guide shall provide required input to their students regarding the selection of topic/paper.
- Choosing a seminar topic: The topic for a UG seminar should be current and broad based rather than a very specific research work. It's advisable to choose a topic for the Seminar to be closely linked to the final year project area. Every member of the project team could choose or be assigned Seminar topics that covers various aspects linked to the Project area.
- A topic/paper relevant to the discipline shall be selected by the student during the semester break.
- Topic/Paper shall be finalized in the first week of the semester and shall be submitted to the IEC.
- The IEC shall approve the selected topic/paper by the second week of the semester.
- Accurate references from genuine peer reviewed published material to be given in the report and to be verified.

Evaluation pattern

Total marks: 100, only CIE, minimum required to pass 50

Seminar Guide: 20 marks (Background Knowledge – 10 (The guide shall give deserving marks for a candidate based on the candidate's background knowledge about the topic selected), Relevance of the paper/topic selected – 10).

Seminar Coordinator: 20 marks (Seminar Diary – 10 (Each student shall maintain a seminar diary and the guide shall monitor the progress of the seminar work on a weekly basis and shall approve the entries in the seminar diary during the weekly meeting with the student), Attendance – 10).

Presentation: 40 marks to be awarded by the IEC (Clarity of presentation – 10, Interactions – 10 (to be based on the candidate's ability to answer questions during the interactive session of her/his presentation), Overall participation – 10 (to be given based on her/his involvement during interactive sessions of presentations by other students), Quality of the slides – 10).

Report: 20 marks to be awarded by the IEC (check for technical content, overall quality, templates followed, adequacy of references etc.).



ECD415	PROJECT PHASE I	CATEGORY	L	T	P	CREDIT
		PWS	0	0	6	2

Preamble: The course ‘Project Work’ is mainly intended to evoke the innovation and invention skills in a student. The course will provide an opportunity to synthesize and apply the knowledge and analytical skills learned, to be developed as a prototype or simulation. The project extends to 2 semesters and will be evaluated in the 7th and 8th semester separately, based on the achieved objectives. One third of the project credits shall be completed in 7th semester and two third in 8th semester. It is recommended that the projects may be finalized in the thrust areas of the respective engineering stream or as interdisciplinary projects. Importance should be given to address societal problems and developing indigenous technologies.

Course Objectives

- To apply engineering knowledge in practical problem solving.
- To foster innovation in design of products, processes or systems.
- To develop creative thinking in finding viable solutions to engineering problems.

Course Outcomes [COs] :After successful completion of the course, the students will be able to:

CO1	Model and solve real world problems by applying knowledge across domains (Cognitive knowledge level: Apply).
CO2	Develop products, processes or technologies for sustainable and socially relevant applications (Cognitive knowledge level: Apply).
CO3	Function effectively as an individual and as a leader in diverse teams and to comprehend and execute designated tasks (Cognitive knowledge level: Apply).
CO4	Plan and execute tasks utilizing available resources within timelines, following ethical and professional norms (Cognitive knowledge level: Apply).
CO5	Identify technology/research gaps and propose innovative/creative solutions (Cognitive knowledge level: Analyze).
CO6	Organize and communicate technical and scientific findings effectively in written and oral forms (Cognitive knowledge level: Apply).

Mapping of course outcomes with program outcomes

	PO1	PO2	PO3	PO4	PO5	PO6	PO7	PO8	PO9	PO10	PO11	PO12
CO1	2	2	2	1	2	2	2	1	1	1	1	2
CO2	2	2	2		1	3	3	1	1		1	1
CO3									3	2	2	1
CO4					2			3	2	2	3	2
CO5	2	3	3	1	2							1
CO6					2			2	2	3	1	1

Abstract POs defined by National Board of Accreditation			
PO#	Broad PO	PO#	Broad PO
PO1	Engineering Knowledge	PO7	Environment and Sustainability
PO2	Problem Analysis	PO8	Ethics
PO3	Design/Development of solutions	PO9	Individual and team work
PO4	Conduct investigations of complex problems	PO10	Communication
PO5	Modern tool usage	PO11	Project Management and Finance
PO6	The Engineer and Society	PO12	Lifelong learning

PROJECT PHASE I

Phase 1 Target

- Literature study/survey of published literature on the assigned topic
- Formulation of objectives
- Formulation of hypothesis/ design/ methodology
- Formulation of work plan and task allocation.
- Block level design documentation
- Seeking project funds from various agencies
- Preliminary Analysis/Modeling/Simulation/Experiment/Design/Feasibility study
- Preparation of Phase 1 report

Evaluation Guidelines & Rubrics

Total: 100 marks (Minimum required to pass: 50 marks).

- Project progress evaluation by guide: 30 Marks.
- Interim evaluation by the Evaluation Committee: 20 Marks.
- Final Evaluation by the Evaluation Committee: 30 Marks.
- Project Phase - I Report (By Evaluation Committee): 20 Marks.

(The evaluation committee comprises HoD or a senior faculty member, Project coordinator and project supervisor).

The guide/supervisor shall monitor the progress being carried out by the project groups on a regular basis. In case it is found that progress is unsatisfactory it shall be reported to the Department Evaluation Committee for necessary action. The presence of each student in the group and their involvement in all stages of execution of the project shall be ensured by the guide. Project evaluation by the guide: 30 Marks. This mark shall be awarded to the students in his/her group by considering the following aspects:

Topic Selection: innovativeness, social relevance etc. (2)

Problem definition: Identification of the social, environmental and ethical issues of the project problem. (2)

Purpose and need of the project: Detailed and extensive explanation of the purpose and need of the project. (3)

Project Objectives: All objectives of the proposed work are well defined; Steps to be followed to solve the defined problem are clearly specified. (2)

Project Scheduling & Distribution of Work among Team members: Detailed and extensive Scheduling with timelines provided for each phase of project. Work breakdown structure well defined. (3)

Literature survey: Outstanding investigation in all aspects. (4)

Student's Diary/ Daily Log: The main purpose of writing daily diary is to cultivate the habit of documenting and to encourage the students to search for details. It develops the students' thought process and reasoning abilities. The students should record in the daily/weekly activity diary the day to day account of the observations, impressions, information gathered and suggestions given, if any. It should contain the sketches & drawings related to the observations made by the students. The daily/weekly activity diary shall be signed after every day/week by the guide. (7)

Individual Contribution: The contribution of each student at various stages. (7)

EVALUATION RUBRICS for PROJECT Phase I: Interim Evaluation

No.	Parameters	Marks	Poor	Fair	Very Good	Outstanding
1-a	Topic identification, selection, formulation of objectives and/or literature survey. (Group assessment) [CO1]	10	The team has failed to come with a relevant topic in time. Needed full assistance to find a topic from the guide. They do not respond to suggestions from the evaluation committee and/or the guide. No literature review was conducted. The team tried to gather easy information without verifying the authenticity. No objectives formed yet.	The team has identified a topic. The originally selected topic lacks substance and needs to be revised. There were suggestions given to improve the relevance and quality of the project topic. Only a few relevant references were consulted/ studied and there is no clear evidence to show the team's understanding on the same. Some objectives identified, but not clear enough.	Good evidence of the group thinking and brainstorming on what they are going to build. The results of the brainstorming are documented and the selection of topic is relevant. The review of related references was good, but there is scope of improvement. Objectives formed with good clarity, however some objectives are not realistic enough.	The group has brainstormed in an excellent manner on what they were going to build. The topic selected is highly relevant, real world problem and is potentially innovative. The group shows extreme interest in the topic and has conducted extensive literature survey in connection with the topic. The team has come up with clear objectives which are feasible.
			(0 – 3 Marks)	(4 – 6 Marks)	(7 - 9 Marks)	(10 Marks)
1-b	Project Planning, Scheduling and Resource/ Tasks Identification and allocation. (Group assessment) [CO4]	10	No evidence of planning or scheduling of the project. The students did not plan what they were going to build or plan on what materials / resources to use in the project. The students do not have any idea on the budget required. The team has not yet decided on who does what. No project journal kept.	Some evidence of a primary plan. There were some ideas on the materials /resources required, but not really thought out. The students have some idea on the finances required, but they have not formalized a budget plan. Schedules were not prepared. The project journal has no details. Some evidence on task allocation among the team members.	Good evidence of planning done. Materials were listed and thought out, but the plan wasn't quite complete. Schedules were prepared, but not detailed, and needs improvement. Project journal is presented but it is not complete in all respect / detailed. There is better task allocation and individual members understand about their tasks. There is room for improvement.	Excellent evidence of enterprising and extensive project planning. Gantt charts were used to depict detailed project scheduling. A project management/version control tool is used to track the project, which shows familiarity with modern tools. All materials / resources were identified and listed and anticipation of procuring time is done. Detailed budgeting is done. All tasks were identified and incorporated in the schedule. A well-kept project journal shows evidence for all the above, in addition to the interaction with the project guide. Each member knows well about their individual tasks.
			(0 – 3 Marks)	(4 – 6 Marks)	(7 - 9 Marks)	(10 Marks)
Phase 1 Interim Evaluation Total Marks: 20						

EVALUATION RUBRICS for PROJECT Phase I: Final Evaluation

Sl. No.	Parameters	Marks	Poor	Fair	Very Good	Outstanding
1-c	Formulation of Design and/or Methodology and Progress. (Group assessment) [CO1]	5	None of the team members show any evidence of knowledge about the design and the methodology adopted till now/ to be adopted in the later stages. The team has not progressed from the previous stage of evaluation.	The students have some knowledge on the design procedure to be adopted, and the methodologies. However, the team has not made much progress in the design, and yet to catch up with the project plan.	The students are comfortable with design methods adopted, and they have made some progress as per the plan. The methodologies are understood to a large extent.	Shows clear evidence of having a well- defined design methodology and adherence to it. Excellent knowledge in design procedure and its adaptation. Adherence to project plan is commendable.
			(0 – 1 Marks)	(2 – 3 Marks)	(4 Marks)	(5 Marks)
1-d	Individual and Teamwork Leadership (Individual assessment) [CO3]	10	The student does not show any interest in the project activities, and is a passive member.	The student show some interest and participates in some of the activities. However, the activities are mostly easy and superficial in nature.	The student shows very good interest in project, and takes up tasks and attempts to complete them. Shows excellent responsibility and team skills. Supports the other members well.	The student takes a leadership position and supports the other team members and leads the project. Shows clear evidence of leadership.
			(0 – 3 Marks)	(4 – 6 Marks)	(7 - 9 Marks)	(10 Marks)
1-e	Preliminary Analysis/ Modeling / Simulation/ Experiment / Design/ Feasibility study [CO1]	10	The team has not done any preliminary work with respect to the analysis/modeling/ simulation/experiment/design/feasibility study/ algorithm development.	The team has started doing some preliminary work with respect to the project. The students however are not prepared enough for the work and they need to improve a lot.	There is some evidence to show that the team has done good amount of preliminary investigation and design/ analysis/ modeling etc. They can improve further.	Strong evidence for excellent progress in the project. The team has completed the required preliminary work already and are poised to finish the phase I in an excellent manner. They have shown results to prove their progress.
			(0 – 3 Marks)	(4 – 6 Marks)	(7 - 9 Marks)	(10 Marks)

1-f	Documentation and presentation. (Individual & group assessment). [CO6]	5	<p>The team did not document the work at all. The project journal/diary is not presented. The presentation was shallow in content and dull in appearance. The individual student has no idea on the presentation of his/her part.</p>	<p>Some documentation is done, but not extensive. Interaction with the guide is minimal. Presentation include some points of interest, but overall quality needs to be improved. Individual performance to be improved.</p>	<p>Most of the project details were documented well enough. There is scope for improvement. The presentation is satisfactory. Individual performance is good.</p>	<p>The project stages are extensively documented in the report. Professional documentation tools like LaTeX were used to document the progress of the project along with the project journal. The documentation structure is well-planned and can easily grow into the project report.</p> <p>The presentation is done professionally and with great clarity. The individual's performance is excellent.</p>
			(0 – 1 Marks)	(2 – 3 Marks)	(4 Marks)	(5 Marks)
Total		30	Phase - I Final Evaluation Marks: 30			

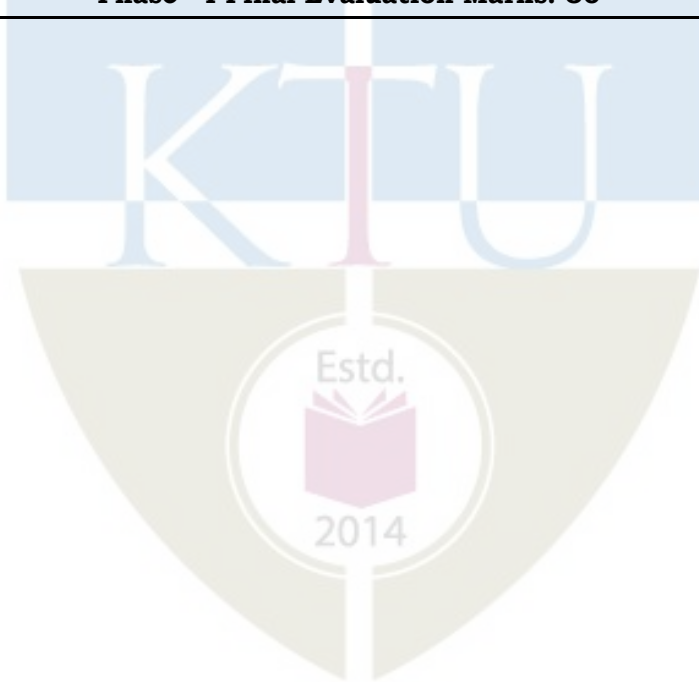

EVALUATION RUBRICS for PROJECT Phase I: Report Evaluation

Sl. No.	Parameters	Marks	Poor	Fair	Very Good	Outstanding
1-g	Report [CO6]	20	The prepared report is shallow and not as per standard format. It does not follow proper organization. Contains mostly Unacknowledged content. Lack of effort in preparation is evident.	Project report follows the standard format to some extent. However, its organization is not very good. Language needs to be improved. All references are not cited properly in the report.	Project report shows evidence of systematic documentation. Report is following the standard format and there are only a few issues. Organization of the report is good. Most of references are cited properly.	The report is exceptionally good. Neatly organized. All references cited properly. Diagrams/Figures, Tables and equations are properly numbered, and listed and clearly shown. Language is excellent and follows standard styles.
			(0 - 7 Marks)	(8 - 12 Marks)	(13 - 19 Marks)	(20 Marks)
Phase - I Project Report Marks: 20						

