

APJ ABDUL KALAM  
TECHNOLOGICAL  
UNIVERSITY

# **SEMESTER VI**

KTU



ECT302	ELECTROMAGNETICS	CATEGORY	L	T	P	CREDIT
		PCC	3	1	0	4

**Preamble:** This course aims to impart knowledge on the basic concepts of electric and magnetic fields and its applications.

**Prerequisite:** MAT102 Vector Calculus

**Course Outcomes:** After the completion of the course the student will be able to

CO 1 K2	To summarize the basic mathematical concepts related to electromagnetic vector fields.
CO 2 K3	Analyse Maxwell's equation in different forms and apply them to diverse engineering problems.
CO3 K3	To analyse electromagnetic wave propagation and wave polarization
CO4 K3	To analyse the characteristics of transmission lines and solve the transmission line problems using Smith chart.
CO5 K3	To analyse and evaluate the propagation of EM waves in Wave guides.

**Mapping of course outcomes with program outcomes**

	PO 1	PO 2	PO 3	PO 4	PO 5	PO 6	PO 7	PO 8	PO 9	PO 10	PO 11	PO 12
CO1	3	3	1	1								2
CO2	3	3	1	1								2
CO3	3	3	1	1								2
CO4	3	3	1	1								2
CO5	3	3	1	1								2

**Assessment Pattern**

Bloom's Category		Continuous Assessment Tests		End Semester Examination
		1	2	
Remember	K1			
Understand	K2	20	20	40
Apply	K3	30	30	60
Analyse				
Evaluate				
Create				

**Mark distribution**

Total Marks	CIE	ESE	ESE Duration
150	50	100	3 hours

**Continuous Internal Evaluation Pattern:**

Attendance	: 10 marks
Continuous Assessment Test (2 numbers)	: 25 marks
Assignment/Quiz/Course project	: 15 marks

**End Semester Examination Pattern:** There will be two parts; Part A and Part B. Part A contain 10 questions with 2 questions from each module, having 3 marks for each question. Students should answer all questions. Part B contains 2 questions from each module of which student should answer any one. Each question can have maximum 2 sub-divisions and carry 14 marks.

**Course Level Assessment Questions**

**Course Outcome 1 (CO1): To summarize the basic mathematical concepts related to electromagnetic vector fields. (K2)**

1. State and explain divergence theorem. Give a geometrical explanation.
2. Find the curl of the vector  $A = 2r\cos\phi a_\rho + r a_\phi$  in cylindrical coordinates
3. Show that  $\text{curl grad } F$  and  $\text{div curl } F$  are identically zero.
4. Show that  $V = \frac{1}{4\pi\epsilon_0} \frac{Q}{r}$  where  $r = (x^2 + y^2 + z^2)^{1/2}$  satisfies Laplace's equation.

**Course Outcome 2 (CO2): Analyse Maxwell's equation in different forms and apply them to diverse engineering problems. (K3)**

1. State and explain Maxwell's equations in the integral and differential forms.
2. Derive the solution of uniform plane wave in lossy dielectric medium.

**Course Outcome 3 (CO3): To analyse electromagnetic wave propagation and wave polarization (K3)**

1. Derive an expression for reflection coefficient of a plane wave under oblique incidence with parallel polarization at a dielectric interface.

2. Explain wave polarization and different polarisation with example.
3. Derive the expression for Brewster angle for parallel polarised wave.

**Course Outcome 4 (CO4): To analyse the characteristics of transmission lines and solve the transmission line problems using Smith chart. (K3)**

1. A transmission line of length  $0.2 \lambda$  and characteristic impedance  $100\Omega$  is terminated with a load impedance of  $50+200j$ . Find input impedance, reflection coefficient at load end, reflection coefficient at the input end and VSWR.
2. A lossless transmission line has a characteristic impedance of  $50\Omega$  and phase constant of  $3 \text{ Rad/m}$  at  $100 \text{ MHz}$ . Find Inductance per meter and Capacitance per meter of the transmission line.
3. A  $50 + j200 \Omega$  load is connected to a  $100\Omega$  lossless transmission line. Using Smith chart, find i. Reflection coefficient at load ii. VSWR

**Course Outcome 5 (CO5): To analyse and evaluate the propagation of EM waves in Wave guides.(K3)**

1. For TE<sub>10</sub> mode of propagation in a rectangular wave guide, with length  $8\text{cm}$  and  $6 \text{ cm}$  respectively, find the following when frequency of operation is  $6 \text{ GHz}$ .
  - i. Cut off frequency
  - ii. Cut off wavelength
  - iii. Guide wavelength
  - iv. Phase constant
  - v. Phase velocity
  - vi. Group velocity
  - vii. Wave impedance
2. A rectangular wave guide has a dimension of  $3\text{cm} \times 5\text{cm}$ , and is operating at a frequency of  $10 \text{ GHz}$ . Calculate the cutoff wavelength, cutoff frequency, guide wavelength, phase velocity and group velocity. and the wave impedance for TE<sub>10</sub> mode.
3. Derive the expression for Electric and magnetic field intensities for TM mode of propagation of rectangular waveguide.

**SYLLABUS****MODULE 1 :**

Introduction to Electromagnetic Theory. Review of vector calculus- curl, divergence gradient. Rectangular, cylindrical and spherical coordinate systems. Expression of curl divergence and Laplacian in cartesian, cylindrical and spherical coordinate system. Electric field and magnetic field, Review of Coulomb's law, Gauss law and Amperes current law. Poisson and Laplace equations, Determination of E and V using Laplace equation.

**MODULE 2 :**

Derivation of capacitance and inductance of two wire transmission line and coaxial cable. Energy stored in Electric and Magnetic field. Displacement current density, continuity equation. Magnetic vector potential. Relation between scalar potential and vector potential. Maxwell's equation from fundamental laws. Boundary condition of electric field and magnetic field from Maxwells equations. Solution of wave equation.

**MODULE 3 :**

Propagation of plane EM wave in perfect dielectric, lossy medium, good conductor, media-attenuation, phase velocity, group velocity, skin depth. Reflection and refraction of plane electromagnetic waves at boundaries for normal & oblique incidence (parallel and perpendicular polarization), Snell's law of refraction, Brewster angle.

**MODULE 4 :**

Power density of EM wave, Poynting vector theorem. Polarization of electromagnetic wave- linear, circular and elliptical polarisation. Uniform lossless transmission line - line parameters. Transmission line equations, Voltage and Current distribution of a line terminated with load .Reflection coefficient and VSWR. Derivation of input impedance of transmission line.

**MODULE 5 :**

Transmission line as circuit elements (L and C). Development of Smith chart - calculation of line impedance and VSWR using smith chart.

The hollow rectangular wave guide –modes of propagation of wave-dominant mode, group velocity and phase velocity -derivation and simple problems only

**Text Books**

1. John D. Kraus, Electromagnetics, 5/e, TMH, 2010.
2. Mathew N O Sadiku, Elements of Electromagnetics, Oxford University Press, 6/e, 2014.
3. William, H. Hayt, and John A. Buck. Engineering Electromagnetics. McGraw-Hill, 8/e McGraw-Hill, 2014.

**Reference Books**

1. Edminister, “Schaum’s Outline of Electromagnetics”, 4/e, McGraw-Hill, 2014.
2. Jordan and Balmain , Electromagnetic waves and Radiating Systems, PHI, 2/e,2013
3. Martin A Plonus , Applied Electromagnetics, McGraw Hill, 2/e,1978.
4. Nannapaneni Narayana Rao, Elements of Engineering Electromagnetics, Pearson, 6/e, 2006.
5. Umran S. Inan and Aziz S. Inan, Engineering Electromagnetics, Pearson, 2010.

**Course Contents and Lecture Schedule**

No	Topic	No. of Lectures
<b>1</b>	<b>Module 1</b>	
1.1	Introduction to Electromagnetic Theory. Review of vector calculus- curl, divergence gradient.	3
1.2	Rectangular, cylindrical and spherical coordinate systems. Expression of curl divergence and Laplacian in cartesian , cylindrical and spherical coordinate system.	3
1.3	Electric field and magnetic field. Review of Coulomb’s law , Gauss law and Amperes current law.	2
1.4	Poisson and Laplace equations, Determination of E and V using Laplace equation.	2
<b>2</b>	<b>Module 2</b>	
2.1	Derivation of capacitance and inductance of two wire transmission line and coaxial cable.	2
2.2	Energy stored in Electric and Magnetic field.	1
2.3	Displacement current density, continuity equation. Magnetic vector potential. Relation between scalar potential and vector potential.	3
2.4	Maxwell’s equation from fundamental laws.	2
	Boundary condition of electric field and magnetic field from Maxwell’s equations.	1
2.5	Solution of wave equation	1
<b>3</b>	<b>Module 3</b>	
3.1	Propagation of plane EM wave in perfect dielectric, lossy medium, good conductor, media-attenuation, phase velocity, group velocity, skin depth.	4
3.2	Reflection and refraction of plane electromagnetic waves at boundaries for normal & oblique incidence (parallel and perpendicular polarization), Snell’s law of refraction, Brewster angle.	4
<b>4</b>	<b>Module 4</b>	

4.1	Power density of EM wave, Poynting vector theorem.	2
4.2	Polarization of electromagnetic wave-linear, circular and elliptical polarisation.	2
4.3	Uniform lossless transmission line - line parameters. Transmission line equations	3
4.4	Voltage and Current distribution of a line terminated with load .Reflection coefficient and VSWR.Derivation of input impedance of transmission line.	3
<b>5</b>	<b>Module 5</b>	
5.1	Transmission line as circuit elements (L and C).	1
5.2	Development of Smith chart - calculation of line impedance and VSWR using smith chart.	3
5.3	The hollow rectangular wave guide –modes of propagation of wave-dominant mode, group velocity and phase velocity -derivation and simple problems only	4

**Assignments:****Model Question paper****APJ ABDUL KALAM TECHNOLOGICAL UNIVERSITY**

SIXTH SEMESTER B.TECH DEGREE EXAMINATION, (Model Question Paper)

**Course Code: ECT302****Course Name: ELECTROMAGNETICS**

Max. Marks: 100

Duration: 3 Hours

**PART A**

Answer ALL Questions. Each Carries 3 mark.

- 1 Define Curl of a vector field. Explain its physical significance. K2
- 2 Obtain Coulomb's law from Gauss' law K2
- 3 Write Poisson's and Laplace's Equation with applications K1
- 4 A Parallel plate capacitor with plate area of  $5\text{cm}^2$  and a plate separation of 3mm K3  
has a voltage  $50\sin 10^3 t$  Volt applied to its plates. Calculate the displacement current assuming  $\epsilon = 2\epsilon_0$ .
- 5 List all Maxwell's equations in integral form K1

- 6 Explain the significance of skin depth. K2
- 7 What is Snell's law? K1
- 8 What is wave polarisation? What are the different types of polarisation? K1
- 9 State the relation between standing wave ratio and reflection coefficient. K1
- 10 How a quarter wave dissipationless line can be used for impedance matching?. K2

**PART – B**

Answer one question from each module; each question carries 14 marks.

**Module - I**

- 11 a. Derive the equation for curl of a vector field in Cartesian co-ordinate system. 7  
CO1  
K2
- b. A Spherical volume charge distribution is given by 7  

$$\rho = \rho_0 \left(1 - \frac{r^2}{a^2}\right); r \leq a$$

$$\rho = 0; r > a$$
 Find the electric field intensity E; i) inside and ii) outside the charge distribution CO1  
K3

**OR**

- 12 Interpret the following 7  
CO1  
K3
- i)  $\nabla \times B = \mu_0 J$  ii)  $\nabla \times E = 0$  where B and J stands for magnetic flux density and electric current density
- b. Apply Ampere's circuital law to the case of an infinitely long coaxial cable carrying a uniformly distributed total current I. Compute the magnetic field intensity existing in different parts of the cable. 7  
CO1  
K3

**Module - II**

- 13 a. Derive the expression of capacitance of two wire transmission line. 7  
CO2  
K2
- b. Show that the energy stored in a system of n point charges is given by 7



$$W_E = \frac{1}{2} \sum_{i=1}^n Q_i V_i \text{ where } V_i \text{ is the potential of the point charge } Q_i.$$

CO2

K3

**OR**

- 14a Define vector magnetic potential and show that  $B = \nabla \times A$ , where B is the magnetic flux density and A is the vector magnetic potential at any point. 7  
CO2  
K2

- b State and prove boundary conditions for E and H in accordance with Maxwell's equations. 7  
CO2  
K2

**Module - III**

- 15 Derive the expression for reflection coefficient for a wave of perpendicular polarization, travelling from one medium to another at oblique incidence. 7  
a. CO3  
K2

- b. In a lossy dielectric medium, characteristic impedance of the medium is  $173 + j100 \Omega$ , Expression of Magnetic field of a plane wave is given by  $10 e^{-\alpha x} \cos(\omega t - 0.5x) a_z$  A/m. Find 7  
CO3  
K3

i. Direction of propagation

ii. Loss tangent

iii. Attenuation constant

iv. Phase constant

v. Skin depth

**OR**

- 16 a Derive continuity equation from fundamental laws. 7  
CO3  
K2

- b Find the skin depth,  $\delta$  at a frequency of 1.6 MHz in aluminium, where  $\sigma=38.2 \text{MS/m}$  and  $\mu_r=1$ . Also find the propagation constant,  $\gamma$  and the wave

		7
velocity $v$ .		CO3
		K3

#### Module - IV

- 17a Derive the equation for transmission and reflection coefficients of an electromagnetic wave incident normally on the boundary between two different regions. 7  
CO4  
K2
- b Derive an expression for net outward power flow associated with an electromagnetic wave, from a surface. 7  
CO4  
K2

#### OR

- 18 Derive standard Transmission line equations. 7  
a. CO4  
K2
- b. Given two dielectric media, the first medium is free space and the second medium has  $\epsilon_2 = 4\epsilon_0$  and  $\mu = \mu_0$ . Find the reflection coefficient for oblique incidence at  $\theta_1 = 30^\circ$  for i) perpendicular polarisation and ii) parallel polarisation 7  
CO4  
K3

#### Module - V

- 19 A rectangular wave guide has a dimension of 3cm x 5cm , and is operating at a 7  
a. frequency of 10 GHz . Calculate the cutoff wavelength, cutoff frequency , guide CO5  
wavelength , phase velocity and group velocity . and the wave impedance for K3  
TE10 mode.
- b. At a frequency of 80 MHz, a lossless transmission line has a characteristic 7  
impedance of  $300\Omega$  and a wavelength of 2.5m. Find: CO5  
i) L ii) C iii) If the line is terminated with a parallel combination of  $200\Omega$   
and 5pF, determine the reflection co-efficient and the standing wave ratio. K3

#### OR

- 20 a A  $50 + j200 \Omega$  load is connected to a  $100\Omega$  lossless transmission line . Using smith 7  
chart , find

- |                                   |  |                      |     |
|-----------------------------------|--|----------------------|-----|
| i. Reflection coefficient at load | ii. VSWR   | iii. Load admittance | CO5 |
|                                   |  |                      | K3  |
| b                                 | Derive the expression for Electric and magnetic field intensities for TM mode of propagation of rectangular waveguide. |                      | 7   |
|                                   |  |                      | CO5 |

K2

APJ ABDUL KALAM  
TECHNOLOGICAL  
UNIVERSITY

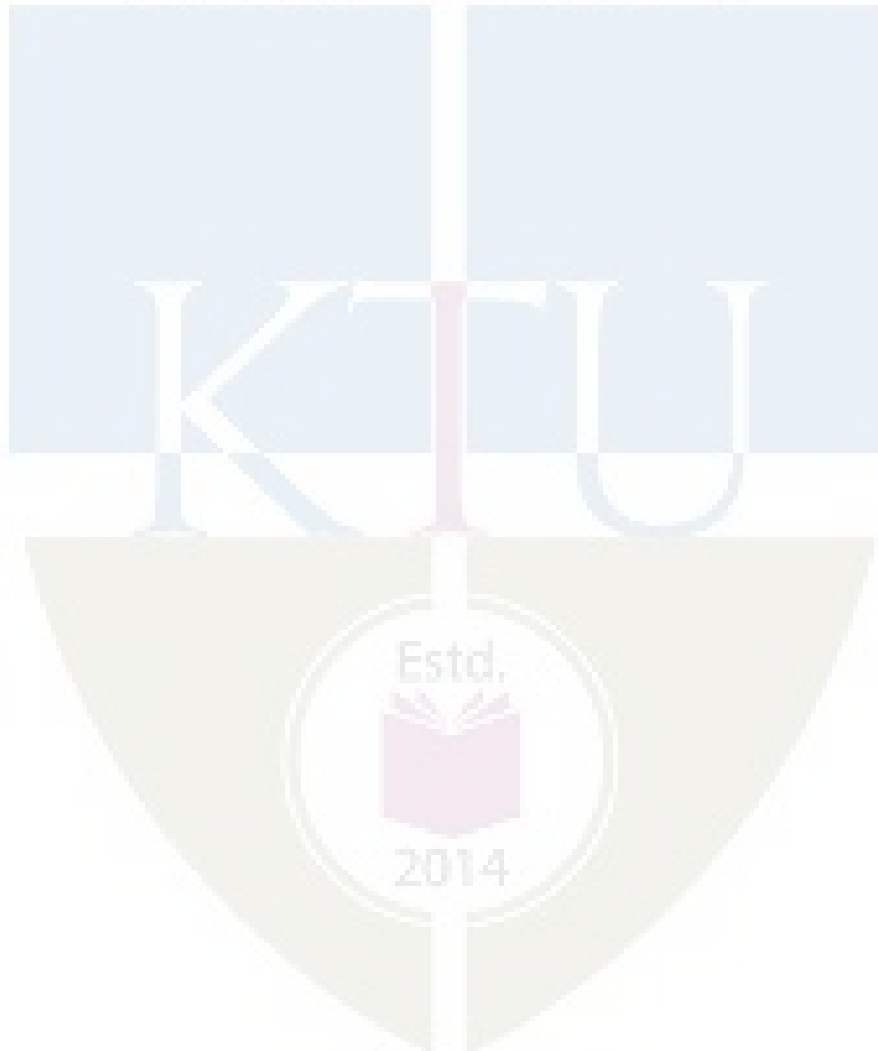

ECT304	VLSI CIRCUIT DESIGN	CATEGORY	L	T	P	CREDIT
		PCC	3	1	0	4

**Preamble:** This course aims to impart the knowledge of VLSI design methodologies and Digital VLSI circuit design.

**Prerequisite:**

1. ECT201 Solid State Devices
2. ECT202 Analog Circuits
3. ECT 203 Logic Circuit Design.

**COURSE OUTCOMES.**

After the completion of the course the student will be able to:

CO1	Explain the various methodologies in ASIC and FPGA design.
CO2	Design VLSI Logic circuits with various MOSFET logic families.
CO3	Compare different types of memory elements.
CO4	Design and analyse data path elements such as Adders and multipliers.
CO5	Explain MOSFET fabrication techniques and layout design rules.

**Mapping of course outcomes with program outcomes:**

	PO1	PO2	PO3	PO4	PO5	PO6	PO7	PO8	PO9	PO10	PO11	PO12
CO1	3		3									2
CO2	3	2	3									2
CO3	3	2	3									2
CO4	3	2	3									2
CO5	3		2									2

**Assessment Pattern:**

Bloom's Category	Continuous Assessment Tests		End Semester Examination
	1	2	
Remember	10	10	20
Understand	20	20	40
Apply	20	20	40
Analyze			
Evaluate			
Create			

**Mark distribution:**

Total Marks	CIE	ESE	Duration
150	50	100	3Hrs

**Continuous Internal Evaluation Pattern:**

Attendance : 10 marks  
 Continuous Assessment Test (2 numbers) : 25 marks  
 Assignments : 15 marks.

**End Semester Examination Pattern****Maximum Marks : 100****Time : 3 hours**

**End Semester Examination Pattern:** There will be two parts; Part A and Part B. Part A contain 10 questions with 2 questions from each module, having 3 marks for each question. Students should answer all questions. Part B contains 2 questions from each module of which student should answer any one. Each question can have maximum 2 sub-divisions and carry 14 marks. Mark patterns are as per the syllabus with 75% for theory and 25% for logical/numerical problems.

**Course Level Assessment Questions.****CO1:**

1. Differentiate between full custom and semi-custom ASIC.
2. With a neat flow chart, explain ASIC design flow.
3. Describe Gate array based ASIC with neat diagram.
4. What are the processes involved in Soc design.

**CO2:**

1. With a neat diagram explain static and transient analysis of CMOS inverter
2. Realize the given logic function using static CMOS logic and transmission gate logic.
3. Compare the advantages and disadvantages of static and dynamic circuits.

**CO3:**

1. Compare different ROM structures.
2. Compare static and dynamic RAM structures.
3. Compare the advantages of three transistor and one transistor DRAM cell.

**CO4:**

1. Design a full adder with static CMOS logic
2. Compare the delay of Carry-Bypass adder, Linear Carry- Select adder, Square- root carry-select adder.

**CO5:**

1. Explain how electronic grade silicon (EGS) is developed .
2. Explain the necessity of single crystalline silicon in VLSI fabrication and how single crystal silicon is made.
3. Explain diffusion and ion implantation techniques.
4. Explain the advantages of SiO<sub>2</sub> and the oxidation techniques.

**Syllabus****Module 1: VLSI Design Methodologies.**

Introduction: Moore's law .ASIC design, Full custom ASICs, Standard cell based ASICs, Gate array based ASICs, SoCs, FPGA devices, ASIC and FPGA Design flows, Top-Down and Bottom-Up design methodologies. Logical and Physical design. Speed power and area considerations in VLSI design

**Module 2: Static CMOS Logic Design**

**MOSFET Logic Design** - NMOS Inverter (Static analysis only), basic logic gates, CMOS logic, Static and transient analysis of CMOS inverter, Switching power dissipation and delays. Realization of logic functions with static CMOS logic, Pass transistor logic, and transmission gate logic

**Module 3: Dynamic logic Design and Storage Cells**

Dynamic Logic Design-Pre charge- Evaluate logic, Domino Logic, NP domino logic.

**Read Only Memory**-4x4 MOS ROM Cell Arrays(OR,NOR,NAND)

**Random Access Memory** –SRAM-Six transistor CMOS SRAM cell, DRAM –Three transistor and One transistor Dynamic Memory Cell.

**Module 4: Arithmetic circuits**

**Adders:** Static adder, Carry-Bypass adder, Linear Carry- Select adder, Square- root carry- select adder. **Multipliers:** Array multiplier.

**Module 5: Fabrication techniques and MOSFET physical Design****Material Preparation**

Purification and Crystal growth (CZ process), wafer preparation

**Thermal Oxidation-** Growth mechanisms, Dry and Wet oxidation.

Diffusion and ion implantation techniques.

**Epitaxy :** molecular beam epitaxy.

**Lithography-** Photo lithographic sequence, Electron Beam Lithography, Etching and metal deposition techniques.

**MOSFET Fabrication techniques**

Twin-Tub fabrication sequence, Fabrication process flow.

**Layout Design and Design rules,** Stick Diagram and Design rules-micron rules and Lambda rules. (definitions only).layout of CMOS Inverter, two input NAND and NOR gates.

**Text Books:**

1. Sung –Mo Kang & Yusuf Leblebici, CMOS Digital Integrated Circuits- Analysis & Design, McGraw-Hill, Third Ed., 2003
2. S.M. SZE, VLSI Technology, 2/e, Indian Edition, McGraw-Hill,2003
3. Wayne Wolf ,Modern VLSI design, Third Edition, Pearson Education,2002.

**References:**

1. Michael John Sebastian Smith, Application Specific Integrated Circuits, Pearson Education,2001.
2. Neil H.E. Weste, Kamran Eshraghian, Principles of CMOS VLSI Design- A Systems Perspective, Second Edition. Pearson Publication, 2005.
3. Jan M. Rabaey, Digital Integrated Circuits- A Design Perspective, Prentice Hall, Second Edition, 2005.
4. Razavi - Design of Analog CMOS Integrated Circuits,1e, McGraw Hill Education India Education, New Delhi, 2003.
- 5.

**Course Contents and Lecture Schedule.**

No	Topic	No. of Lectures
<b>Module 1: VLSI Design Methodologies. (11 Hrs)</b>		
1.1	Introduction: Moore slaw .ASIC design, Full custom ASICs, Standard cell based ASICs, Gate array based ASICs,	3
1.2	SoCs, FPGA devices	2
1.3	ASIC and FPGA Design flows Top-Down and Bottom-Up design methodologies.	3
1.4	Logical and Physical design. Speed power and area considerations in VLSI design	3
<b>Module 2:Static CMOS Logic Design (9 Hrs)</b>		
2.1	<b>MOSFET Logic Design</b> - NMOS logic (Static analysis of Basic gates only)	3
2.2	CMOS logic, Static and transient analysis of CMOS inverter Switching power dissipation and delays	3
2.3	Realization logic functions in static CMOS logic, Pass transistor logic, and transmission gate logic (Static analysis only)	3
<b>Module 3: Dynamic logic Design and Storage Cells (8 Hrs)</b>		
3.1	Dynamic Logic Design-Pre charge- Evaluate logic, Domino Logic, NP domino logic.	3

3.2	<b>Read Only Memory</b> -4x4 MOS ROM Cell Arrays(OR,NOR,NAND)	2
3.3	<b>Random Access Memory</b> –SRAM-Six transistor CMOS SRAM cell, DRAM –Three transistor and One transistor Dynamic Memory Cell.	3
<b>Module 4: Arithmetic circuits (5 Hrs)</b>		
4.1	<b>Adders</b> - Static adder, Carry-Bypass adder, Linear Carry- Select adder, Square- root carry- select adder.	3
4.2	<b>Multipliers</b> -Array multiplier.	2
<b>Module 5: MOSFET physical Design and Fabrication techniques (13 Hrs)</b>		
5.1	<b>Material Preparation</b> (qualitative analysis only) Purification and Crystal growth (CZ process), wafer preparation.	2
5.2	<b>Thermal Oxidation</b> - Growth mechanisms, Dry and Wet oxidation. Diffusion and ion implantation techniques.	3
5.3	<b>Epitaxy</b> : Molecular beam epitaxy. <b>Lithography</b> - Photo lithographic sequence, Electron Beam Lithography, Etching and metal deposition techniques	3
5.4	<b>MOSFET Fabrication techniques</b> ( <i>qualitative analysis only</i> ) Twin-Tub fabrication sequence, Fabrication process flow.	2
5.5	<b>Layout Design and Design rules</b> , Stick Diagram and Design rules- micron rules and Lambda rules. Layout of CMOS Inverter, two input NAND and NOR gates,	3



**Model Question Paper****A P J Abdul Kalam Technological University**

Sixth Semester B Tech Degree Examination

Branch: Electronics and Communication Course:

**ECT 304 VLSI CIRCUIT DESIGN**

Time: 3 Hrs Max.

Marks: 100

**PART A***(Answer All Questions)*

- 1 What is Moore's law in VLSI design? (3)
- 2 Differentiate between ASIC and FPGA. (3)
- 3 Switching threshold voltage equation of CMOS inverter and explain each parameter (3)
- 4 List the advantage of CMOS logic. (3)
- 5 List the advantages of dynamic logic over static logic circuits. (3)
- 6 Differentiate between volatile and non volatile memories. (3)
- 7 Explain propagate delay and generate signals. (3)
- 8 What are the different types of power dissipation in a CMOS inverter? (3)
- 9 List the advantages of SiO<sub>2</sub> (3)
- 10 Define lambda rules and micron rules. (3)

**PART B***(Answer one question from each module. Each question carries 14 mark.)*

- 11(A) What is FPGA? What are its applications? With block diagram explain its internal architecture? (6)
  - 11(B) Explain ASIC design flow. (8)
- OR
- 12(A) Compare different ASIC design methodologies. (8)
  - 12(A) List the advantages of SOC (6)
- 13(A) Derive expression for the switching threshold of a CMOS inverter. (7)
  - 13(B) What is meant by pass transistor logic? What are the differences in transmission characteristics of N MOS and P MOS transistors? (7)
- OR
- 14(A) What are the different types of power dissipation in a CMOS inverter? Derive expression for the total power dissipation. (8)
  - 14(B) Why PMOS transistor can pass only strong ones and NMOS can pass strong zeros. (6)

- 15(A) Draw the circuit diagram and explain the principle of operation of a CMOS based static RAM cell. Explain the read and write operations. What are the constraints on the sizes of transistors? (7)
- 15(B) Draw the circuit diagram and explain the principle of operation of a one transistor dynamic RAM cell. Explain the read, write and refresh operations (7)
- OR
- 16(A) Explain the read and write operation of a three-transistor DRAM cell (7)
- 16(B) Explain the read and write operation of a six transistor CMOS SRAM cell. (7)
- OR
- 17(A) With diagram illustrate the principle of operation of an array multiplier. Show the critical path. Estimate the delay of the multiplier. (8)
- 17(B) With block diagram illustrate the principle of operation of a square root carry select adder. Estimate the delay of an n bit adder (6)
- OR
- 18(A) Draw circuit diagram of a full adder with not more than 28 transistors in standard CMOS logic (8)
- 18(B) Explain the working a 16-bit carry-by pass adder and write down the expression for worst-case delay. (6)
- 19(A) Illustrate with diagram the principle of crystal growth by Czochralzki method. (7)
- 19(B) What is photolithography? With diagram illustrate the steps involved in photolithography process. (7)
- OR
- 20(A) Explain the principle of molecular beam epitaxy, with schematic diagram of an MBE system. What are its advantages and disadvantages? (8)
- 20(B) With schematic diagram and chemical reactions involved, illustrate wet and dry oxidation processes (6)

**MODEL ASSIGNMENT QUESTIONS****Module 1**

1. How to choose between FPGA and ASIC ?
2. Describe ASIC in terms of Size, power and performance, IP protection and competitive Edge
3. Compare Gate-array design and Full-custom design?
4. What are the differences between CPLDs and CLBs
5. List some of the commonly used FPGA development board ?
6. Discuss the architecture of any one of the leading FPGA in industry ?

**Module 2**

1. Power and interconnect delay analysis of CMOS inverter?
2. Implement XOR function using pass transistor logic?
3. Derive  $V_{IL}$ ,  $V_{IH}$ ,  $V_{OH}$ , and  $V_{OL}$  of depletion load inverter?
4. Design 8:1 MUX using transmission gate logic?
5. What are the advantages of NMOS over CMOS ?

**Module 3**

1. Explain the working of sense amplifiers in memory structures?
2. Design a voltage comparator in precharge-evaluate logic .
3. Discuss the cascading problem of P-E logic
4. Discuss the architecture of FLASH EPROM
5. Explain the working of FGMOS

**Module 4**

1. With diagram illustrate the principle of operation of an array multiplier. Show the critical path. Estimate the delay of the multiplier
2. Implement a 3x3 array multiplier?

**Module 5**

1. What is photolithography? With diagram illustrate the steps involved in photolithography process?
2. What is Deal Grove model of oxidation? What are linear and parabolic rate coefficients with reference to oxidation process?
3. Illustrate with diagram the principle of crystal growth by Czochralski method
4. Explain DEAL-GROVE model of oxidation?
5. What are the requirements of a "clean-room" in VLSI fabrication

ECT306	INFORMATION THEORY AND CODING	CATEGORY	L	T	P	CREDIT
		PCC	3	1	0	4

**Preamble:** This course aims to lay down the foundation of information theory introducing both source coding and channel coding. It also aims to expose students to algebraic and probabilistic error-control codes that are used for reliable transmission.

**Prerequisite:** MAT 201 Linear Algebra and Calculus, MAT 204 Probability, Random Process and Numerical Methods, ECT 204 Signals and Systems.

**Course Outcomes:** After the completion of the course the student will be able to

CO 1	Explain measures of information – entropy, conditional entropy, mutual information
CO 2	Apply Shannon’s source coding theorem for data compression.
CO 3	Apply the concept of channel capacity for characterize limits of error-free transmission.
CO 4	Apply linear block codes for error detection and correction
CO 5	Apply algebraic codes with reduced structural complexity for error correction
CO 6	Understand encoding and decoding of convolutional and LDPC codes

#### Mapping of course outcomes with program outcomes

	PO 1	PO 2	PO 3	PO 4	PO 5	PO 6	PO 7	PO 8	PO 9	PO 10	PO 11	PO 12
CO 1	3	3										
CO 2	3	3	2	3	3							
CO 3	3	3	2	3	3	2						2
CO 4	3	3	2	3	3	2						2
CO 5	3	3	2	3	3	2						2
CO 6	3	3	2	3	3	2						2

#### Assessment Pattern

Bloom’s Category	Continuous Assessment Tests		End Semester Examination
	1	2	
	Remember	10	
Understand	30	30	60
Apply	10	10	20
Analyse			
Evaluate			
Create			

#### Mark distribution

Total Marks	CIE	ESE	ESE Duration
150	50	100	3 hours

**Continuous Internal Evaluation Pattern:**

Attendance	: 10 marks
Continuous Assessment Test (2 numbers)	: 25 marks
Assignment/Quiz/Course project	: 15 marks

**End Semester Examination Pattern:** There will be two parts; Part A and Part B. Part A contain 10 questions with 2 questions from each module, having 3 marks for each question. Students should answer all questions. Part B contains 2 questions from each module of which student should answer any one. Each question can have maximum 2 sub-divisions and carry 14 marks.

**Course Level Assessment Questions****Course Outcome 1 (CO1): Entropy, Mutual Information**

1. Prove that entropy of a discrete random variable is upper bounded by logarithm of alphabet size.
2. Prove that  $I(X:Y|Z)$  is always greater than or equal to 0.

**Course Outcome 2 (CO2): Source Coding**

1. State and prove Kraft's inequality for uniquely decodable codes.
2. Describe operational meaning of entropy in the light of Shannons's source coding theorem.

**Course Outcome 3 (CO2): Channel Capacity**

1. Derive the expression for capacity of binary symmetric channel.
2. Define differential entropy and derive its expression for a Gaussian distributed random variable with zero mean value and variance  $\sigma^2$ .
3. Explain the inferences from Shannon Hartley theorem with the help of spectral efficiency versus SNR per bit graph.

**Course Outcome 4 (CO4): Linear Block Codes**

1. Construct a table for GF(23) based on the primitive polynomial,  $p(x) = 1 + x + x^3$ .
2. Find generator and parity check matrix in systematic format of the (6,3) linear block code for the given parity matrix.

$$P = \begin{bmatrix} 1 & 1 & 0 \\ 0 & 1 & 1 \\ 1 & 1 & 1 \\ 1 & 0 & 1 \end{bmatrix}$$

3. Explain standard array decoding of linear block codes.

**Course Outcome 4 (CO4): Algebraic codes**

1. Draw and explain the decoder circuit of (n, k) cyclic codes.
2. Give the properties of BCH codes.

**Course Outcome 5 (CO5): Convolutional and LDPC Codes**

1. Obtain the output codeword corresponding to the information sequence (1 1 0 1 1) for a convolutional encoder with rate  $\frac{1}{2}$  and constraint length 4, for generator sequences,  $g(1) = (1011)$  and  $g(2) = (1111)$ .
2. Explain the message-passing decoding algorithm for LDPC codes with respect to binary erasure channel.

**SYLLABUS****Module 1 – Entropy, Sources and Source Coding**

Entropy, Properties of Entropy, Joint and Conditional Entropy, Mutual Information, Properties of Mutual Information.

Discrete memoryless sources, Source code, Average length of source code, Bounds on average length, Uniquely decodable and prefix-free source codes. Kraft Inequality (with proof), Huffman code. Shannon's source coding theorem (both achievability and converse) and operational meaning of entropy.

**Module 2 – Channels and Channel Coding**

Discrete memoryless channels. Capacity of discrete memoryless channels. Binary symmetric channels (BSC), Binary Erasure channels (BEC). Capacity of BSC and BEC. Channel code. Rate of channel code. Shannon's channel coding theorem (both achievability and converse without proof) and operational meaning of channel capacity.

Modeling of Additive White Gaussian channels. Continuous-input channels with average power constraint. Differential entropy. Differential Entropy of Gaussian random variable. Relation between differential entropy and entropy. Shannon-Hartley theorem (with proof – mathematical subtleties regarding power constraint may be overlooked).

Inferences from Shannon Hartley theorem – spectral efficiency versus SNR per bit, power-limited and bandwidth-limited regions, Shannon limit, Ultimate Shannon limit.

**Module 3 – Introduction to Linear Block Codes**

Overview of Groups, Rings, Finite Fields, Construction of Finite Fields from Polynomial rings, Vector spaces.

Block codes and parameters. Error detecting and correcting capability. Linear block codes. Two simple examples -- Repetition code and single parity-check code. Generator and parity-check matrix. Systematic form.

Maximum likelihood decoding of linear block codes. Bounded distance decoding. Syndrome. Standard array decoding.

**Module 4 – A Few Important Classes of Algebraic codes**

Cyclic codes. Polynomial and matrix description. Interrelation between polynomial and matrix view point. Systematic encoding. Decoding of cyclic codes.

(Only description, no decoding algorithms) Hamming Codes, BCH codes, Reed-Solomon Codes.

**Module 5 – Convolutional and LDPC Codes**

Convolutional Codes. State diagram. Trellis diagram. Maximum likelihood decoding. Viterbi algorithm.

Low-density parity check (LDPC) codes. Tanner graph representation. Message-passing decoding for transmission over binary erasure channel.

**Text Books and References**

1. “Elements of Information Theory”, Joy A Thomas, Thomas M Cover, Wiley-Interscience.
2. “Information Theory, Inference and Learning Algorithms”, David JC McKay, Cambridge University Press
3. “Principles of digital communication”, RG Gallager, Cambridge University Press
4. “Digital Communication Systems”, Simon Haykin, Wiley.
5. “Introduction to Coding Theory”, Ron M Roth, Cambridge University Press
6. Shu Lin & Daniel J. Costello, Jr., Error Control Coding : Fundamentals and Applications, 2nd Edition.
7. Modern Coding Theory, Rüdiger Urbanke and TJ Richardson, Cambridge University Press.

**Course Contents and Lecture Schedule**

No	Topic	No. of Lectures
<b>1</b>	<b>Entropy, Sources and Source Coding</b>	
1.1	Entropy, Properties of Entropy, Joint and Conditional Entropy	2
1.2	Mutual Information, Properties of Mutual Information	2
1.3	Discrete memoryless sources, Source code, Average length of source code, Bounds on average length	2
1.4	Uniquely decodable and prefix-free source codes. Kraft Inequality (with proof)	2
1.5	Huffman code. Shannon’s source coding theorem and operational meaning of entropy	2
<b>2</b>	<b>Channels and Channel Coding</b>	
2.1	Discrete memoryless channels. Capacity of discrete memoryless channels	1
2.2	Binary symmetric channels (BSC), Binary Erasure channels (BEC). Capacity of BSC and BEC.	2

2.3	Channel code. Rate of channel code. Shannon's channel coding theorem (without proof) and operational meaning of channel capacity.	2
2.4	Modeling of Additive White Gaussian channels. Continuous-input channels with average power constraint.	1
2.5	Differential entropy. Differential Entropy of Gaussian random variable. Relation between differential entropy and entropy	2
2.6	Shannon-Hartley theorem and its proof	1
2.7	Inferences from Shannon Hartley theorem – spectral efficiency versus SNR, power-limited and bandwidth-limited regions, Shannon limit, Ultimate Shannon limit.	2
<b>3</b>	<b>Introduction to Linear Block Codes</b>	
3.1	Overview of Groups, Rings, Finite Fields, Construction of Finite Fields from Polynomial rings, Vector spaces.	5
3.2	Block codes and parameters. Error detecting and correcting capability	1
3.3	Linear block codes. Generator and parity-check matrix. Systematic form. Two simple examples -- Repetition code and single parity-check code. General examples.	2
3.5	Maximum likelihood decoding of linear block codes. Bounded distance decoding. Syndrome. Standard array decoding.	3
<b>4</b>	<b>A Few Important Classes of Algebraic codes</b>	
4.1	Cyclic codes. Polynomial and matrix description. Interrelation between polynomial and matrix view point. Systematic encoding. Decoding of cyclic codes.	4
4.2	Hamming Codes,	1
4.3	BCH codes, Reed-Solomon Codes.	2
<b>5</b>	<b>Convolutional and LDPC Codes</b>	
5.1	Convolutional Codes.	1
5.2	State diagram. Trellis diagram.	2
5.3	Maximum likelihood decoding. Viterbi algorithm	
5.4	Low-density parity check (LDPC) codes. Tanner graph representation Message-passing decoding for transmission over binary erasure channel.	2



## ECT 306 Information Theory and Coding

### Simulation Assignments

The following simulation assignments can be done with Python/MATLAB/SCILAB/LabVIEW

1. **Source Coding - Huffman Code**
  1. Generate Huffman code for the source with symbol probabilities  $\{1/2, 1/3, 1/6\}$ .
  2. Find the entropy, average codeword length and efficiency of the code.
  3. Create the second order extended source by taking probabilities of 9 symbols in the extended source as the product of every possible combinations of two symbols from the original source.
  4. Generate Huffman code for the extended source symbols and find the entropy, average codeword length and efficiency of the code.
  5. Compare the two efficiencies and appreciate the Shannon's source coding theorem.
  
2. **Binary Symmetric Channel**
  1. Create a  $2 \times 2$  matrix,  $P(Y/X)$  for binary symmetric channel with channel transition probability,  $p < 0.5$ .
  2. Let the input symbol probabilities corresponding to symbol 0 and 1 be  $\alpha$  and  $(1 - \alpha)$  respectively. For different values of  $\alpha$  ranging from 0 to 1, find the joint probability matrix,  $P(X,Y)$  and output probability,  $P(Y)$
  3. Find mutual information,  $I(X; Y) = H(Y) - H(Y/X)$  for each value of  $\alpha$ . Plot the  $I(X; Y)$  versus  $\alpha$  graph and observe the channel capacity.
  
3. **Linear Block Code (LBC)**
  1. Create the  $k \times n$  generator matrix,  $G$  of  $(n, k)$  LBC.
  2. Generate all possible codewords by multiplying the message vector of length,  $k$  with  $G$ .
  3. Calculate the Hamming weight of all codewords and obtain the minimum distance,  $d_{min}$  of the code.
  4. Find its error correcting and detecting capability.
  
5. **Cyclic Code – Encoder & Decoder**
  1. Realize the encoder circuit for  $(7, 4)$  cyclic code in Fig. 4.2 in page 96 in *Error Control Coding: Fundamentals and Applications* by Shu Lin & Daniel J. Costello. Jr.

2. Create a random binary vector of length 4 as input message vector and generate the codeword.
  3. Create binary vector of length 7 with Hamming weight 1 as error vector and add it to the encoder output to generate the receiver output.
  4. Realize the decoder circuit for (7, 4) cyclic code in Fig. 4.9 in page 107 in *Error Control Coding: Fundamentals and Applications* by Shu Lin & Daniel J. Costello. Jr.
  5. Observe the encoder and decoder outputs for different message vectors and error vectors and find the error correcting capability of the code.
6. **Convolutional Code**
1. Implement (2,1,3) convolutional encoder in Fig. 10.1 in page 288 in *Error Control Coding: Fundamentals and Applications* by Shu Lin & Daniel J. Costello. Jr.
  2. Give a message vector,  $u$  of arbitrary length as input to the encoder.
  3. Generate the output code sequence.

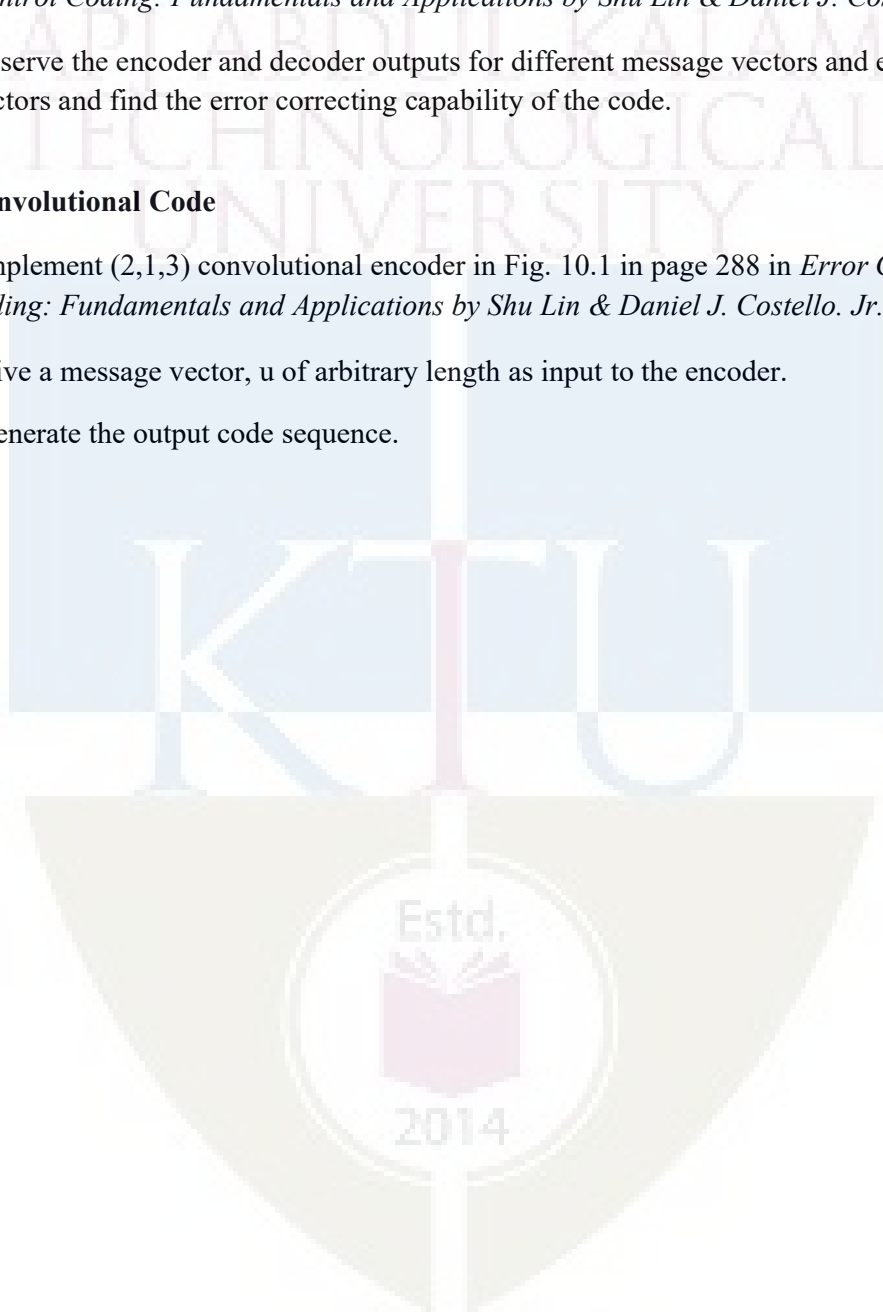

**APJ ABDUL KALAM TECHNOLOGICAL UNIVERSITY**  
**ECT 306 INFORMATION THEORY AND CODING**

Time: 3 hours

Max. Marks:100

**PART A**

Answer **all** questions. Each question carries **3 marks**.

1. A source emits one of four symbols,  $s_0, s_1, s_2, s_3$  with probabilities  $1/3, 1/6, 1/4$  and  $1/4$  respectively. The successive symbols emitted by the source are statistically independent. Calculate the entropy of the source.
2. Identify the instantaneous codes from the code sets listed below.

Symbol	Code I	Code II	Code III	Code IV
$s_0$	0	0	0	00
$s_1$	10	01	01	01
$s_2$	110	001	011	10
$s_3$	1110	0010	110	110
$s_4$	1111	0011	111	111

3. State Shannon's channel coding theorem. What is its significance in digital communication system?
4. An analog signal band limited to 'B' Hz is sampled at Nyquist rate. The samples are quantized into 4 levels. The quantization levels are assumed to be independent and occur with probabilities:  $p_1 = p_4 = 1/8, p_2 = p_3 = 3/8$ . Find the information rate of the source assuming  $B = 100\text{Hz}$ .
5. List the properties of group. Give an example.
6. Show that  $C = \{0000, 1100, 0011, 1111\}$  is a linear code. What is its minimum distance?
7. Explain generation of systematic cyclic code using polynomial description.
8. List the features of Reed Solomon code.
9. Draw a (3,2,1) convolutional encoder with generator sequences,  $g_1^{(1)} = (11), g_1^{(2)} = (01), g_1^{(3)} = (11)$  and  $g_2^{(1)} = (01), g_2^{(2)} = (10), g_2^{(3)} = (10)$ .
10. Draw the Tanner graph of rate  $1/3$  LDPC code for the given parity check matrix.

$$H = \begin{bmatrix} 1 & 1 & 1 & 0 & 0 & 0 \\ 1 & 0 & 0 & 1 & 1 & 0 \\ 0 & 1 & 0 & 1 & 0 & 1 \\ 0 & 0 & 1 & 0 & 1 & 1 \end{bmatrix}$$

**PART B**

Answer **any one** question from each module. Each question carries 14 marks.

**MODULE I**

11 (a) The joint probability of a pair of random variables is given below. Determine  $H(X, Y)$ ,  $H(X/Y)$ ,  $H(Y/X)$  and  $I(X, Y)$ . Verify the relationship between joint, conditional and marginal entropies.

$$P(X, Y) = \begin{bmatrix} 1/3 & 1/3 \\ 0 & 1/3 \end{bmatrix}$$

(10 marks)

11 (b) Explain uniquely decodable and prefix-free property of source code. (4 marks)

12 (a) Find the binary Huffman code for the source with probabilities  $\{1/3, 1/5, 1/5, 2/15, 2/15\}$ . Also find the efficiency of the code. (9 marks)

12 (b) Prove that  $H(Y) \geq H(Y/X)$ . (5 marks)

**MODULE II**

13 (a) A voice grade channel of the telephone network has a bandwidth of 3.4 KHz. Calculate channel capacity of the telephone channel for signal to noise ratio of 30 dB. Also determine the minimum SNR required to support information transmission through the telephone channel at the rate of 4800 bits/sec.

(7 marks)

13 (b) Derive the expression for channel capacity for binary erasure channel. (7 marks)

14 (a) A binary channel has the following noise characteristic.

$$P(Y/X) = \begin{bmatrix} 2/3 & 1/3 \\ 1/3 & 2/3 \end{bmatrix}$$

If the input symbols are transmitted with probabilities  $3/4$  and  $1/4$  respectively, find  $I(X; Y)$ . Also compute channel capacity and what are the input symbol probabilities that correspond to the channel capacity. (9 marks)

14 (b) State Shannon Hartley theorem and explain the significance of Shannon limit. (6 marks)

**MODULE III**

15 (a) The parity check matrix of (7,4) linear block code is given as

$$H = \begin{bmatrix} 1 & 00 & 1 & 01 & 1 \\ 0 & 10 & 1 & 11 & 0 \\ 0 & 01 & 0 & 11 & 1 \end{bmatrix}$$

Compute the minimum distance of the code and find its error detection and correcting capability. Suppose that the received codeword,  $r = (1001111)$ . Determine whether the received codeword is in error? If so, form the decoding table and obtain the correct codeword. (9 marks)

16 (b) List the properties of vector space. Define subspace. (5 marks)

17 (a) The parity bits of a (8, 4) linear systematic block code are generated by

$$c_5 = d_1 + d_2 + d_4$$

$$c_6 = d_1 + d_2 + d_3$$

$$c_7 = d_1 + d_3 + d_4$$

$$c_8 = d_2 + d_3 + d_4$$

(+ sign denotes modulo-2 addition)

where  $d_1, d_2, d_3$  and  $d_4$  are message bits and  $c_5, c_6, c_7$  and  $c_8$  are parity bits. Find generator matrix  $G$  and parity check matrix  $H$  for this code. Draw the encoder circuit (7 marks)

17 (b) Explain the construction of finite field from polynomial ring with the help of an ex-ample.

(7 marks)

#### MODULE IV

18 (a) Consider a (7, 4) cyclic code with generator polynomial,  $g(x) = 1 + x + x^3$ . Express the generator matrix and parity-check matrix in systematic and non-systematic form

(8 Marks)

18 (b) Find the generator polynomial for single, double and triple error correcting BCH code of block length,  $n = 15$ .

(6 marks)

19 (a) Draw syndrome circuit for a (7,4) cyclic code generated by  $g(x)=1+x+x^3$ . If the received vector  $r$  is [0010110] what is the syndrome of  $r$ ? Explain the circuit with a table showing the contents of the syndrome register.

(8 Marks)

19 (b) What are the features of Hamming code? Find the parity check matrix for (15, 11) Hamming code.

(6 marks)

#### MODULE V

20 (a) Draw the state diagram of a convolution encoder with rate  $1/3$  and constraint length

3 for generator sequences  $g^{(1)} = (1\ 0\ 0)$ ,  $g^{(2)} = (1\ 0\ 1)$ ,  $g^{(3)} = (1\ 1\ 1)$ .

(7 marks)

20 (b) Explain message passing decoding algorithm for LDPC codes with the help of an example.

(7 marks)

21 For a (2,1,2) convolutional encoder with generator sequences  $g^{(1)} = (1\ 1\ 1)$  and  $g^{(2)} = (1\ 0\ 1)$ . Draw Trellis and perform Viterbi decoding on this trellis for the received sequence {01, 10, 10, 11, 01, 01, 11} and obtain the estimate of the transmitted sequence.

(14 marks)

APJ ABDUL KALAM  
TECHNOLOGICAL  
UNIVERSITY

---

# **SEMESTER VI**

---

## **PROGRAM ELECTIVE I**

---



ECT312	DIGITAL SYSTEM DESIGN	CATEGORY	L	T	P	CREDIT
		PEC	2	1	0	3

**Preamble:** This course aims to design hazard free synchronous and asynchronous sequential circuits and implement the same in the appropriate hardware device

**Prerequisite:** ECT203 Logic Circuit Design

**Course Outcomes:** After the completion of the course the student will be able to

CO 1 K4	Analyze clocked synchronous sequential circuits
CO 2 K4	Analyze asynchronous sequential circuits
CO 3 K3	Design hazard free circuits
CO 4 K3	Diagnose faults in digital circuits
CO 5 K2	Summarize the architecture of FPGA and CPLDs

#### Mapping of course outcomes with program outcomes

	PO 1	PO 2	PO 3	PO 4	PO 5	PO 6	PO 7	PO 8	PO 9	PO 10	PO 11	PO 12
CO1	3	3	3		2				2	2		3
CO2	3	3			2				2	2		3
CO3	3	3	3	3					2	2		3
CO4	3	2		1					2	2		3
CO5	2								2	2		3

#### Assessment Pattern

Bloom's Category		Continuous Tests	Assessment	End Semester Examination
		1	2	
Remember	K1	10	10	15
Understand	K2	10	20	30
Apply	K3	20	20	35
Analyse	K4	10		20
Evaluate				
Create				

**Mark distribution**

Total Marks	CIE	ESE	ESE Duration
150	50	100	3 hours

**Continuous Internal Evaluation Pattern:**

Attendance	: 10 marks
Continuous Assessment Test (2 numbers)	: 25 marks
Assignment/Quiz/Course project	: 15 marks

**End Semester Examination Pattern:** There will be two parts; Part A and Part B. Part A contain 10 questions with 2 questions from each module, having 3 marks for each question. Students should answer all questions. Part B contains 2 questions from each module of which student should answer any one. Each question can have maximum 2 sub-divisions and carry 14 marks.

**Course Level Assessment Questions****Course Outcome 1 (CO1): Analyze clocked synchronous sequential circuits (K4)**

- Construct an ASM chart for a sequence recognizer to recognize the input sequence of pairs  $x_1x_2 = 01, 01, 11, 00$ . The output variable, 'z' is asserted when  $x_1x_2 = 00$  if and only if the three preceding pairs of inputs are  $x_1x_2 = 01, 01$  and  $11$ , in that order.
- Obtain a minimal state table for a clocked synchronous sequential network having a single input line 'x' in which the symbols 0 and 1 are applied and a single output line 'z'. An output of 1 is to be produced if and only if the 3 input symbols following two consecutive input 0's consist of at least one 1. An example of input/output sequences that satisfy the conditions of the network specifications is:
 
$$x=0100010010010010000000011$$

$$z=0000001000000100000000001$$
- Analyse the following clocked synchronous sequential network. Derive the next state and output equations. Obtain the excitation table, transition table, state table and state diagram.

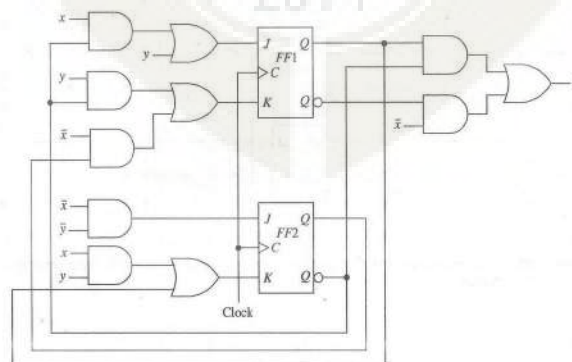



**Course Outcome 2 (CO2): Analyze asynchronous sequential circuits (K4)**

1. A reduced flow table for a fundamental-mode asynchronous sequential network is given below. Using the universal multiple-row state assignment, construct the corresponding expanded flow table and transition table. Assign outputs where necessary such that there is at most a single output change during the time the network is unstable. Assume that the inputs  $x_1$  and  $x_2$  never change simultaneously.

Present state	Next state				Output (z)			
	Input state ( $x_1x_2$ )				Input state ( $x_1x_2$ )			
	00	01	10	11	00	01	10	11
A	(A)	B	(A)	D	1	-	0	-
B	D	(B)	(B)	C	-	0	1	-
C	A	(C)	(C)	(C)	-	1	1	0
D	(D)	C	A	(D)	0	-	-	1

2. Analyze the asynchronous sequential network by forming the excitation/transition table, state table, flow table and flow diagram. The network operates in the fundamental mode with the restriction that only one input variable can change at a time.

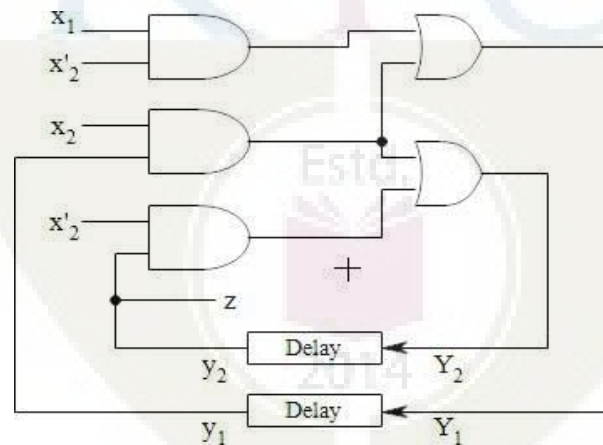

3. Describe races in ASN with example.

**Course Outcome 3 (CO3): Design hazard free circuits (K3)**

1. Differentiate between static and dynamic hazard.
2. Examine the possibility of hazards in the (i) OR-AND logic circuit whose Boolean function is given by  $f = \sum(0,2,6,7)$  (ii) AND-OR logic circuit whose Boolean function is given by  $f = \sum(3,4,5,7)$ . Show how the hazard can be detected and eliminated in each circuit.

- Investigate the problem of clock skew in practical sequential circuits and suggest solutions with justification to minimize or eliminate it.

**Course Outcome 4 (CO4): Diagnose faults in digital circuits (K3)**

- Illustrate the fault table method used for effective test set generation for the circuit whose Boolean function is  $z = \bar{x}_1x_2 + x_3$
- Find the test vectors of all SA0 and SA1 faults of the circuit whose Boolean function is  $f = \bar{x}_1x_2 + x_1x_2x_3$  by the Kohavi algorithm.
- Write a note on BIST techniques.

**Course Outcome 5 (CO5): Summarize the architecture of FPGA and CPLDs (K2)**

- Draw and explain the architecture of Xilinx XC4000 configurable logic block.
- Draw and explain the architecture of Xilinx 9500 CPLD family.
- Explain the internal structure of XC4000 input/output block.

## SYLLABUS

### Module 1: Clocked Synchronous Networks

Analysis of clocked Synchronous Sequential Networks (CSSN), Modelling of CSSN – State assignment and reduction, Design of CSSN, ASM Chart and its realization

### Module 2: Asynchronous Sequential Circuits

Analysis of Asynchronous Sequential Circuits (ASC), Flow table reduction- Races in ASC, State assignment problem and the transition table- Design of AS, Design of ALU

### Module 3: Hazards

Hazards – static and dynamic hazards – essential, Design of Hazard free circuits – Data synchronizers, Mixed operating mode asynchronous circuits, Practical issues- clock skew and jitter, Synchronous and asynchronous inputs – switch bouncing

### Module 4: Faults

Fault table method – path sensitization method – Boolean difference method, Kohavi algorithm, Automatic test pattern generation – Built in Self Test (BIST)

### Module 5: CPLDs and FPGA

CPLDs and FPGAs - Xilinx XC 9500 CPLD family, functional block diagram– input output block architecture - switch matrix, FPGAs – Xilinx XC 4000 FPGA family – configurable logic block - input output block, Programmable interconnect

**Text Books**

1. Donald G Givone, Digital Principles & Design, Tata McGraw Hill, 2003
2. John F Wakerly, Digital Design, Pearson Education, Delhi 2002
3. John M Yarbrough, Digital Logic Applications and Design, Thomson Learning

**Reference Books**

1. Miron Abramovici, Melvin A. Breuer and Arthur D. Friedman, Digital Systems Testing and Testable Design, John Wiley & Sons Inc.
2. Morris Mano, M.D.Ciletti, Digital Design, 5th Edition, PHI.
3. N. N. Biswas, Logic Design Theory, PHI
4. Richard E. Haskell, Darrin M. Hanna , Introduction to Digital Design Using Digilent FPGA Boards, LBE Books- LLC
5. Samuel C. Lee, Digital Circuits and Logic Design, PHI
6. Z. Kohavi, Switching and Finite Automata Theory, 2nd ed., 2001, TMH

**Course Contents and Lecture Schedule**

No	Topic	No. of Lectures
<b>1</b>	<b>Clocked Synchronous Networks</b>	
1.1	Analysis of clocked Synchronous Sequential Networks(CSSN)	2
1.2	Modelling of CSSN – State assignment and reduction	2
1.3	Design of CSSN	2
1.4	ASM Chart and its realization	1
<b>2</b>	<b>Asynchronous Sequential Circuits</b>	
2.1	Analysis of Asynchronous Sequential Circuits (ASC)	2
2.2	Flow table reduction- Races in ASC	2
2.3	State assignment problem and the transition table- Design of AS	2
2.4	Design of ALU	2
<b>3</b>	<b>Hazards</b>	
3.1	Hazards – static and dynamic hazards – essential	1
3.2	Design of Hazard free circuits – Data synchronizers	1
3.3	Mixed operating mode asynchronous circuits	1
3.4	Practical issues- clock skew and jitter	1
3.5	Synchronous and asynchronous inputs – switch bouncing	2
<b>4</b>	<b>Faults</b>	
4.1	Fault table method – path sensitization method – Boolean difference method	2
4.2	Kohavi algorithm	2
4.3	Automatic test pattern generation – Built in Self Test(BIST)	3
<b>5</b>	<b>CPLDs and FPGA</b>	
5.1	CPLDs and FPGAs - Xilinx XC 9500 CPLD family, functional block diagram– input output block architecture - switch matrix	3
5.2	FPGAs – Xilinx XC 4000 FPGA family – configurable logic block - input output block, Programmable interconnect	3

**Simulation Assignments:**

At least one assignment should be design of digital circuits that can be used in day today life. This has to be done in a phased manner. The first phase involves the design in HDL (VHDL/ Verilog) and the second phase implementing the same in a hardware device. Some of the assignments are as listed below:

1. Design of vending machine
2. Design of ALU
3. Architecture of different FPGAs
4. Architecture of different CPLDs
5. Fault detection methods other than those mentioned in the syllabus
6. Metastability condition and methods to avoid it

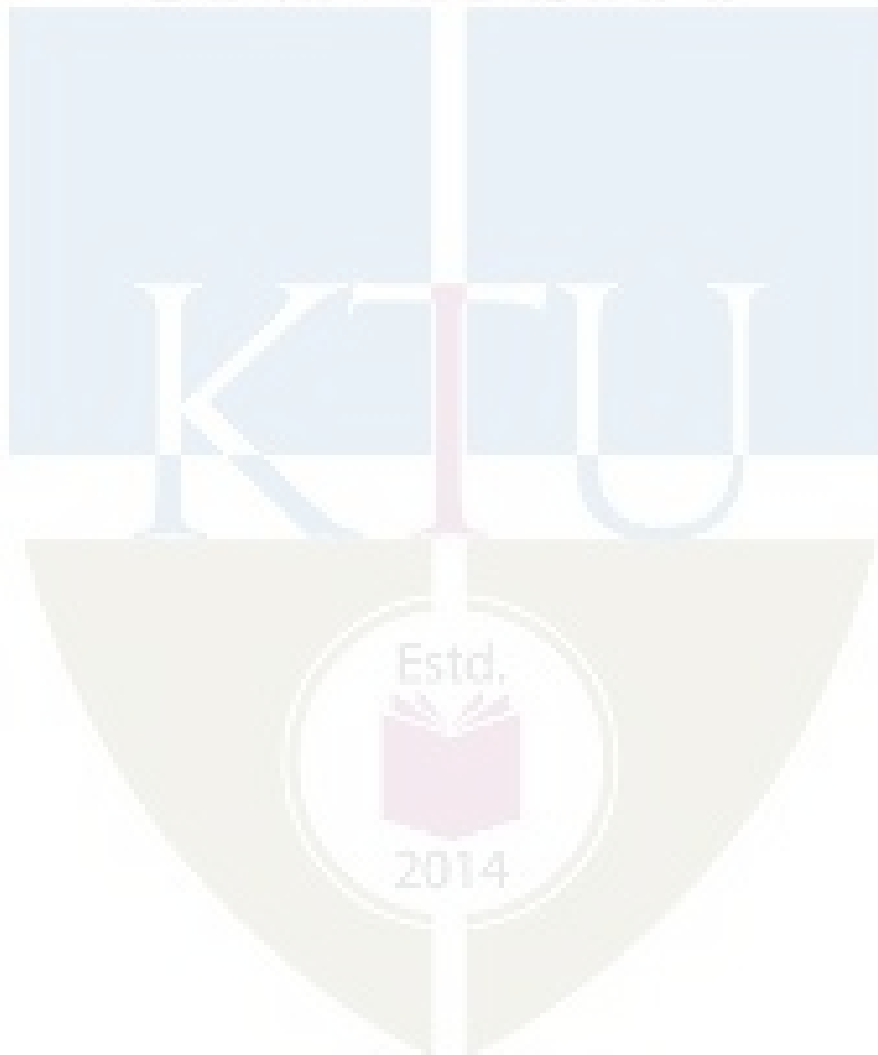

**Model Question paper**

**APJ ABDUL KALAM TECHNOLOGICAL UNIVERSITY**

SIXTH SEMESTER B.TECH DEGREE EXAMINATION, (Model Question Paper)

Course Code: ECT312

Course Name: DIGITAL SYSTEM DESIGN

Max. Marks: 100

Duration: 3 Hours

**PART A**

Answer ALL Questions. Each carries 3 marks.

- |    |   |    |
|----|---|----|
| 1  | Differentiate Mealy and Moore models.                   | K1 |
| 2  | What are the elements in an ASM chart?                  | K1 |
| 3  | Describe one-hot assignment technique.                  | K2 |
| 4  | Define critical and non-critical races.                 | K1 |
| 5  | What is jitter? List the sources of clock jitter.       | K2 |
| 6  | Differentiate positive skew and negative skew.          | K2 |
| 7  | List the different types of faults in digital circuits. | K1 |
| 8  | Differentiate between fault and defect.                 | K2 |
| 9  | What are FPGA? What are the advantages ofFPGA?          | K1 |
| 10 | Differentiate between FPGA and CPLD                     | K2 |

**PART – B**

Answer one question from each module; each question carries 14 marks.

**Module - I**

- 11 a Analyze the following sequential network. Derive the next state and output equations. Obtain its transition table and state table.

8

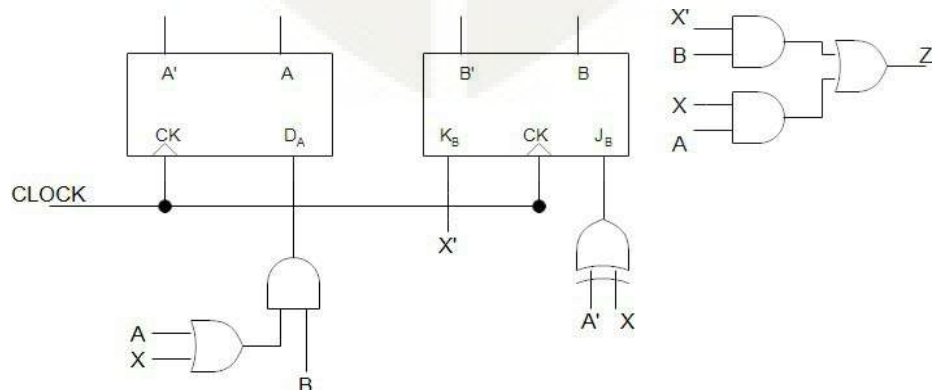

CO1  
K4

- b. Construct an ASM chart for the following state diagram shown. Determine the model of CSSN that this system conforms to with proper justification.

6

CO1  
K3

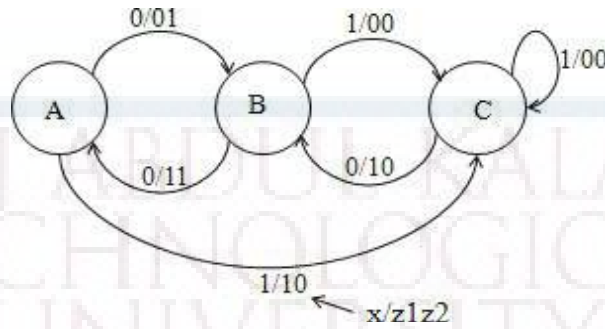

OR

- 12 For the clocked synchronous sequential network, construct the excitation table, transition table, state table and state diagram.

8

CO1  
K4

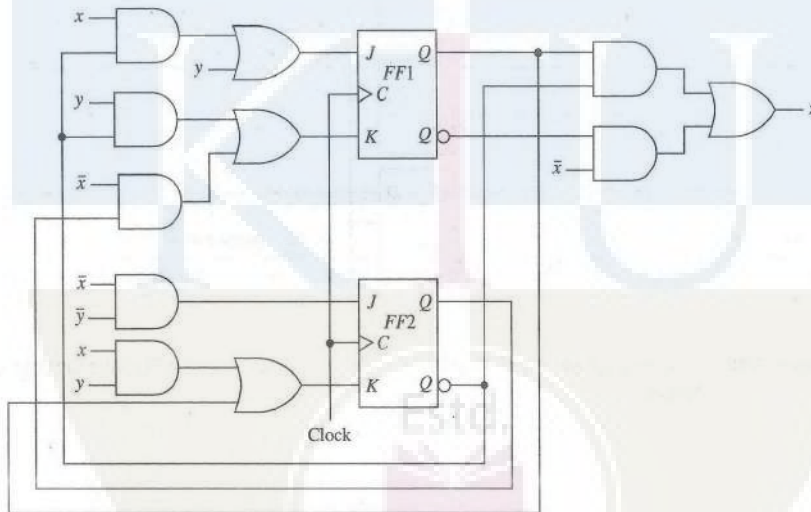

- b. Obtain a minimal state table for a clocked synchronous sequential network having a single input line 'x' in which the symbols 0 and 1 are applied and a single output line 'z'. An output of 1 is to be produced if and only if the 3 input symbols following two consecutive input 0's consist of at least one 1. An example of input/output sequences that satisfy the conditions of the network specifications is:

6

x= 0100010010010010000000011

z= 0000001000000100000000001

CO1  
K3

Module - II

13a Analyze the asynchronous sequential network by forming the excitation/transition table, state table, flow table and flow diagram. The network operates in the fundamental mode with the restriction that only one input variable can change at a time.

14

CO2

K4

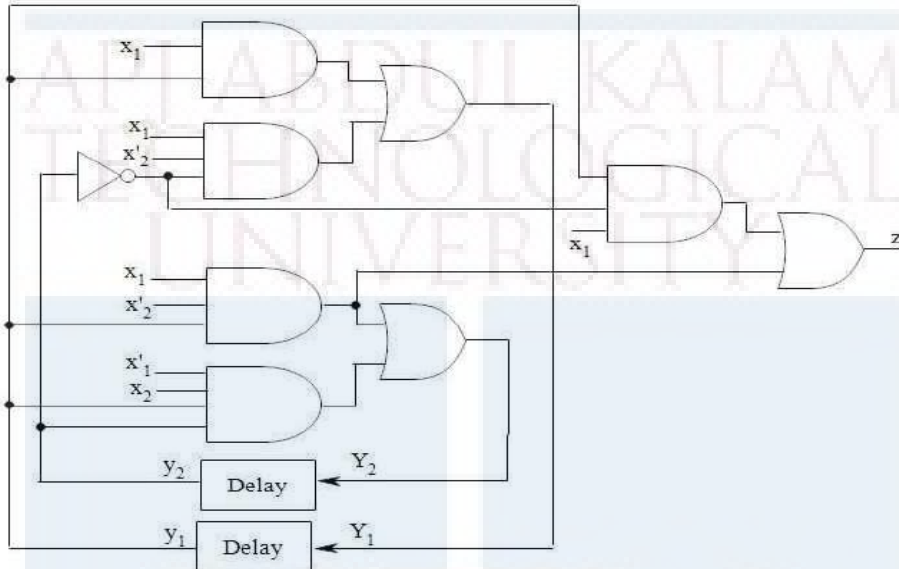

OR

14a A reduced flow table for a fundamental-mode asynchronous sequential network is given below. Using the universal multiple-row state assignment, construct the corresponding expanded flow table and transition table. Assign outputs where necessary such that there is at most a single output change during the time the network is unstable. Assume that the inputs never change simultaneously.

14

CO2

K4

Present state	Next state				Output (z)			
	Input state ( $x_1x_2$ )				Input state ( $x_1x_2$ )			
	00	01	10	11	00	01	10	11
A	(A)	B	(A)	D	1	-	0	-
B	D	(B)	(B)	C	-	0	1	-
C	A	(C)	(C)	(C)	-	1	1	0
D	(D)	C	A	(D)	0	-	-	1

**Module - III**

- 15a. Examine the possibility of hazard in the OR-AND logic circuit whose Boolean function is given by  $f = \sum(0,2,6,7)$ . Show how the hazard can be detected and eliminated. 8  
CO3
- b. Explain essential hazards in asynchronous sequential networks. What are the constraints to be satisfied to avoid essential hazards? K3  
6

**OR**

- 16a Draw the logic diagram of the POS expression  $Y = (x_1 + x_2')(x_2 + x_3)$ . Show that there is a static-0 hazard when  $x_1$  and  $x_3$  are equal to 0 and  $x_2$  goes from 0 to 1. Find a way to remove the hazard by adding one or more gates. 9  
CO3  
K3

- b Discuss the concept of switch bouncing and suggest a suitable solution. 5  
K3

**Module - IV**

- 17a Illustrate the fault table method used for effective test set generation for the circuit whose Boolean function is  $z = \bar{x}_1x_2 + x_3$  8  
CO 4  
K3
- b How can the timing problems in asynchronous sequential circuits be solved using mixed operating mode circuits? 6  
K3

**OR**

- 18 Find the test vectors of all SA0 and SA1 faults of the circuit whose Boolean function is  $f = \bar{x}_1x_2 + x_1x_2x_3$  by the Kohavi algorithm. 8  
CO4  
K3
- b. Identify different test pattern generation for BIST 6

2014

CO4  
K3**Module - V**

- 19 Explain the architecture of XC 4000 FPGA family. 14  
CO5  
K2

**OR**

- 20 Draw and explain the architecture of Xilinx 9500 CPLD family. Also explain the function block architecture. 14  
CO5  
K2



ECT322	POWER ELECTRONICS	CATEGORY	L	T	P	CREDIT
		PEC	2	1	0	3

**Preamble:** This course aims to develop the skill of the design of various power electronic circuits.

**Prerequisite:** ECT201 Solid State Devices, ECT202 Analog Circuits

**Course Outcomes:** After the completion of the course the student will be able to

CO 1 K2	Understand the characteristics of important power semiconductor switches
CO 2 K3	Apply the principle of drive circuits and snubber circuits for power semiconductor switches
CO 3 K3	Build diode bridge rectifiers and Controlled rectifiers
CO 4 K3	Develop DC – DC Switch-Mode Converter
CO 5 K2	Illustrate the principle of DC – AC Switch-Mode Inverter
CO 6 K3	Apply the principle of power electronics for various applications

**Mapping of course outcomes with program outcomes**

	PO 1	PO 2	PO 3	PO 4	PO 5	PO 6	PO 7	PO 8	PO 9	PO 10	PO 11	PO 12
CO 1		2			2							
CO 2		3			2							
CO 3		3			2							
CO 4		3			2							
CO 5		2			2							
CO 6		3			2							

**Assessment Pattern**

Bloom's Category		Continuous Assessment Tests		End Semester Examination
		1	2	
Remember	K1	10	10	10
Understand	K2	30	30	60
Apply	K3	10	10	30
Analyse				
Evaluate				
Create				

**Mark distribution**

Total Marks	CIE	ESE	ESE Duration
150	50	100	3 hours

**Continuous Internal Evaluation Pattern:**

Attendance	: 10 marks
Continuous Assessment Test (2 numbers)	: 25 marks
Assignment/Quiz/Course project	: 15 marks

**End Semester Examination Pattern:** There will be two parts; Part A and Part B. Part A contain 10 questions with 2 questions from each module, having 3 marks for each question. Students should answer all questions. Part B contains 2 questions from each module of which student should answer any one. Each question can have maximum 2 sub-divisions and carry 14 marks.

**Course Level Assessment Questions**

**Course Outcome 1 (CO1): Understand the characteristics of important power semiconductor switches.**

1. Illustrate the static and dynamic characteristics, Power BJT, Power MOSFET and IGBT.
2. Illustrate the construction and characteristics of SCR and GTO
3. Model and simulate power semiconductor switches.

**Course Outcome 2 (CO2): Apply the principle of drive circuits and snubber circuits for power semiconductor switches.**

1. Design the base drive circuits for Power BJT.
2. Design the gate drive circuits for Power MOSFET.
3. Outline the principle of snubber circuits for power switches.
4. Model and simulate above circuits.

**Course Outcome 3 (CO3): Build diode bridge rectifiers and Controlled Rectifiers.**

1. Explain the operation of three phase diode rectifier and the effect of various loads on the rectifier function
2. Explain the operation of controlled rectifiers and the effect of various loads on the rectifier function
3. Model and simulate diode rectifiers and controlled rectifiers for various loads

**Course Outcome 4 (CO4): Develop the principle of DC – DC Switch-Mode Converter**

1. Illustrate the principle of DC-DC converters under steady state conditions.
2. Design non-isolated and isolated DC-DC converters for given specifications.
3. Model and simulate non-isolated and isolated DC-DC Switch-Mode converters

**Course Outcome 5 (CO5): Illustrate the principle of DC – AC Switch-Mode Inverter.**

1. Understand the different types of inverters
2. Construct Driven Inverters for given specifications.
3. Model and simulate Driven Inverters

**Course Outcome 6 (CO6): Apply the principle of power electronics for various applications.**

1. Illustrate the principle of Adjustable-speed DC drive.
2. Explain the principle of Variable frequency PWM-VSI Induction Motor drives
3. Give at least two applications of power electronic circuits for residential applications.
4. Explain at least two applications of power electronic circuits for industrial applications

**SYLLABUS****Module 1 : Power Semiconductor Switches**

Power diodes, Power BJT, Power MOSFET and IGBT - static and dynamic characteristics, SCR and GTO

**Module 2 : Protection circuits and Rectifiers**

BJT and MOSFET drive circuits, Snubber circuits, Three phase diode bridge rectifiers, Single phase and three phase controlled rectifiers.

**Module 3 : DC – DC Switch Mode Converters**

Buck, Boost and Buck-boost DC-DC converters

Waveforms and expression of DC-DC converters for output voltage, voltage and current ripple under continuous conduction mode. (No derivation required)

Isolated converters: Flyback, Forward, Push Pull, Half bridge and Full bridge converters –

Waveforms and governing equations (No derivation required)

**Module 4 : DC-AC Switch Mode Inverters**

Inverter topologies, Driven Inverters : Push-Pull, Half bridge and Full bridge configurations,  
Three phase inverter, Pulse width modulation

**Module 5 : Applications**

DC Motor Drives, Induction Motor Drives, Residential and Industrial applications.

**Text Books**

1. Umanand L, “Power Electronics: Essentials & Applications”, Wiley India, 2015
2. Ned Mohan, Tore M Undeland, William P Robbins., “Power Electronics: Converters, Applications, and Design”., Wiley India Pvt. Ltd, 3/e, 2015

**Reference Books**

1. Muhammad H. Rashid., “Power Electronics : Circuits, Devices, and Applications”, Pearson Education India, 4/e, 2014.
2. Daniel W. Hart, Power Electronics, McGraw Hill, 2011.

**Course Contents and Lecture Schedule**

No	Topic	No. of Lectures
<b>1</b>	<b>Power Semiconductor Switches</b>	
1.1	Power diodes and Bipolar power transistors – structure, static and dynamic characteristics	2
1.2	Power MOSFET and IGBT – structure, static and dynamic characteristics	3
1.3	SCR and GTO – construction and characteristics	2
<b>2</b>	<b>Protection circuits and Rectifiers</b>	
2.1	BJT and MOSFET driver circuits (at least two circuits each)	2
2.2	Snubber circuits – ON and OFF snubbers	1
2.3	Three phase diode bridge rectifiers – basic principles only	1
2.4	Single phase and three phase Controlled rectifiers (with R, RL & RLE loads) – basic principles only	3
<b>3</b>	<b>DC – DC Switch Mode Converters</b>	
3.1	Buck, Boost and Buck-Boost DC-DC converters	2
3.2	Waveforms and expression of DC-DC converters for output voltage, voltage and current ripple under continuous conduction mode (No derivation required)	3
3.3	Isolated converters: Flyback, Forward, Push Pull, Half bridge and Full bridge converters – Waveforms and governing equations (No derivation required)	3
<b>4</b>	<b>DC-AC Switch Mode Inverters</b>	
4.1	Inverter topologies	2
4.2	Driven Inverters: Push-Pull, Half bridge and Full bridge	2

	configurations	
4.3	Three phase inverter	1
4.4	Sinusoidal and Space vector modulation PWM in three phase inverters	2
<b>5</b>	<b>Applications</b>	
5.1	DC Motor Drives – Adjustable-speed DC drive	2
5.2	Induction Motor Drives – Variable frequency PWM-VSI drives	2
5.3	Residential and Industrial applications	2

**Assignment:**

At least one assignment should be simulation of power electronic circuits using any circuit simulation software.

**Simulation Assignments (ECT 322)**

The following simulations can be done in LTspice or any other circuit simulation software.

1. Model and simulate BJT test circuit Fig. 1.50 of Umanand L., Power Electronics Essentials and Applications, Wiley India, 2015, page no.48.
2. Model and simulate MOSFET test circuit Fig. 1.51 of Umanand L., Power Electronics Essentials and Applications, Wiley India, 2015, page no.49.
3. Model and simulate IGBT test circuit Fig. 1.52 of Umanand L., Power Electronics Essentials and Applications, Wiley India, 2015, page no.50.
4. Model and simulate BJT drive test circuit Fig. 2.33 of Umanand L., Power Electronics Essentials and Applications, Wiley India, 2015, page no.86.
5. Model and simulate MOSFET drive test circuit Fig. 2.36 of Umanand L., Power Electronics Essentials and Applications, Wiley India, 2015, page no.88.
6. Model and simulate MOSFET shunt snubber test circuit Fig. 2.37 of Umanand L., Power Electronics Essentials and Applications, Wiley India, 2015, page no.89.
7. Model and simulate MOSFET series snubber test circuit Fig. 2.39 of Umanand L., Power Electronics Essentials and Applications, Wiley India, 2015, page no.90.
8. Model and simulate diode rectifiers and controlled rectifiers for various loads.
9. Model and simulate Buck converter circuit Fig. 5.68 of Umanand L., Power Electronics Essentials and Applications, Wiley India, 2015, page no.277.
10. Model and simulate Boost converter circuit Fig. 5.70 of Umanand L., Power Electronics Essentials and Applications, Wiley India, 2015, page no.278.
11. Model and simulate Buck-boost converter circuit Fig. 5.71 of Umanand L., Power Electronics Essentials and Applications, Wiley India, 2015, page no.279.

12. Model and simulate Forward converter circuit Fig. 5.72 of Umanand L., Power Electronics Essentials and Applications, Wiley India, 2015, page no.280.
13. Model and simulate Flyback converter circuit Fig. 5.73 of Umanand L., Power Electronics Essentials and Applications, Wiley India, 2015, page no.281.
14. Model and simulate Driven Inverters
15. Model and simulate Pulse Width Modulator

**Model Question paper****APJ ABDUL KALAM TECHNOLOGICAL UNIVERSITY**

SIXTH SEMESTER B.TECH DEGREE EXAMINATION, (Model Question Paper)

**Course Code: ECT 322****Program: Electronics and Communication Engineering****Course Name: Power Electronics**

Max.Marks: 100

Duration: 3Hours

**PART A**

Answer ALL Questions. Each Carries 3 mark.

1	What is meant by reverse recovery time for a diode	K2	CO1
2	What is the tail current in IGBT ?	K2	CO1
3	What is the purpose of snubber circuits ?	K2	CO2
4	Obtain the expression for average load voltage in three phase full wave bridge rectifier	K3	CO3
5	What is volt-second balancing?	K2	CO4
6	What is the flux walking problem in push-pull converter ?	K2	CO4
7	What is the distinction between chopper, oscillators and inverters ?	K3	CO5
8	Distinguish between driven and self-driven inverters.	K2	CO5
9	How converters are used in induction heating ?	K2	CO6
10	What is regenerative braking in PWM-VSI drive?	K2	CO6

**PART – B**

Answer one question from each module; each question carries 14 marks.

<b>Module – I</b>				
11(a)	Compare and contrast power BJT, MOSFET and IGBT for switching applications	7	CO 1	K2
11(b)	A diode and a 10 $\Omega$ resistor are connected in series to a square wave voltage source of 50V peak. The reverse recovery time for the diode is 200nsec. Find the switching loss of the diode when the input frequency is 100 KHz.	7	CO 1	K3
<b>OR</b>				
12(a)	With the two-transistor model of SCR, explain the working principle of SCR	7	CO 1	K2
12(b)	Illustrate the dynamic characteristics of GTO	7	CO 1	K2
<b>Module – II</b>				
13(a)	Illustrate the base current requirement of power BJT	7	CO 2	K2
13(b)	Explain the operation of any one type of the power BJT base drive circuit	7	CO 2	K2
<b>OR</b>				
14(a)	Illustrate the principle of operation of a single-phase, 2 pulse, fully controlled rectifier for RL load with circuit diagram and waveforms.	10	CO 3	K2
14(b)	Deduce the expression for average load voltage in the circuit.	4	CO 3	K2
<b>Module – III</b>				
15(a)	Explain the operation of Buck-Boost converter and illustrate the operation with the inductor current and switching waveforms.	8	CO 4	K2
15(b)	A Buck-Boost converter that switching at 50 KHz is supplied with an input voltage that varies between 5V to 10V. The output is required to be regulated at 15V. A load resistor of 15 $\Omega$ is connected across the output. If the maximum allowable inductor current ripple is 10% of the average inductor current, estimate the value of the inductance to be used in the Buck-Boost converter.	6	CO 4	K3
<b>OR</b>				

16(a)	Describe the principle of operation of the full-bridge converter with circuit diagram and waveforms.	8	CO 4	K2
16(b)	How is the flux walking problem solved in full-bridge converter ?	6	CO 4	K2
<b>Module – IV</b>				
17(a)	Explain the operation of push-pull inverter	8	CO 5	K2
17(b)	Illustrate the PWM switching scheme for sine wave output of the inverter	6	CO 5	K2
<b>OR</b>				
18(a)	Enumerate the principle of operation of three phase inverters	8	CO 5	K2
18(b)	What is Space vector modulation in three phase inverters	6	CO 5	K2
<b>Module – V</b>				
19(a)	Explain the principle of adjustable speed DC drive using switched mode DC-DC converter.	8	CO 6	K2
19(b)	Compare adjustable speed DC drives using switched mode DC-DC converter and line frequency-controlled converter.	6	CO 6	K2
<b>OR</b>				
20 (a)	Illustrate the principle of operation of Variable frequency PWM-VSI Induction Motor drive.	9	CO 6	K2
20(b)	Explain dissipative braking scheme in Induction Motor drive.	5	CO 6	K2



ECT332	DATA ANALYSIS	CATEGORY	L	T	P	CREDIT
		PEC	2	1	0	3

**Preamble:** This course aims to set the foundation for students to develop new-age skills pertaining to analysis of large-scale data using modern tools.

**Prerequisite:** None

**Course Outcomes:** After the completion of the course the student will be able to

CO 1	Read and write data to and fro spreadsheets and databases
CO 2	Work with large data as pandas data frames
CO 3	Perform PCA and cluster analysis on data frames
CO 4	Perform Bayesian analysis on data frames.
CO 5	Apply machine learning in data analysis problems
CO 6	Apply methods in high performance computing for data analysis

#### Mapping of course outcomes with program outcomes

	PO 1	PO 2	PO 3	PO 4	PO 5	PO 6	PO 7	PO 8	PO 9	PO 10	PO 11	PO 12
CO 1	3	3			3							2
CO 2	3	3	2	3	3							
CO 3	3	3	2	3	3	2						2
CO 4	3	3	2	3	3	2						2
CO 5	3	3	2	3	3	2						2
CO 6	3	3	2	3	3	2						2

#### Assessment Pattern

Bloom's Category	Continuous Assessment Tests		End Semester Examination
	1	2	
Remember	10	10	20
Understand	30	30	60
Apply	10	10	20
Analyse			
Evaluate			
Create			

#### Mark distribution

Total Marks	CIE	ESE	ESE Duration
150	50	100	3 hours

**Continuous Internal Evaluation Pattern:**

Attendance	: 10 marks
Continuous Assessment Test (2 numbers)	: 25 marks
Assignment/Quiz/Course project	: 15 marks

**End Semester Examination Pattern:** There will be two parts; Part A and Part B. Part A contain 10 questions with 2 questions from each module, having 3 marks for each question. Students should answer all questions. Part B contains 2 questions from each module of which student should answer any one. Each question can have maximum 2 sub-divisions and carry 14 marks.

**Course Level Assessment Questions****Course Outcome 1 (CO1): Read and write data to and fro spreadsheets and databases**

1. Write Python code to read an .xls file using xlrd module. Svc it as a different .xlsx file using openpyxl.
2. Write Python code to read mongodb data base.

**Course Outcome 2 (CO2): Work with pandas dataframes**

1. Write Python code read a table in a pdf file as a pandas dataframe.
2. Write Python code to create a pandas dataframe. Pickle this data and store it. Write another Python code to retrieve the data from the pickle.

**Course Outcome 3 (CO3): PCA and Cluster Analysis**

1. Write Python code to perform PCA on a pandas dataframe. Write code to create a scree plot.
2. Write Python code to do K-means clustering.

**Course Outcome 4 (CO4): Bayesian Analysis on Dataframes**

1. Write Python code to compute the posterior probability of a data set with Pymc3
2. Write a python code to evaluate the statistical correlation between variables in 5X5 random data set.

**Course Outcome 5 (CO5): Machine learning in Data Analysis**

1. Write python code to use Keras for training a CNN
2. Write Python code to read an RGB image and convert to gray scale and write the grayscale image in .jpg format.

**Course Outcome 5 (CO6): High Performance Computing Methods in Data analysis**

1. Write Python code to use numexpr for faster parallel computation
2. Write Python code with Ipython-parallel to perform parallel computing with 4 cores.

**SYLLABUS****Module 1: Overview of Data Analysis and Python**

Numpy and Scipy Python modules for data analysis. Reading and processing spreadsheets and csv files with Python using xlrd, xlwt and openpyxl. Data visualization with Matplotlib. Two dimensional charts and plots. Scatter plots with matplotlib. Three dimensional visualization using Mayavi module. Reading data from sql and mongodb databases with Python.

**Module 2: Big Data Arrays with Pandas**

Familiarization of the python pandas. Reading and writing pandas dataframes. Reading rows and columns from pandas dataframe. Handling NaN values. Reading and writing .txt, .csv, .pdf, .html and json files with pandas. Merging, concatenating and grouping of data frames. Use of pivot tables. Pickling of data frames in Python.

**Module 3: PCA and Cluster Analysis**

Singular value decomposition of a matrix/array. Eigen values and eigen vectors. Principal component analysis of a data frame. Scree plot. Dimensionality reduction with PCA. Loadings for principal components. Case study with Python. Cluster analysis. Hierarchical and K-means clustering. Interpretation of dendrograms.

**Module 4: Statistical Data Analysis**

Hypothesis testing. Bayesian analysis. Meaning of prior, posterior and likelihood functions. Use of pymc3 module to compute the posterior probability. MAP Estimation. Credible interval, conjugate distributions. Contingency table and chi square test. Kernel density estimation.

**Module 5: Machine Learning**

Supervised and unsupervised learning. Use of scikit-learn. Regression using scikit-learn. Deep learning with convolutional neural networks. Structure of CNN. Use of Keras and Tensorflow. Machine learning with pytorch. Reading and writing images with openCV. Case study of character recognition with MNIST dataset. High performance computing for machine learning. Use of numba, jit and numexpr for faster Python code. Use of Ipython-parallel.

**Text Books and References**

1. "Python Data Analytics", Fabio Nelli, Apress.
2. "Data Analysis from Scratch with Python", Peters Morgan, AI Sciences.
3. "Python for Data Analysis", Wes McKinny, O'Reilly.
4. "Ipython Interactive Computing and Visualization Cookbook", Cyrille Rossant, PACKT Open Source Publishing
5. "Deep Learning with Python", Francois Chollet, Manning

## Course Contents and Lecture Schedule

No	Topic	No. of Lectures
<b>1</b>	<b>Overview of Data Analysis and Python</b>	
1.1	Numpy and Scipy Python modules for data analysis.	2
1.2	Reading and processing spreadsheets and csv files with Python using xlrd, xlwt and openpyxl.	2
1.3	Data visualization with Matplotlib. Two dimensional charts and plots. Scatter plots with matplotlib. Three dimensional visualization using Mayavi module.	2
1.4	Reading data from sql and mongodb databases with Python	2
<b>2</b>	<b>Big Data Arrays with Pandas</b>	
2.1	Intro. To Python pandas	1
2.2	Reading and writing of data as pandas dataframes. Separating header, columns row etc and other manipulations	3
2.3	Reading data from different kind of files, Merging, concatenating and grouping of data frames. Use of pivot tables. Pickling	3
<b>3</b>	<b>PCA and Cluster Analysis</b>	
3.1	Singular value decomposition of a matrix/array. Eigen values and eigen vectors.	1
3.2	PCA, Scree plot. Dimensionality reduction with PCA. Loadings for principal components. Case study with Python. Cluster analysis.	3
3.3	Cluster analysis, dendrograms	2
<b>4</b>	<b>Statistical Data Analysis</b>	
4.1	Hypothesis testing. Bayesian analysis. Meaning of prior, posterior and likelihood functions. Use of pymc3 module to compute the posterior probability.	3
4.2	MAP Estimation. Credible interval, conjugate distributions. Contingency table and chi square test. Kernel density estimation.	3
4.3	Contingency table and chi square test. Kernel density estimation.	3
<b>5</b>	<b>Machine Learning</b>	
5.1	Supervised and unsupervised learning. Use of scikit-learn. Regression using scikit-learn.	2
5.2	Deep learning with convolutional neural networks. Structure of CNN.	2
5.3	Use of Keras and Tensorflow. Machine learning with pytorch. Case study of character recognition with MNIST dataset.	3
5.4	High performance computing for machine learning. Use of numba, jit and numexpr for faster Python code. Use of Ipython-parallel.	2

**Simulation Assignments**

1. Download the iris data set and read into a pandas data frame. Extract the header and replace with a new header. Extract columns and rows. Extract pivot tables. Filter the data based on the labels. Store a pivot table as a pickle and retrieve it.
2. For the same data set, perform principal component analysis. Observe the scree plot. Identify the principal components. Obtain a low dimensional data, with only the principal components and compute the mean square error between the original data and the approximated one. Compute the loadings for the principal components.
3. For the same data, perform hierarchical and K-means clustering with Python codes. Obtain dendrograms in each case and appreciate the clusters.
4. Download the MNIST letter data set. Construct a CNN network with appropriate layers using Keras and Tensorflow. Train the CNN with the MNIST data set. Appreciate the selection and use of training, test and cross-validation data sets. Save the model and weights and use the model to identify letter images. You may use openCV for reading images.
5. Write a Python script to generate alphanumeric images (26 upper case, 26 lowercase and 10 numbers each 12 point in size) of say 16X16 dimension out of windows .ttf files. Create 62 folders each containing a data set of every alphanumeric character. Create a new CNN with Keras and Tensorflow. Create a cross validation data set by taking 10 images out of every 62 folder. Use 80% of the total data for training and 20% for testing the CNN. Use an HPCC like system to train the model and save the model and weight. Test this model to recognize letter images. You may use openCV for reading images.
6. Repeat assignment 4 using pytorch instead of Keras
7. Repeat assignment 5 using pytorch instead of Keras



**Model Question Paper**

A P J Abdul Kalam Technological University

Sixth Semester B Tech Degree Examination

Course: ECT 332 Data Analysis

Time: 3 Hrs

Max. Marks: 100

**PART A***Answer All Questions*

- 1 Create a two dimensional array of real numbers using numpy. (3)  $K_3$   
Write Python code to pickle this data.
- 2 Write Python code to import mayavi module and perform 3-D (3)  $K_3$   
visualization of  $x^2 + y^2 + z^2 = 1$
- 3 Write Python code to generate a  $5 \times 5$  pandas data frame of random (3)  $K_3$   
numbers. Add a header to this dataframe.
- 4 Write Python code to concatenate two dataframes of same num- (3)  $K_3$   
ber of columns.
- 5 Write the expression for the singular value decomposition of a (3)  $K_3$   
matrix  $A$
- 6 Explain how principal components are isolated using scree plot. (3)  $K_1$
- 7 State Bayes theorem and explain the significance of the terms prior, (3)  $K_1$   
likelyhood and posterior.
- 8 Write Python code with pymc3 to realize a Bernoulli trial with (3)  $K_3$   
 $p(head) = 0.2$
- 9 Give the structure a convolutional neural network (3)  $K_1$
- 10 Compare supervised and unsupervised learning (3)  $K_1$

**PART B***Answer one question from each module. Each question carries 14 mark.***Module I**

- 11(A) Write Python code to read a spreadsheet in .xls format a text (8)  $K_3$   
file in .csv format and put these data into numpy arrays. in  
both cases, plot the second column against the first column  
using matplotlib
- 11(B) Write Python code to read tables from sql and mongodb (6)  $K_3$   
databases.

**OR**

- 12(A) Write Python code to create a normally distributed  $5 \times 5$  (8)  $K_3$   
random array and convert it into a matrix. Write code to

compute its inverse and transpose.

- 12(B) Write code to read files in .xlsx format using openpyxl (6)  $K_3$

### Module II

- 13(A) Write Python code to import a table in .xls format into a data frame. Remove all NaN values. (6)  $K_3$

- 13(B) Write Python code to generate 10 data frames of size  $5 \times 5$  of random numbers and use a *for loop* to concatenate them. Pickle the concatenated dataframe and store it. Write another code to retrieve the dataframe from the pickle. (8)  $K_3$

OR

- 14(A) Write Python code to read in a table from a pdf file into a pandas dataframe. Write code to remove the first two columns and write the rest of the dataframe as a json file. (8)  $K_3$

- 14(B) Explain the term pivot table. Create a pivot table from the above dataframe (6)  $K_3$

### Module III

- 15 Write Python code to read in table in .xls format, perform PCA analysis on it and produce the scree plot and loadings for the principal components. (14)  $K_3$

OR

16. Write Python code to perform hierarchial cluster analysis on a pandas dataframe. Explain how dendrograms can be used to classify data. (14)  $K_3$

### Module IV

- 17(A) Assume that you have a dataset with 57 data points of Gaussian distribution with a mean of 4 and standard deviation of 0.5. Using PyMC3, write Python code to compute:
- The posterior distribution
  - The prior distribution
  - The posterior predictive distribution
- (8)  $K_3$

- 17(B) Write a python code to find the Bayesian credible interval (6)  $K_3$   
in the above question. How is it different from confidence interval.

OR

- 18(A) Write a python code to evaluate the statistical correlation (8)  $K_3$   
between variables in  $10 \times 10$  random data set.
- 18(B) Compute the conjugate of the logarithmic function (6)  $K_3$   
 $f(x) = \ln x, x > 0.$

Module V

- 19(A) Explain the use of numba and numexpr in faster Python execution with (8)  $K_3$   
examples
- 19(B) Explain the use of Keras as a frontend for Tensorflow with (6)  $K_3$   
Python codes

OR

- 20(A) Explain the use of Ipython-parallel in parallel execution of (8)  $K_3$   
Python code with examples.
- 20(B) Explain with Python codes how openCV is used to read and (8)  $K_3$   
write images.

Estd.



2014



ECT342	EMBEDDED SYSTEMS	CATEGORY	L	T	P	CREDIT
		PEC	2	1	0	3

**Preamble:** This course aims to design an embedded electronic circuit and implement the same.

**Prerequisite:** ECT 203 Logic Circuit Design, ECT 202 Analog Circuits ,ECT 206 Computer Architecture and Microcontrollers

**Course Outcomes:** After the completion of the course the student will be able to

<b>CO 1 K2</b>	Understand and gain the basic idea about the embedded system.
<b>CO 2 K3</b>	Able to gain architectural level knowledge about the system and hence to program an embedded system.
<b>CO 3 K3</b>	Apply the knowledge for solving the real life problems with the help of an embedded system.

#### Mapping of course outcomes with program outcomes

	PO 1	PO 2	PO 3	PO 4	PO 5	PO 6	PO 7	PO 8	PO 9	PO 10	PO 11	PO 12
<b>CO 1</b>	3	3	2		1			2				2
<b>CO 2</b>	3	3	3		3			2				2
<b>CO 3</b>	3	3	3		3			2	3			2

#### Assessment Pattern

Bloom's Category		Continuous Assessment Tests		End Semester Examination
		1	2	
Remember	K1	10	10	10
Understand	K2	20	20	20
Apply	K3	20	20	70
Analyse				
Evaluate				
Create				

**Mark distribution**

<b>Total Marks</b>	<b>CIE</b>	<b>ESE</b>	<b>ESE Duration</b>
150	50	100	3 hours

**Continuous Internal Evaluation Pattern:**

Attendance	: 10 marks
Continuous Assessment Test (2 numbers)	: 25 marks
Assignment/Quiz/Course project	: 15 marks

**End Semester Examination Pattern:** There will be two parts; Part A and Part B. Part A contain 10 questions with 2 questions from each module, having 3 marks for each question. Students should answer all questions. Part B contains 2 questions from each module of which student should answer any one. Each question can have maximum 2 sub-divisions and carry 14 marks.

**Course Level Assessment Questions**

**Course Outcome 1 (CO1) : Understand the embedded system fundamentals and system design (K1).**

1. Give the challenges of embedded computing.
2. Give the structural description of embedded system.
3. What are the phases of EDLC ?.

**Course Outcome 2 (CO2): Understand the peripheral devices and their interfacing with the processor. (K2)**

1. Compare and contrast the PCI bus and PCI-X bus.
2. How the ROM memories are classified? Explain.
3. How the peripheral devices are connected with processors?

**Course Outcome 3 (CO3): To understand the ARM processor architecture and pipeline processor organization. (K3)**

1. Give the architecture of the ARM processor and explain the registers.
2. Explain the pipelined architecture of ARM processor.
3. Write an ARM assembly language program to print the sum of two numbers.

**Course Outcome 4 (CO4): To write programs in assembly and high level languages for ARM processor. (K3)**

1. Write a note on Thumb single register in ARM processor.
2. Briefly discuss about the Advanced Microcontroller Bus Architecture (AMBA).
3. What are the data types supported by ARM programming high level languages?

**Course Outcome 5 (CO5): To understand the basics of real time operating systems and their use in embedded systems. (K2)**

1. What are the functions of a Kernel?
2. Describe the process ,” Deadlock”
3. Give the features of a real time operating system.

## SYLLABUS

### **Module 1 : Introduction to Embedded Systems( 06 Hours )**

#### **1.1 Complex Systems and Microprocessors**

Embedding Computers, Characteristics of Embedded Computing Applications, Application of Microprocessors, The Physics of Software, Challenges in Embedded Computing System, Characteristics and quality attributes of an embedded system, Performance in Embedded Computing

#### **1.2 The Embedded System Design Process**

Requirements, Specification , Architecture Design, Designing Hardware and Software Components ,System Integration.

#### **1.3 Formalisms for System Design**

Structural Description, Behavioral Description, An embedded system design example.

#### **1.4 Embedded product development cycle (EDLC)**

Different phases of EDLC, EDLC models

### **Module 2 : Embedded system interfacing and peripherals (06 Hours)**

#### **2.1 Communication devices**

Serial Communication Standards and Devices - UART, HDLC and SPI. Serial Bus Protocols - I<sup>2</sup>C Bus, CAN Bus and USB Bus. Parallel communication standards ISA, PCI and PCI-X Bus.

#### **2.2 Memory**

Memory devices and systems – ROM-Flash, EEPROM, RAM-SRAM, DRAM, Cache memory, memory mapping and addresses, memory management unit– DMA .

**2.3 I/O Device**

Interrupts--Interrupt sources, recognizing an interrupt, ISR – Device drivers for handling ISR, Shared data problem, Interrupt latency.

**Module 3 : ARM Processor fundamentals (07 Hours )****3.1 ARM Processor architecture**

The Acorn RISC Machine, Architectural inheritance, The ARM programmer's model, ARM development tools.

**3.2 ARM Assembly Language Programming**

Data processing instructions, Data transfer instructions, Control flow instructions, writing simple assembly language programs.

**3.3 ARM Organization and Implementation**

Three stage pipeline ARM organization, Five stage pipeline ARM organization, ARM instruction execution, ARM implementation, The ARM coprocessor interface.

**Module 4: ARM Programming (10 Hours)****4.1 Architectural Support for High-Level Languages**

Abstraction in software design, Data types, Floating-point data types, The ARM floating-point architecture, Expressions, Conditional statements, Loops, Functions and procedures, Use of memory, Run-time environment.

**4.2 The Thumb Instruction Set**

The Thumb bit in the CPSR, The Thumb programmer's model, Thumb branch instructions, Thumb software interrupt instruction, Thumb data processing instructions, Thumb single register data transfer instructions, Thumb multiple register data transfer instructions, Thumb breakpoint instruction, Thumb implementation, Thumb applications.

**4.3 Architectural Support for System Development**

The ARM memory interface, The Advanced Microcontroller Bus Architecture (AMBA).

**4.4 Programming**

Assembly and C language programming applications of embedded systems.

**Module 5: Real Time Operating Systems (07 Hours)****5.1 Operating system basics**

Kernel, types of operating systems.

**5.2 Real time operating systems**

Tasks, process, threads, multiprocessing and multi-tasking, task scheduling, types, threads and process scheduling, task communication, task synchronization, device drivers, choosing an RTOS.

**Text Books**

1. 1. Raj kamal, Embedded Systems Architecture, Programming and Design, TMH, 2003
2. K.V. Shibu, Introduction to Embedded Systems, 2e, McGraw Hill Education India, 2016.
3. Wayne Wolf, Computers as Components: Principles of Embedded Computing System Design, Morgan Kaufman Publishers - Elsevier 3ed, 2008
4. Steve Furber, ARM system-on-chip architecture, Addison Wesley, Second Edition, 2000

**Reference Books**

1. David E. Simon, An Embedded Software Primer, Pearson Education Asia, First Indian Reprint 2000.
2. Steve Heath, Embedded Systems Design, Newnes – Elsevier 2ed, 2002
3. Andrew N. Sloss, Dominic Symes, Chris Wright, ARM System Developer's Guide Designing and Optimizing System Software, Morgan Kaufmann Publishers 2004
4. Frank Vahid and Tony Givargis, Embedded Systems Design – A Unified Hardware / Software Introduction, John Wiley, 2002.
5. Tammy Noergaard, Embedded Systems Architecture, A Comprehensive Guide for Engineers and Programmers, Newnes – Elsevier 2ed, 2012
6. Iyer - Embedded Real time Systems, 1e, McGraw Hill Education New Delhi, 2003
7. Lyla B. Das, Embedded Systems: An Integrated Approach, 1/e , Lyla B. Das, Embedded Systems, 2012

**Course Contents and Lecture Schedule**

No	Topic	No. of Lectures
<b>1</b>	<b>Introduction to Embedded Systems</b>	
1.1	Complex Systems and Microprocessors	2
1.2	The Embedded System Design Process	1
1.3	Formalisms for System Design	2
1.4	Embedded product development cycle (EDLC)	1
<b>2</b>	<b>Embedded system interfacing and peripherals</b>	
2.1	Communication devices	3
2.2	Memory	2
2.3	I/O Device	2

<b>3</b>	<b>ARM Processor fundamentals</b>	
3.1	ARM Processor architecture	2
3.2	ARM Assembly Language Programming	3
3.3	ARM Organization and Implementation	2
<b>4</b>	<b>ARM Programming</b>	
4.1	Architectural Support for High-Level Languages	2
4.2	The Thumb Instruction Set	3
4.3	Architectural Support for System Development	2
4.4	Programming	3
<b>5</b>	<b>Real Time Operating Systems</b>	
5.1	Operating system basics	2
5.2	Real time operating systems	5

#### Simulation Assignments:

1. At least one assignment should be of programming (Both assembly and C languages) of embedded processor with simulation tools like Keil, Eclipse.
2. Another assignment should be an embedded system design mini project.

Programming assignments can be the following

- (a) Print "HELLO WORLD" or any text
- (b) Data transfer, copy operations
- (c) Arithmetic operations
- (d) Sorting operations
- (e) input/output control
- (f) programs using functions
- (g) Interrupts and ISR
- (h) controller design

Mini project can be done in the following areas.

- (a) Elevator controller design
- (b) Chocolate vending machine design
- (c) Industrial controller using sensors
- (d) IOT applications using sensors, communication devices and actuators

**Model Question paper****APJ ABDUL KALAM TECHNOLOGICAL UNIVERSITY**SIXTH SEMESTER B.TECH DEGREE EXAMINATION, (**Model Question Paper**)**Course Code: ECT342****Course Name: EMBEDDED SYSTEM DESIGN**

Max. Marks: 100

Duration: 3 Hours

**PART A**

(Answer ALL Questions. Each Question Carries 3 Marks.)

1. Define an embedded system
2. Write any 3 challenges of embedded system design
3. Explain how an RS232 device is interfaced to a processor
4. What is interrupt latency?
5. Write the contents of CPSR register of ARM processor and their use.
6. Draw the five stage pipeline architecture of ARM processor
7. What is the use of thumb instruction set in ARM processor?
8. What a note on ARM memory interface
9. What is a real time operating system?
10. What are tasks, processes and threads? [10 X 3= 30]

**PART – B**

(Answer one question from each module; each question carries 14 marks)

**Module – I**

11. (a) What are the characteristics of an embedded system? Explain. [07 Marks]  
(b) Explain the different phases of EDLC. [07 Marks]

**OR**

12. (a) Write different steps involved in the embedded system design process. [07Marks]  
(b) Explain the structural description of embedded system design. [07 Marks]

**Module – II**

13. (a) What is serial and parallel port communication? Explain with the help of necessary diagrams. [07 Marks]

(b) What is interrupt? How interrupts are handled in a processor? Explain ISR.[07 Marks]

**OR**

14. (a) With the help of a diagram show how ROM and RAM are interfaced to a processor. Explain the read/write processes. [07 Marks]

(b) Explain how a memory management unit is used in a processor. What are its uses? What is DMA ? [07 Marks]

**Module – III**

15. (a) Write a note on ARM processor architecture and its registers. [07 Marks]

(b) Write a note on data processing and data transfer instructions with the help of examples [07 Marks]

**OR**

16. (a) What is pipeline architecture? Explain how an ARM instruction is executed in a 5 stage pipeline processor with the help of an example. [08 Marks]

(b) Write an ARM assembly language program to print text string “Hello World”. [06 Marks]

**Module – IV**

17. (a) Explain ARM floating point architecture and discuss how floating point numbers are handled [07 Marks]

(b) Write a note on Thumb single register and multiple register data transfer instructions with the help of examples. [07 Marks]

**OR**

18. (a) What is Thumb instruction set? Why it is used? Explain Thumb programmers model. [07 Marks]

(b) Draw the block diagram of AMBA architecture. What are the different types of buses used in the architecture? [07 Marks]

**Module V**

19. (a) What are the different services of Kernel? Explain different types of Kernels. [07Marks]



(b) Explain pre-emptive and non-pre-emptive scheduling algorithms with the help of an example. [07 Marks]

**OR**

20. (a) What are the basic functions of real time Kernel? Explain. [07 Marks]

(b) Write a note on the following (a) shared memory (b) message passing (c) deadlock [07 Marks]

APJ ABDUL KALAM  
TECHNOLOGICAL  
UNIVERSITY

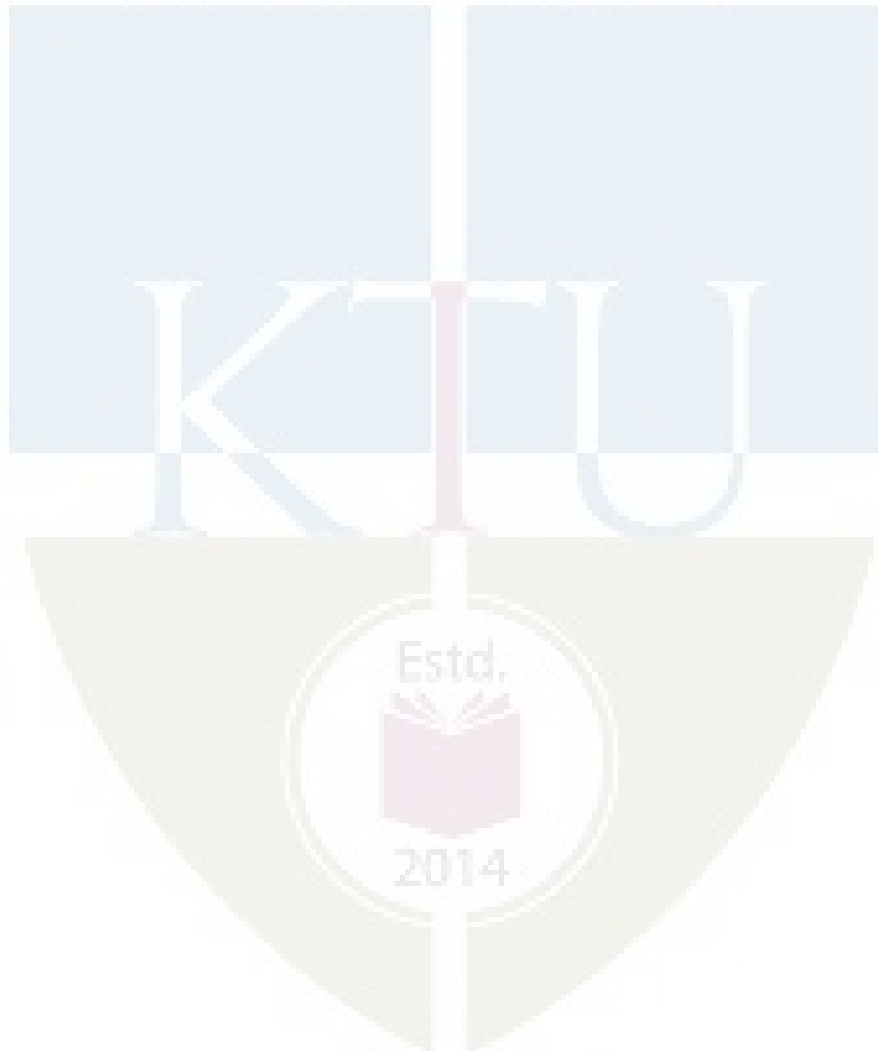

ECT352	DIGITAL IMAGE PROCESSING	CATEGORY	L	T	P	CREDIT
		PEC	2	1	0	3

**Preamble:** This course aims to develop the skills for methods of various transformation and analysis of image enhancement, image reconstruction, image compression, image segmentation and image representation.

**Prerequisite:** ECT 303 Digital Signal Processing

**Course Outcomes:** After the completion of the course the student will be able to

CO 1	Distinguish / Analyse the various concepts and mathematical transforms necessary for image processing
CO 2	Differentiate and interpret the various image enhancement techniques
CO 3	Illustrate image segmentation algorithm
CO 4	Understand the basic image compression techniques

**Mapping of course outcomes with program outcomes**

	PO 1	PO 2	PO 3	PO 4	PO 5	PO 6	PO 7	PO 8	PO 9	PO 10	PO 11	PO 12
CO 1	3	3	2		1							2
CO 2	3	3	2		1							2
CO 3	3	3	3		1							2
CO 4	3	3	3		1							2

**Assessment Pattern**

Bloom's Category		Continuous Assessment Tests		End Semester Examination
		1	2	
Remember	K1	10	10	10
Understand	K2	20	20	20
Apply	K3	20	20	70
Analyse	K4			
Evaluate				
Create				

**Mark distribution**

Total Marks	CIE	ESE	ESE Duration
150	50	100	3 hours

**Continuous Internal Evaluation Pattern:**

Attendance: 10 marks

Continuous Assessment Test (2 numbers) : 25 marks

Assignment/Quiz/Course project : 15 marks

**End Semester Examination Pattern:** There will be two parts; Part A and Part B. Part A contain 10 questions with 2 questions from each module, having 3 marks for each question. Students should answer all questions. Part B contains 2 questions from each module of which student should answer any one. Each question can have maximum 2 sub-divisions and carry 14 marks. The questions must have 50% representation from theory, and 50% representation from logical/numerical/derivation/proof.

**Course Level Assessment Questions**

**Course Outcome 1 (CO1):** Analyze the various concepts and restoration techniques for image processing

1. For the given image check whether pixel P and Q have 8 connectivity.
2. Find filtered image using median filter.
3. Explain Weiner filtering.

**Course Outcome 2 (CO2):** Differentiate and interpret the various image enhancement techniques

1. Classify different image enhancement process. Differentiate between spatial domain and frequency domain techniques of image enhancement.
2. What is histogram equalisation? Briefly discuss the underlying logic behind histogram equalisation.
3. Apply mean and median filters over a given image.

**Course Outcome 3 (CO3):** Illustrate image segmentation algorithm

1. Name two basic approaches of image segmentation and mention their differences.
2. How can you decide optimal thresholds when the image contains a background and several foreground objects? Write down a corresponding algorithm.
3. Write down the region growing algorithm. What are its advantages and disadvantages?

**Course Outcome 4 (CO4):** Analyze basic image compression techniques

1. What do you mean by compression ratio? Do you consider that lower compression ratio ensures better images upon reproduction?
2. How can achievable compression ratio to be determined from image histogram?
3. Mention the steps of lossy and lossless JPEG compression

**SYLLABUS****Module 1**

**Digital Image Fundamentals:** Image representation, basic relationship between pixels, elements of DIP system, elements of visual perception-simple image formation model. Vidicon and Digital Camera working principles Brightness, contrast, hue, saturation, mach band effect

**Colour image fundamentals-**RGB, CMY, HIS models, 2D sampling, quantization.

**Module 2**

**Review of matrix theory:** row and column ordering- Toeplitz, Circulant and block matrix

**2D Image transforms:** DFT, its properties, Walsh transform, Hadamard transform, Haar transform, DCT, KL transform and Singular Value Decomposition.

**Image Compression:** Need for compression, Basics of lossless compression – bit plane coding, run length encoding and predictive coding, Basics of lossy compression – uniform and non-uniform quantization techniques used in image compression, Concept of transform coding, JPEG Image compression standard.

**Module 3**

**Image Enhancement:** Spatial domain methods: point processing- intensity transformations, histogram processing, image subtraction, image averaging. Spatial filtering- smoothing filters, sharpening filters.

Frequency domain methods: low pass filtering, high pass filtering, homomorphic filter

**Module 4**

**Image Restoration:** Degradation model, Unconstraint restoration- Lagrange multiplier and constraint restoration

Inverse filtering- removal of blur caused by uniform linear motion, Weiner filtering,

Geometric transformations-spatial transformations

**Module 5**

**Image segmentation:** Classification of Image segmentation techniques, region approach, clustering techniques. Segmentation based on thresholding, edge based segmentation. Classification of edges, edge detection, Hough transform, active contour.

**Text Books**

1. Gonzalez Rafael C, Digital Image Processing, Pearson Education, 2009
2. S Jayaraman, S Esakkirajan, T Veerakumar, Digital image processing, Tata Mc Graw Hill, 2015

**Reference Books**

1. Jain Anil K , Fundamentals of digital image processing: , PHI,1988
2. Kenneth R Castleman , Digital image processing:, Pearson Education,2/e,2003
3. Pratt William K , Digital Image Processing: , John Wiley,4/e,2007

**Course Contents and Lecture Schedule**

No.	Topic	No. of Lectures
<b>1</b>	<b>Digital Image Fundamentals</b>	
1.1	Image representation, basic relationship between pixels, elements of DIP system, elements of visual perception-simple image formation model	3
1.2	Vidicon and Digital Camera working principles	1
1.3	Brightness, contrast, hue, saturation, mach band effect	1
1.4	<b>Colour image fundamentals</b> -RGB, CMY, HIS models	1
1.5	2D sampling, quantization.	1
<b>2</b>	<b>Review of matrix theory</b>	
2.1	Row and column ordering- Toeplitz, Circulant and block matrix	2
2.2	<b>2D Image transforms</b> : DFT, its properties, Walsh transform, Hadamard transform, Haar transform	3
2.3	DCT, KL transform and Singular Value Decomposition.	3
2.4	<b>Image Compression:</b> Need for compression, Basics of lossless compression – bit plane coding, run length encoding and predictive coding, Basics of lossy compression – uniform and non-uniform quantization techniques used in image compression, Concept of transform coding, JPEG Image compression standard..	2
<b>3</b>	<b>Image Enhancement</b>	
3.1	Spatial domain methods: point processing- intensity transformations, histogram processing, image subtraction, image averaging	2
3.2	Spatial filtering- smoothing filters, sharpening filters	1
3.3	Frequency domain methods: low pass filtering, high pass filtering, homomorphic filter.	2
<b>4</b>	<b>Image Restoration</b>	
4.1	Degradation model, Unconstraint restoration- Lagrange multiplier and constraint restoration	2
4.2	Inverse filtering- removal of blur caused by uniform linear motion, Weiner filtering	2
4.3	Geometric transformations-spatial transformations	2
<b>5</b>	<b>Image segmentation</b>	
5.1	Classification of Image segmentation techniques, region approach, clustering techniques	2
5.2	Segmentation based on Thresholding, edge based segmentation	2
5.3	Classification of edges, edge detection, Hough transform, active contour	3

**Simulation Assignments**

The following simulations be done in Scilab/ Matlab/ LabView:

1. Read Image data into the workspace.
2. Determine various transforms using matlab functions.
3. Detect and measure circular objects in an image.
4. Adjust the contrast of the given image.
5. Filter images using predefined filter.
6. Create degraded images affected by motion blur and noise by simulating the models for both. Apply inverse filtering and Weiner filtering methods to the simulated images and compare their performance.
7. Detect an object against the background using various edge detection algorithms and compare their performance.
8. Create a histogram for a gray scale image.
9. Create image at various compression level.
10. Use texture segmentation to identify region based on their texture.

**Model Question paper****APJ ABDUL KALAM TECHNOLOGICAL UNIVERSITY**SIXTH SEMESTER B.TECH DEGREE EXAMINATION, (**Model Question Paper**)**Course Code: ECT352****Course Name: DIGITAL IMAGE PROCESSING**

Max. Marks: 100

Duration: 3 Hours

**PART A**

Answer all questions, each carries 3 marks.

1. Give mathematical representation of digital images? Write down the names of different formats used. K2
2. Explain mach band effect. K2
3. What is SVD? Explain its applications in digital image processing. K3
4. Write the similarity and difference between Hadamard and Walsh transforms K3
5. What are the advantages and disadvantages of block processing K2
6. Name the role of point operators in image enhancement K2
7. What is median filter? Explain the operation in 2D noise image with salt and pepper noise K3
8. Distinguish between linear and nonlinear image restoration. K3
9. Mention the use of derivative operation in edge detection. K4
10. The Prewitt edge operator is much better than Robert operator. Why? Give the matrix. K3

**PART B****Answer any one full questions, from each module carries 14 marks.**

## Module 1

1. a) State and explain the 2D sampling theorem. Explain how aliasing errors can be eliminated? (7 marks)
- b) Define the terms brightness, contrast, hue and saturation with respect to a digital image. Explain the terms False contouring and Machband effect. (K1 – CO1) (7 marks)

OR

2. a) Explain elements of visual perception simple image formation model in detail (K1 – CO1) (8 marks)
- b) Explain various color image models and its transformations (K1 - CO1) (6 marks)

## Module 2

3. a) Explain the difference between DST and DCT. (K2 - CO1) (4 marks)
- b) Compute the 2D DFT of the 4x4 gray scale image given below. (K3-CO1) (10 marks)

$$f(x, y) = \begin{bmatrix} 1 & 1 & 1 & 1 \\ 1 & 1 & 1 & 1 \\ 1 & 1 & 1 & 1 \\ 1 & 1 & 1 & 1 \end{bmatrix}$$

OR

4. a) Construct a Harr transform matrix for N=4. (4 marks) (K3-CO1)  
 b) Compute the 8-point DCT for following data  $X = \{2, 4, 6, 8, 10, 6, 4, 2\}$ . (10 marks)

Module 3

5. a) List histogram image enhancement techniques? Explain each one in detail. (10 marks)  
 K2-CO2  
 b) Write a note on color image enhancement. (K2-CO2) (4 marks)

OR

6. a) Describe the following in detail (i) Histogram equalization (ii) LPF and HPF in image enhancement (iii) high boost filters (10 marks)

Module 4

7. a) Assume 4x4 image and filter the image using median filter of 3x3 neighbourhood. Use replicate padding. (K3—CO1) (8 marks)  
 b) Explain the digital image restoration. (K1—CO1) (6 marks)

OR

8. a) Explain inverse filtering with necessary equations. (K1-CO1) (6 marks)  
 b) Differentiate various noise models. (K2-CO1) (8 marks)

Module 5

9. a) Explain the active contour algorithm for image segmentation any four geometric transformations on an image. (K2-CO3) (7 marks)  
 c) Assume 4x4 image and filter the image using median filter of 3x3 neighbourhoods. Use replicate padding (K3—CO1) (7 marks)

OR

10. a) Explain global, adaptive and histogram based thresholding in detail. (7 marks)  
 c) Explain Hough transform in detail (7 marks)



ECT362	INTRODUCTION TO MEMS	CATEGORY	L	T	P	CREDIT
		PEC	2	1	0	3

**Preamble:** This course introduces students to the rapidly emerging, multi-disciplinary, and exciting field of Micro Electro Mechanical Systems.

**Prerequisite:** EST130-Basics of Electrical and Electronics Engineering, EST 100-Engineering Mechanics

### Course Outcomes

CO1	Describe the working principles of micro sensors and actuators
CO2	Identify commonly used mechanical structures in MEMS
CO3	Explain the application of scaling laws in the design of micro systems
CO4	Identify the typical materials used for fabrication of micro systems
CO5	Explain the principles of standard micro fabrication techniques
CO6	Describe the challenges in the design and fabrication of Micro systems

### Mapping of course outcomes with program outcomes

	PO1	PO2	PO3	PO4	PO5	PO6	PO7	PO8	PO9	PO10	PO11	PO12
CO1	3	3										
CO2	3	3										
CO3	3	3										
CO4	3	3	2									
CO5	3	3										
CO6	3	3										

### Assessment Pattern

Bloom's Category	Continuous Assessment Tests		End Semester Examination
	1	2	
Remember	10	10	20
Understand	30	30	60
Apply	10	10	20
Analyse			
Evaluate			
Create			

### Mark distribution

Total Marks	CIE	ESE	ESE Duration
150	50	100	3 hours

**Continuous Internal Evaluation Pattern:**

Attendance	: 10 marks
Continuous Assessment Test (2 numbers)	: 25 marks
Assignment/Quiz/Course project	: 15 marks

**End Semester Examination Pattern:** There will be two parts; Part A and Part B. Part A contain 10 questions with 2 questions from each module, having 3 marks for each question. Students should answer all questions. Part B contains 2 questions from each module of which student should answer any one. Each question can have maximum 2 sub-divisions and carry 14 marks.

**Course Level Assessment Questions**

**Course Outcome 1 (CO1): Describe the working principles of micro sensors and actuators**

1. Explain the principle of operation of two types of micro-accelerometers
2. Explain with relevant examples how the principle of electrostatics may be used for the design of MEMS based sensors and actuators.
3. Explain how smart materials can be used for the design of MEMS based sensors and actuators.

**Course Outcome 2 (CO2): Identify commonly used mechanical structures in MEMS**

1. Explain the purpose of micro cantilevers in MEMS systems. What is the relevance of spring constant ( $k$ ) of a mechanical structure in micro system design?
2. Derive the expression for the magnitude of applied bending moment with reference to pure bending of longitudinal beams.
3. Explain how plates and diaphragms can be used for the design

**Course Outcome 3(CO3): Explain the application of scaling laws in the design of micro systems**

1. Explain force scaling vector, what information does it provide to a MEMS designer?
2. Derive equations for acceleration  $a$ , time  $t$  and power density  $P/V$  based on the Trimmer Force Scaling Vector?
3. Explain why electrostatic actuation is preferred over electromagnetic actuation at the micro-scale.

**Course Outcome 4 (CO4): Identify the typical materials used for fabrication of micro systems**

1. State the relevant properties of Silicon Carbide and Silicon Nitride for use in Microsystems.
2. Explain why Silicon evolved as the ideal substrate material for MEMS fabrication.
3. Explain with examples the advantages of use of polymers in micro systems fabrication?

**Course Outcome 5 (CO5): Explain the principles of standard micro fabrication techniques**

1. Explain the steps involved in photolithography. State the chemicals used in each of the stages along with the operating conditions.
2. Explain the criteria for choice of surface or bulk micromachining techniques in the design of micro systems.
3. Explain with block diagram the steps in LIGA process. State two advantages of LIGA process over other micro machining techniques.

**Course Outcome 6 (CO6): Describe the challenges in the design, fabrication and packaging of Micro systems**

1. Explain the challenges involved in the packaging of Microsystems as compared to microelectronic devices
2. Discuss the various fabrication challenges associated with surface micromachining.

**SYLLABUS****MODULE I**

MEMS and Microsystems: Applications – multidisciplinary nature of MEMS – principles and examples of Micro sensors and micro actuators – micro accelerometer –comb drives - Micro grippers – micro motors, micro valves, micro pumps, Shape Memory Alloys.

Actuation and Sensing techniques: Thermal sensors and actuators, Electrostatic sensors and actuators, Piezoelectric sensors and actuators, magnetic actuators

**MODULE II**

Review of Mechanical concepts: Stress, Strain, Modulus of Elasticity, yield strength, ultimate strength – General stress strain relations – compliance matrix. Overview of commonly used mechanical structures in MEMS - Beams, Cantilevers, Plates, Diaphragms – Typical applications

Flexural beams: Types of Beams, longitudinal strain under pure bending – Deflection of beams – Spring constant of cantilever – Intrinsic stresses

**MODULE III**

Scaling laws in miniaturization - scaling in geometry, scaling in rigid body dynamics, Trimmer force scaling vector, scaling in electrostatic and electromagnetic forces, scaling in electricity and fluidic dynamics, scaling in heat conducting and heat convection.

Materials for MEMS – Silicon – Silicon compounds – Silicon Nitride, Silicon Dioxide, Silicon carbide, Poly Silicon, GaAs , Silicon Piezo resistors. Polymers in MEMS – SU-8, PMMA, PDMS, Langmuir – Blodgett Films.

**MODULE IV**

Micro System fabrication – Photolithography – Ion implantation- Diffusion – Oxidation – Chemical vapour deposition – Etching

Overview of Micro manufacturing – Bulk micro manufacturing, Surface micro machining , LIGA process –Microstereo lithography

**MODULE V**

Micro system Packaging: general considerations in packaging design – Levels of Micro system packaging. Bonding techniques for MEMS: Surface bonding, Anodic bonding, Silicon - on - Insulator, wire bonding, Sealing – Assembly of micro systems.

Overview of MEMS areas : RF MEMS, BioMEMS, MOEMS, NEMS

**Text Books:**

1. Chang Liu, Foundations of MEMS, Pearson 2012
2. Tai-Ran Hsu, MEMS and Microsystems Design and Manufacture, TMH, 2002

**Reference Books:**

1. Chang C Y and Sze S. M., VLSI Technology, McGraw-Hill, New York, 2000
2. Julian W Gardner, Microsensors: Principles and Applications, John Wiley & Sons, 1994
3. Mark Madou, Fundamentals of Micro fabrication, CRC Press, New York, 1997
4. Stephen D. Senturia, Microsystem design, Springer (India), 2006.
5. Thomas B. Jones, Electromechanics and MEMS, Cambridge University Press, 2001
6. Gregory T.A. Kovacs, Micromachined Transducers Sourcebook, McGraw Hill, 1998

**Course Contents and Lecture Schedule**

No	Topic	No. of Lectures
1.1	Introduction to MEMS and Microsystems	1
1.2	Applications – multidisciplinary nature of MEMS – principles and examples of Micro sensors and micro actuators – micro accelerometer, comb drives -	1
1.3	Micro grippers – micro motors,	1
1.4	micro valves, micro pumps, Shape Memory Alloys.	1
1.5	Actuation and Sensing techniques : Thermal sensors and actuators,	1
1.6	Electrostatic sensors and actuators	1
1.7	Piezoelectric sensors and actuators,	1
1.8	magnetic actuators	1

2.1	Review of Mechanical concepts: Stress, Strain, Modulus of Elasticity, yield strength, ultimate strength	1
2.2	General stress strain relations – compliance matrix.	1
2.3	Overview of commonly used mechanical structures in MEMS - Beams, Cantilevers, Plates, Diaphragms – Typical applications	1
2.4	Flexural beams: Types of Beams, longitudinal strain under pure bending	2
2.5	Deflection of beams – Spring constant of cantilever, Intrinsic stresses	1
3.1	Scaling laws in miniaturization - scaling in geometry, scaling in rigid body dynamics, Trimmer force scaling vector,	2
3.2	scaling in electrostatic and electromagnetic forces	1
3.3	scaling in electricity and fluidic dynamics,	1
3.4	scaling in heat conducting and heat convection	1
3.5	Materials for MEMS – Silicon – Silicon compounds- Silicon Nitride	1
3.6	Silicon Dioxide, Silicon carbide	1
3.7	Poly Silicon, GaAs , Silicon Piezo resistors	1
3.8	Polymers in MEMS – SU-8, PMMA,	1
3.9	PDMS, Langmuir – Blodgett Film	1
4.1	Micro System fabrication, Photolithography– Ion implantation	2
4.2	Diffusion, Oxidation	1
4.3	Chemical vapour deposition, Etching	1
4.4	Overview of Micro manufacturing – Bulk micro manufacturing,	1
4.5	Surface micro machining	1
4.6	LIGA process	1
4.7	Microstereo lithography	1
5.1	Micro system Packaging: general considerations in packaging design	1
5.2	Levels of Micro system packaging	1
5.3	Bonding techniques for MEMS : Surface bonding , Anodic bonding	1
5.4	Silicon - on - Insulator , wire bonding	1
5.5	Sealing – Assembly of micro systems	1
5.6	Overview of MEMS areas : RF MEMS, BioMEMS, MOEMS, NEMS	1

**A P J Abdul Kalam Technological University**  
 Sixth Semester B Tech Degree Examination  
**Course: ECT 362 Introduction to MEMS**  
**Time: 3 Hrs Max. Marks: 100**

**PART A**

*Answer All Questions*

- |    |  |   |
|----|--|---|
| 1  | State an example to justify the multidisciplinary nature of MEMS   | 3 |
| 2  | State three applications of MEMS devices in the automotive industry  | 3 |
| 3  | Define normal stress and strain, how it is different from shear stress and strain  | 3 |
| 4  | Determine the stress in the longitudinal direction of a Silicon rod with rectangular cross section is pulled on both ends with a force of 10mN. The dimensions of the rod being 1 mm X 100 $\mu$ m X 50 $\mu$ m. | 3 |
| 5  | Define the Trimmer force scaling vector  | 3 |
| 6  | State one application each of PDMS and PMMA in MEMS fabrication  | 3 |
| 7  | Discuss the criteria for selecting materials for the masks used in etching   | 3 |
| 8  | Define etch stop? State the different methods used to stop etching   | 3 |
| 9  | State the various levels of micro system packaging   | 3 |
| 10 | State two applications of NEMS   | 3 |

**PART B**

*Answer one question from each module. Each question carries 14 marks.*

**Module I**

- |       |  |   |
|-------|--|---|
| 11(A) | Sketch and explain the working of a silicon capacitive accelerometer attached to a comb drive  | 6 |
| 11(B) | Explain the operating principle of piezoelectric sensors and actuators with relevant sketches. | 8 |

**OR**

- |       |  |   |
|-------|--|---|
| 12(A) | Explain the operating principle of thermal bimorphs with neat sketches. State any two applications of thermal sensors. | 8 |
| 12(B) | Explain the principle of operation of the following micro sensors (i) Comb drives (ii) Shape Memory Alloys             | 6 |

**Module II**

- |       |   |   |
|-------|---|---|
| 13(A) | Determine the force constant associated with the two beams (a) and (b) shown in figure below. Which is stiffer, justify with arguments. | 8 |
|-------|---|---|

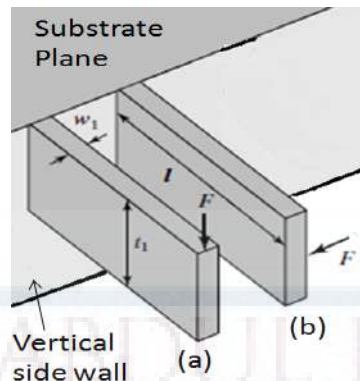

- 13(B) Explain with neat sketches the longitudinal strain experienced by segment of beam (with rectangular cross-section) under pure bending. 6

**OR**

- 14(A) Explain the general stress strain relationship and arrive at the compliance matrix 8
- 14(B) Explain with neat sketches the type of mechanical beams and boundary conditions associated with supports 6

### Module III

- 15(A) Explain in the light of scaling, assuming a 10 times reduction of size of the actuator. Which of the electrostatic and electromagnetic forces are best suited for micro device actuation. 8
- 15(B) State three relevant properties of Silicon Carbide and Silicon Nitride for use in Microsystems 6

**OR**

- 16(A) Explain various scaling laws in miniaturization 6
- 16(B) State the constraints in pumping fluids in micro channels. What pumping scheme is usually used in micro fluidics, state one example? 8

### Module IV

- 17(A) Explain the steps involved in photolithography. State the chemicals used in each of the stages along with the operating conditions 6
- 17(B) Compare and contrast various micro manufacturing techniques 8

**OR**

- 18(A) Describe the various mechanical problems associated with surface micromachining 6
- 18(B) Explain the LIGA process associated with MEMS fabrication 8

### Module V

- 19(A) Explain the following bonding techniques with figures a) Silicon-on-Insulator b) Wire bonding 8
- 19(B) Explain the challenges involved in BioMEMS. List three applications of BioMEMS. 8

**OR**

- 20(A) Explain with diagrams any two applications of RFMEMS 8
- 20(B) Explain the challenges involved in designing packages for micro systems 6

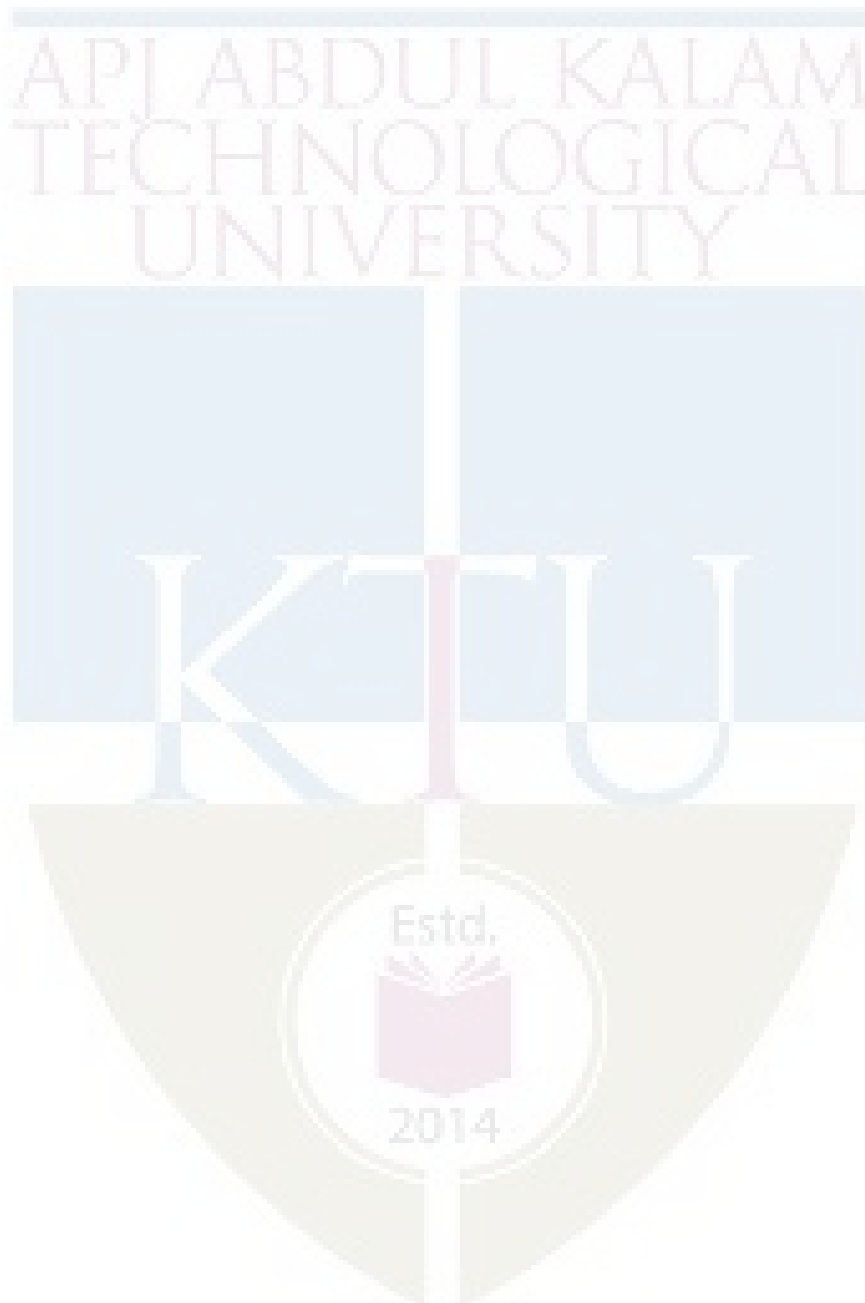



ECT372	QUANTUM COMPUTING	CATEGORY	L	T	P	CREDIT
		PEC	2	1	0	3

**Preamble:** Quantum computers are not yet built. If such machines become a reality, they will fundamentally change how we perform calculations, and the implications on many applications (including communications and computer security) will be tremendous. This course aims to provide a first introduction to quantum computing with a general understanding of how quantum mechanics can be applied to computational problems. It highlights the paradigm change between conventional computing and quantum computing, and introduce several basic quantum algorithms.

**Prerequisite:** MAT101 Linear Algebra and Calculus

**Course Outcomes:** After the completion of the course the student will be able to

<b>CO 1 K2</b>	Explain the basic constructs in linear algebra needed to build the concepts of quantum computing
<b>CO 2 K2</b>	Relate the postulates of quantum mechanics for computation and illustrate/ demonstrate quantum measurement
<b>CO 3 K3</b>	Identify quantum gates and build quantum circuit model in which most of the quantum algorithms are designed.
<b>CO 4 K4</b>	Analyse and design quantum algorithms and grasp the advantage they offer over classical counterparts.

#### Mapping of course outcomes with program outcomes

	PO 1	PO 2	PO 3	PO 4	PO 5	PO 6	PO 7	PO 8	PO 9	PO 10	PO 11	PO 12
CO1	3	3										2
CO2	3	3										2
CO3	3	3	3									2
CO4	3	3	3	2								2

#### Assessment Pattern

Bloom's Category		Continuous Assessment Tests		End Semester Examination
		1	2	
Remember	K1	10	10	10
Understand	K2	20	20	20
Apply	K3	20	10	50
Analyse	K4		10	20
Evaluate				
Create				

**Mark distribution**

Total Marks	CIE	ESE	ESE Duration
150	50	100	3 hours

**Continuous Internal Evaluation Pattern:**

Attendance	: 10 marks
Continuous Assessment Test (2 numbers)	: 25 marks
Assignment/Quiz/Course project	: 15 marks

**End Semester Examination Pattern:** There will be two parts; Part A and Part B. Part A contain 10 questions with 2 questions from each module, having 3 marks for each question. Students should answer all questions. Part B contains 2 questions from each module of which student should answer any one. Each question can have maximum 2 sub-divisions and carry 14 marks.

**Course Level Assessment Questions****Course Outcome 1 (CO1): Explain the basic constructs in linear algebra needed to build the concepts of quantum computing (K2)**

1. Summarise the basic operators and matrices required for understanding the quantum computing concepts.
2. Find the Eigen values and Eigen vectors of Pauli matrices.
3. Explain spectral decomposition and Spectral theorem. State the spectral theorem for Hermitian operator.
4. Show the matrix representation of the tensor products of the Pauli operators

**Course Outcome 2 (CO2): Relate the postulates of quantum mechanics for computation and illustrate/ demonstrate quantum measurement (K2)**

1. State and explain the postulates of Quantum Mechanics applied to computing.
2. Show the Bloch sphere representation of quantum bits.
3. Find the various states of a given system using state space analysis.
4. Demonstrate the state space representation of composite systems using tensor product.

**Course Outcome 3 (CO3): Identify quantum gates and build quantum circuit model in which most of the quantum algorithms are designed (K3)**

1. Model universal gates using standard quantum gates.
2. Illustrate the implementation of quantum operation using quantum gates.
3. Construct and prove circuit identities.
4. Construct a circuit for implementing controlled U operations
5. Design quantum circuits that implements projective measurement in the computational basis.

**Course Outcome 4 (CO4): Analyse and design quantum algorithms and grasp the advantage they offer over classical counterparts (K4)**

1. Design a circuit that implements Quantum Fourier Transform(QFT) for an n-bit input.
2. Construct the phase estimation algorithm from basic principles and design the circuit for phase estimation using QFT.
3. Interpret phase estimation algorithm for the implementation of order finding and factorisation algorithms.

**SYLLABUS**

**Module 1: Basics of Linear Algebra**

History and Overview of Quantum Computation and Quantum Information, Linear Algebra Basics, Linear Operators and matrices, The Pauli matrices, Inner Products, Eigen values and Eigen vectors, Hermitian operators and Adjoints, Spectral theorem, Tensor Products.

**Module 2: Basics of Quantum Mechanics**

State Space Representation - Bloch Sphere, State Evolution – Unitary transformation, Quantum measurement – Projective measurements, Composite systems - Superposition.

**Module 3: Quantum Gates and Circuits**

Quantum gates – Hadamard gate, NOT gate, controlled-NOT gate, Toffoli gate, Realisation of classical gates with quantum gates – Z Gate, Fredkin Gate, Pauli Matrices – Controlled Swap and Controlled U-operations, Circuit Identities

**Module 4: Quantum Measurement**

Basic principle of quantum measurement - Principle of deferred measurement, Principle of implicit measurement, Gates with projective measurements, Universal quantum gates, Universality of two level unitary gates.

**Module 5: Algorithms**

Quantum Fourier Transform (QFT) – Quantum circuit for QFT, Quantum phase estimation, Modular exponentiation, Order finding and factorisation – Deutsch’s algorithm.

**Text Books**

1. M. A. Nielsen and I. L. Chuang, Quantum Computation and Quantum Information, Cambridge, UK, Cambridge University Press, 2010.
2. J. Gruska, Quantum Computing, McGraw Hill, 1999.
3. G. Strang, Linear algebra and its applications (4th Edition), Thomson, 2006.

**Reference Books**

1. P. Kaye, R. Laflamme, and M. Mosca. An Introduction to Quantum Computing. Oxford, 2007.
2. Eleanor G. Rieffel, Wolfgang H. Polak, “Quantum Computing: A Gentle Introduction,” MIT Press, 2011.
3. Noson Yanofsky and Mirco Mannucci, “Quantum Computing for Computer Scientists”, Cambridge University Press, 2008.
4. Abhijith, J., Adedoyin, Adetokunbo, Ambrosiano, John (and 30 others), “Quantum Algorithm Implementations for Beginners”, [arXiv:1804.03719](https://arxiv.org/abs/1804.03719), 2020.

**Course Contents and Lecture Schedule**

No	Topic	No. of Lectures
<b>1</b>	<b>Basics of Linear Algebra</b>	
1.1	History and Overview of Quantum Computation and Quantum Information	1
1.2	Linear Algebra Basics	1
1.3	Linear Operators and matrices	1
1.4	Pauli matrices	1
1.5	Inner Products, Eigen values and Eigen vectors	1
1.6	Hermitian operators and Adjoints, Spectral theorem	2
1.7	Tensor Products	2
<b>2</b>	<b>Basics of Quantum Mechanics</b>	
2.1	State Space Representation - Bloch Sphere	1
2.2	State Evolution – Unitary transformation	2
2.3	Quantum measurement – Projective measurements	2
2.4	Composite systems - Superposition	2
<b>3</b>	<b>Quantum Gates and Circuits</b>	
3.1	Quantum gates – Hadamard gate, NOT gate, controlled-NOT gate, Toffoli gate	2
3.2	Realisation of classical gates with quantum gates – Z Gate, Fredkin Gate	2
3.3	Pauli Matrices – Controlled Swap and Controlled U-operations	2
3.4	Circuit Identities	1
<b>4</b>	<b>Quantum Measurement</b>	
4.1	Basic principle of quantum measurement - Principle of deferred measurement, Principle of implicit measurement	1
4.2	Gates with projective measurements	2
4.3	Universal quantum gates	1

4.4	Universality of two level unitary gates	2
<b>5</b>	<b>Algorithms</b>	
5.1	Quantum Fourier Transform (QFT)	1
5.2	Quantum circuit for QFT Quantum phase estimation	2
5.3	Modular exponentiation	1
5.4	Order finding and factorisation – Deutsch's algorithm	2

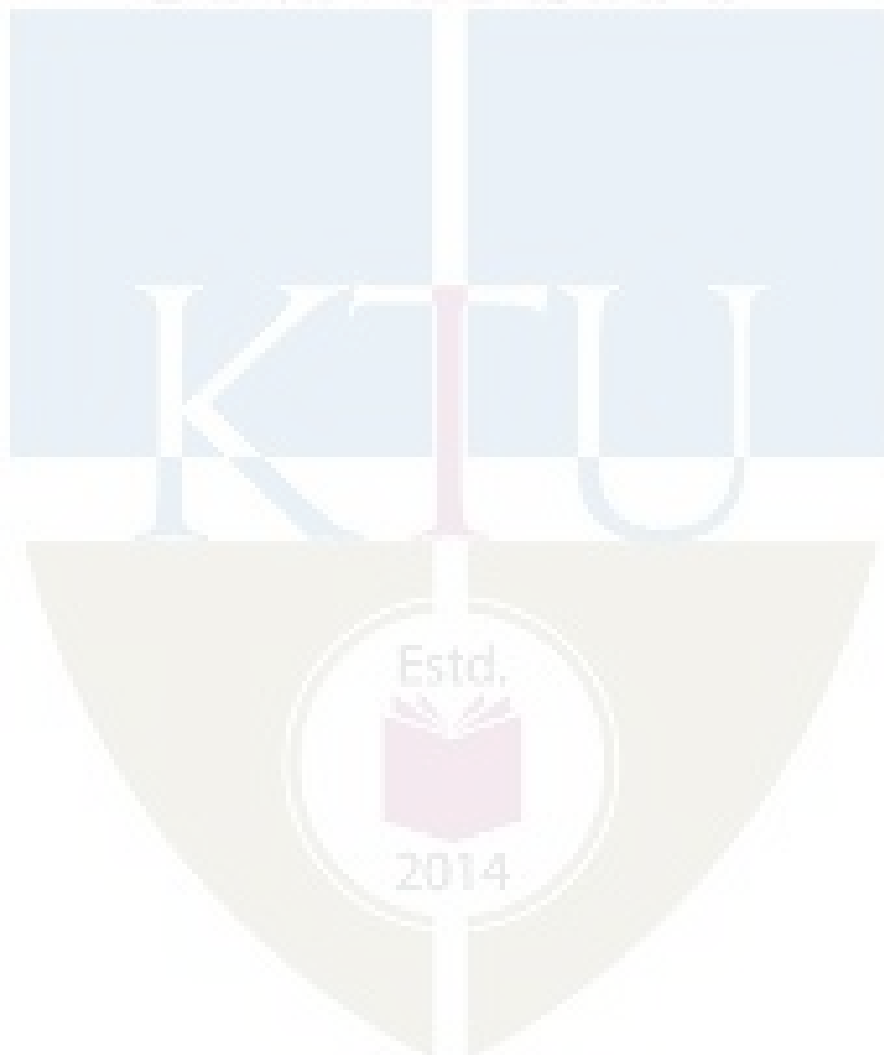

APJ ABDUL KALAM TECHNOLOGICAL UNIVERSITY

SIXTH SEMESTER B.TECH DEGREE EXAMINATION, (Model Question Paper)

Course Code: ECT372

Course Name: QUANTUM COMPUTING

Max. Marks: 100

Duration: 3 Hours

PART A

Answer ALL Questions. Each Carries 3 mark.

- 1 Consider the operator from  $\mathbb{C}^2 \rightarrow \mathbb{C}^2$  given by  $T(x,y) = (ix, iy)$ , where  $Z^2 = -1$ . Find the matrix representation of the Transformation. K2
- 2 Write the Eigen values and Eigen vectors of the matrix  $\begin{bmatrix} 2 & 1 \\ 1 & 2 \end{bmatrix}$ . Is this operator Hermitian? K1
- 3 Write down the Bloch sphere representation of the Quantum bit  $\frac{1}{2}|0\rangle + \frac{j}{\sqrt{2}}|1\rangle$ . K1
- 4 Suppose the first bit of a two bit Quantum System whose state given by  $\alpha|00\rangle + \beta|01\rangle + \chi|10\rangle + \delta|11\rangle$  is measured
  - a. What is the probability that the first bit is observed to be 0?
  - b. Suppose that the first bit is observed to be 0, then what is the resultant state of the system?K3
5. Compute the resultant state of the given circuit for input state  $|00\rangle$ . K3

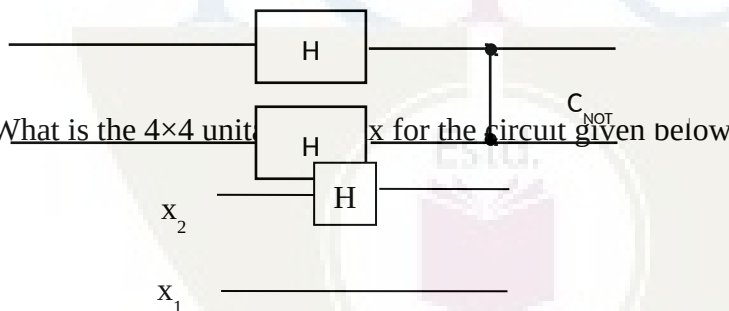

- 6 What is the  $4 \times 4$  unitary matrix  $U$  for the circuit given below K2
- 7 State the two basic principles of quantum measurement and explain it's uses. K1
- 8 For the given circuit, 0 was observed by measuring the second bit. What is the resultant Quantum State of the first bit? K3

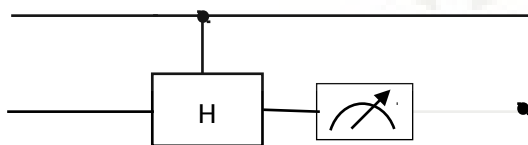

- 9 Give a decomposition of the controlled-Rk gate into single qubit and  $C_{NOT}$  gates. K2
- 10 Draw the 3 input Quantum Fourier Transform (QFT) circuit. K2

Answer one question from each module; each question carries 14 marks.

**Module - I**

- 11 a. Find the eigenvectors and eigenvalues of the following four matrices: 7

$$\sigma_0 = \begin{bmatrix} 1 & 0 \\ 0 & 1 \end{bmatrix} \quad \sigma_1 = \begin{bmatrix} 0 & 1 \\ 1 & 0 \end{bmatrix} \quad \sigma_2 = \begin{bmatrix} 0 & -i \\ i & 0 \end{bmatrix} \quad \sigma_3 = \begin{bmatrix} 1 & 0 \\ 0 & -1 \end{bmatrix}$$

CO1

K2

- b. Give the eigenvalues and eigenvectors of this matrix 7

$$\begin{bmatrix} 1 & 0 & 0 & 0 \\ 0 & 0 & 1 & 0 \\ 0 & 1 & 0 & 0 \\ 0 & 0 & 0 & 1 \end{bmatrix}$$

CO1

K3

**OR**

- 12 a. A matrix M is Hermitian if  $M^\dagger = M$ . Let M be Hermitian. 7

i. Prove that all of its eigenvalues are real. CO1

ii. Prove that  $v^\dagger M v$  is real, for all vectors v. When  $v^\dagger M v > 0$ , we say that  $M > 0$ . K3

- b. Let M be Hermitian, and define 7

$$U = e^{iM} = \sum_k \frac{(iM)^k}{k!}$$

CO1

Prove that  $U^\dagger U = I$ , where I is the identity matrix. For matrix M, let  $M^\dagger = (M^T)^*$ , where  $M^T$  is the transpose of M, and \* denotes the complex conjugate of M. K3

**Module - II**

- 13 a. What is a Quantum State. Explain with examples 2

CO2

K2

- b. Consider the following two-qubit quantum state,  $|\varphi\rangle$ . 12

$$\frac{\sqrt{2}}{3\sqrt{3}}|00\rangle - \frac{1}{\sqrt{6}}|01\rangle + \frac{2i\sqrt{2}}{3\sqrt{3}}|10\rangle + \frac{5i}{3\sqrt{6}}|11\rangle$$

i. What are the probabilities of outcomes 0 and 1 if the first qubit of  $|\varphi\rangle$  is measured? CO2

ii. What are the probabilities of outcomes 0 and 1 if the second qubit of  $|\varphi\rangle$  is measured? K3

iii. What is the state of the system after the first qubit of  $|\varphi\rangle$  is measured to be a 0?

iv. What is the state of the system if the second qubit of  $|\varphi\rangle$  is measured to be a 1?

v. What are the probabilities of outcomes 0 and 1 if the second qubit of the system is measured, after the first qubit of  $|\varphi\rangle$  has been measured to be 0?

vi. What are the probabilities of outcomes 0 and 1 if the first qubit of the system is measured, after the second qubit of  $|\varphi\rangle$  has been measured to be 1?

14 a. State and explain the four postulates of Quantum Mechanics applied to computing. 8  
CO2

b. Which quantum state do we get if we apply  $(H \otimes I)$  CNOT to  

$$\sqrt{\frac{1}{3}}|00\rangle + \sqrt{\frac{2}{3}}|11\rangle$$
 6  
CO2

Here I is the 1-qubit identity operation, H is the 1-qubit Hadamard, and CNOT is the 2-qubit controlled-not operation with the first (=leftmost) qubit being the control. K3

What is the probability of seeing  $|11\rangle$  if we measure the resulting state in the computational basis?

**Module - III**

15 a. Show that  $XYX = -Y$  and use this to prove that  $X R_y(\theta) X = R_y(-\theta)$ . 7  
CO3

b. An arbitrary single qubit unitary operator can be written in the form 7  
 $U = \exp(i\alpha) R_{\hat{n}}(\theta)$ . for some real numbers  $\alpha$  and  $\theta$ , and a real three-dimensional unit vector  $\hat{n}$ . CO3  
K3

- i. Prove this fact.
- ii. Find values for  $\alpha$ ,  $\theta$ , and  $\hat{n}$  giving the Hadamard gate H.
- iii. Find values for  $\alpha$ ,  $\theta$ , and  $\hat{n}$  giving the phase gate.

**OR**

16 a. It is useful to be able to simplify circuits by inspection, using well-known identities. 7  
Prove the following three identities:

- i.  $HXH = Z$  CO3
- ii.  $HYH = -Y$  K3
- iii.  $HZH = X$

b. Show that 7  
CO3  
K3

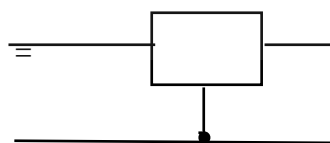
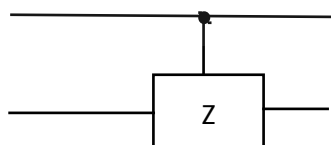



**Module - IV**

- 17 Suppose we have a single qubit operator  $U$  with eigenvalues  $\pm 1$ , so that  $U$  is both Hermitian and unitary. Suppose we wish to measure the observable  $U$ . How can this be implemented by a quantum circuit? Show that the following circuit implements a measurement of  $U$ . 14  
CO3  
K3

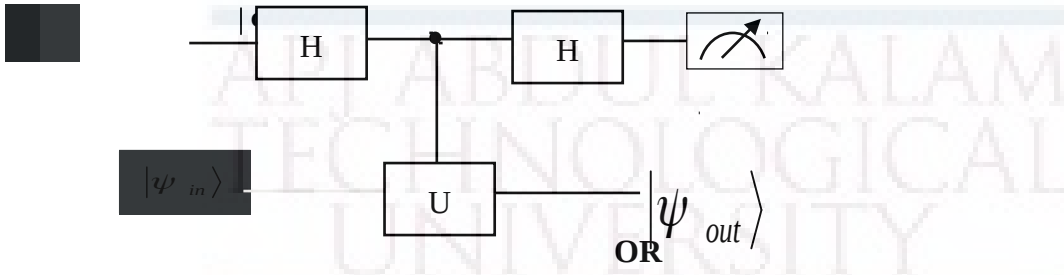

- 18 a. Derive the circuit implementing the controlled- $U$  operation for an arbitrary single qubit  $U$ , using only single qubit operations and the CNOT gate. 7  
CO3  
K4
- b. Using just CNOTs and Toffoli gates, construct a quantum circuit to perform the transformation given below. 7  
CO3

$$\begin{bmatrix} 1 & 0 & 0 & 0 & 0 & 0 & 0 & 0 \\ 0 & 0 & 0 & 0 & 0 & 0 & 0 & 1 \\ 0 & 1 & 0 & 0 & 0 & 0 & 0 & 0 \\ 0 & 0 & 1 & 0 & 0 & 0 & 0 & 0 \\ 0 & 0 & 0 & 1 & 0 & 0 & 0 & 0 \\ 0 & 0 & 0 & 0 & 1 & 0 & 0 & 0 \\ 0 & 0 & 0 & 0 & 0 & 1 & 0 & 0 \\ 0 & 0 & 0 & 0 & 0 & 0 & 1 & 0 \end{bmatrix}$$

K4

**Module - V**

- 19 a. Derive the circuitry for computing a 4-input Quantum Fourier Transform (QFT). 7  
CO4  
K3
- b. The two qubit Quantum Fourier Transform is given by the following matrix. 7  
CO4  
K3

$$F_2 = \frac{1}{2} \begin{bmatrix} 1 & 1 & 1 & 1 \\ 1 & i & -1 & -i \\ 1 & -1 & 1 & -1 \\ 1 & -i & -1 & i \end{bmatrix}$$

Sketch a circuit for implementing the operator  $F_2$  using any combination of 1-qubit Hadamard gates; 1-qubit Pauli gates; 2-qubit CNOT gates and controlled phase shifts. Briefly explain your circuit.

- 20 a. Explain the phase estimation algorithm using Quantum Fourier Transform (QFT). 8  
Derive the circuitry for the Quantum Phase estimation. CO4  
K3
- b. Apply Quantum phase estimation to estimate the phase of a T-Gate. 6  
CO4  
K4

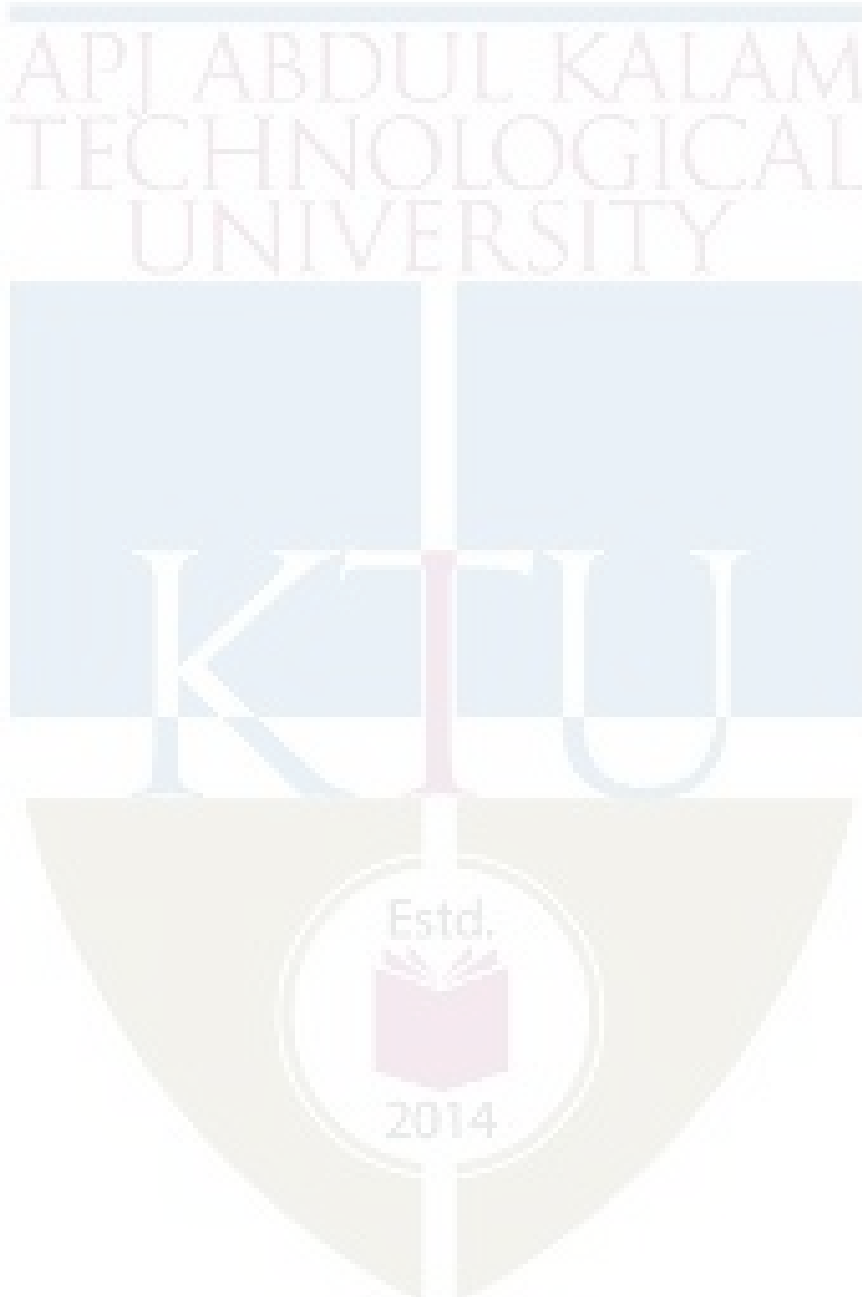

<b>HUT 300</b>	<b>Industrial Economics &amp; Foreign Trade</b>	<b>Category</b>	<b>L</b>	<b>T</b>	<b>P</b>	<b>CREDIT</b>
		HSMC	<b>3</b>	<b>0</b>	<b>0</b>	<b>3</b>

**Preamble:** To equip the students to take industrial decisions and to create awareness of economic environment.

**Prerequisite:** Nil

**Course Outcomes:** After the completion of the course the student will be able to

<b>CO1</b>	Explain the problem of scarcity of resources and consumer behaviour, and to evaluate the impact of government policies on the general economic welfare. (Cognitive knowledge level: <b>Understand</b> )
<b>CO2</b>	Take appropriate decisions regarding volume of output and to evaluate the social cost of production. (Cognitive knowledge level: <b>Apply</b> )
<b>CO3</b>	Determine the functional requirement of a firm under various competitive conditions. (Cognitive knowledge level: <b>Analyse</b> )
<b>CO4</b>	Examine the overall performance of the economy, and the regulation of economic fluctuations and its impact on various sections in the society. (Cognitive knowledge level: <b>Analyse</b> )
<b>CO5</b>	Determine the impact of changes in global economic policies on the business opportunities of a firm. (Cognitive knowledge level: <b>Analyse</b> )

**Mapping of course outcomes with program outcomes**

	<b>PO1</b>	<b>PO2</b>	<b>PO3</b>	<b>PO4</b>	<b>PO5</b>	<b>PO6</b>	<b>PO7</b>	<b>PO8</b>	<b>PO9</b>	<b>PO10</b>	<b>PO11</b>	<b>PO12</b>
<b>CO1</b>	2										3	
<b>CO2</b>	2	2			2	2	3				3	
<b>CO3</b>	2	2	1								3	
<b>CO4</b>	2	2	1			1					3	
<b>CO5</b>	2	2	1								3	

<b>Abstract POs defined by National Board of Accreditation</b>			
<b>PO#</b>	<b>Broad PO</b>	<b>PO#</b>	<b>Broad PO</b>
PO1	Engineering Knowledge	PO7	Environment and Sustainability
PO2	Problem Analysis	PO8	Ethics
PO3	Design/Development of solutions	PO9	Individual and team work
PO4	Conduct investigations of complex problems	PO10	Communication
PO5	Modern tool usage	PO11	Project Management and Finance
PO6	The Engineer and Society	PO12	Lifelong learning

### Assessment Pattern

<b>Bloom's Category</b>	<b>Continuous Assessment Tests</b>		<b>End Semester Examination Marks</b>
	<b>Test 1 (Marks)</b>	<b>Test 2 (Marks)</b>	
Remember	<b>15</b>	<b>15</b>	<b>30</b>
Understand	<b>20</b>	<b>20</b>	<b>40</b>
Apply	<b>15</b>	<b>15</b>	<b>30</b>

### Mark Distribution

<b>Total Marks</b>	<b>CIE Marks</b>	<b>ESE Marks</b>	<b>ESE Duration</b>
<b>150</b>	<b>50</b>	<b>100</b>	<b>3 hours</b>

**Continuous Internal Evaluation Pattern:**

Attendance	: 10 marks
Continuous Assessment - Test (2 numbers)	: 25 marks
Continuous Assessment - Assignment	: 15 marks

**Internal Examination Pattern:**

Each of the two internal examinations has to be conducted out of 50 marks. First series test shall be preferably conducted after completing the first half of the syllabus and the second series test shall be preferably conducted after completing remaining part of the syllabus. There will be two parts: Part A and Part B. Part A contains 5 questions (preferably, 2 questions each from the completed modules and 1 question from the partly completed module), having 3 marks for each question adding up to 15 marks for part A. Students should answer all questions from Part A. Part B contains 7 questions (preferably, 3 questions each from the completed modules and 1 question from the partly completed module), each with 7 marks. Out of the 7 questions, a student should answer any 5.

**End Semester Examination Pattern:**

There will be two parts; Part A and Part B.

Part A	: 30 marks
Part B	: 70 marks

Part A contains 10 questions with 2 questions from each module, having 3 marks for each question. Students should answer all questions. Part B contains 2 questions from each module of which a student should answer any one. Each question can have maximum 3 sub-divisions and carries 14 marks.

# SYLLABUS

## HUT 300 Industrial Economics & Foreign Trade

### Module 1 (Basic Concepts and Demand and Supply Analysis)

Scarcity and choice - Basic economic problems- PPC – Firms and its objectives – types of firms – Utility – Law of diminishing marginal utility – Demand and its determinants – law of demand – elasticity of demand – measurement of elasticity and its applications – Supply, law of supply and determinants of supply – Equilibrium – Changes in demand and supply and its effects – Consumer surplus and producer surplus (Concepts) – Taxation and deadweight loss.

### Module 2 (Production and cost)

Production function – law of variable proportion – economies of scale – internal and external economies – Isoquants, isocost line and producer's equilibrium – Expansion path – Technical progress and its implications – Cobb-Douglas production function - Cost concepts – Social cost: private cost and external cost – Explicit and implicit cost – sunk cost - Short run cost curves - long run cost curves – Revenue (concepts) – Shutdown point – Break-even point.

### Module 3 (Market Structure)

Perfect and imperfect competition – monopoly, regulation of monopoly, monopolistic completion (features and equilibrium of a firm) – oligopoly – Kinked demand curve – Collusive oligopoly (meaning) – Non-price competition – Product pricing – Cost plus pricing – Target return pricing – Penetration pricing – Predatory pricing – Going rate pricing – Price skimming.

### Module 4 (Macroeconomic concepts)

Circular flow of economic activities – Stock and flow – Final goods and intermediate goods - Gross Domestic Product - National Income – Three sectors of an economy- Methods of measuring national income – Inflation- causes and effects – Measures to control inflation- Monetary and fiscal policies – Business financing- Bonds and shares -Money market and Capital market – Stock market – Demat account and Trading account - SENSEX and NIFTY.

### Module 5 (International Trade)

Advantages and disadvantages of international trade - Absolute and Comparative advantage theory - Heckscher - Ohlin theory - Balance of payments – Components – Balance of Payments

deficit and devaluation – Trade policy – Free trade versus protection – Tariff and non-tariff barriers.

### **Reference Materials**

1. Gregory N Mankiw, 'Principles of Micro Economics', Cengage Publications
2. Gregory N Mankiw, 'Principles of Macro Economics', Cengage Publications
3. Dwivedi D N, 'Macro Economics', Tata McGraw Hill, New Delhi.
4. Mithani D M, 'Managerial Economics', Himalaya Publishing House, Mumbai.
5. Francis Cherunilam, 'International Economics', McGraw Hill, New Delhi.

### **Sample Course Level Assessment Questions**

#### **Course Outcome 1 (CO1):**

1. Why does the problem of choice arise?
2. What are the central problems?
3. How do we solve the basic economic problems?
4. What is the relation between price and demand?
5. Explain deadweight loss due to the imposition of a tax.

#### **Course Outcome 2 (CO2):**

1. What is shutdown point?
2. What do you mean by producer equilibrium?
3. Explain break-even point;
4. Suppose a chemical factory is functioning in a residential area. What are the external costs?

#### **Course Outcome 3 (CO3):**

1. Explain the equilibrium of a firm under monopolistic competition.
2. Why is a monopolist called price maker?
3. What are the methods of non-price competition under oligopoly?

4. What is collusive oligopoly?

**Course Outcome 4 (CO4):**

1. What is the significance of national income estimation?
2. How is GDP estimated?
3. What are the measures to control inflation?
4. How does inflation affect fixed income group and wage earners?

**Course Outcome 5 (CO5):**

1. What is devaluation?
2. Suppose a foreign country imposes a tariff on Indian goods. How does it affect India's exports?
3. What is free trade?
4. What are the arguments in favour of protection?



**Model Question paper**

**QP CODE:**

**PAGES:3**

**Reg No:** \_\_\_\_\_

**Name :** \_\_\_\_\_

**APJ ABDUL KALAM TECHNOLOGICAL UNIVERSITY FIFTH /SIXTH SEMESTER  
B.TECH DEGREE EXAMINATION, MONTH & YEAR**

**Course Code: HUT 300**

**Course Name: Industrial Economics & Foreign Trade**

**Max.Marks:100**

**Duration: 3 Hours**

**PART A**

**Answer all Questions. Each question carries 3 Marks**

1. Why does an economic problem arise?
2. What should be the percentage change in price of a product if the sale is to be increased by 50 percent and its price elasticity of demand is 2?
3. In the production function  $Q = 2L^{1/2}K^{1/2}$  if  $L=36$  how many units of capital are needed to produce 60 units of output?
4. Suppose in the short run  $AVC < P < AC$ . Will this firm produce or shut down? Give reason.
5. What is predatory pricing?
6. What do you mean by non- price competition under oligopoly?
7. What are the important economic activities under primary sector?
8. Distinguish between a bond and share?
9. What are the major components of balance of payments?

10. What is devaluation?

(10 x 3 = 30 marks)

### **PART B**

**(Answer one full question from each module, each question carries 14 marks)**

#### **MODULE I**

11. a) Prepare a utility schedule showing units of consumption, total utility and marginal utility, and explain the law of diminishing marginal utility. Point out any three limitations of the law.
- b) How is elasticity of demand measured according to the percentage method? How is the measurement of elasticity of demand useful for the government?

**Or**

12. a) Explain the concepts consumer surplus and producer surplus.
- b) Suppose the government imposes a tax on a commodity where the tax burden met by the consumers. Draw a diagram and explain dead weight loss. Mark consumer surplus, producer surplus, tax revenue and dead weight loss in the diagram.

#### **MODULE II**

13. a) What are the advantages of large-scale production?
- b) Explain Producer equilibrium with the help of isoquants and isocost line. What is expansion path?

**Or**

14. a) Explain break-even analysis with the help of a diagram.
- b) Suppose the monthly fixed cost of a firm is Rs. 40000 and its monthly total variable cost is Rs. 60000.
- If the monthly sales is Rs. 120000 estimate contribution and break-even sales.
  - If the firm wants to get a monthly profit of Rs.40000, what should be the sales?
- c) The total cost function of a firm is given as  $TC=100+50Q - 11Q^2+Q^3$ . Find marginal cost when output equals 5 units.

#### **MODULE III**

15. a) What are the features of monopolistic competition?  
b) Explain the equilibrium of a firm earning supernormal profit under monopolistic competition.

**Or**

16. a) Make comparison between perfect competition and monopoly.  
b) Explain price rigidity under oligopoly with the help of a kinked demand curve.

#### **MODULE IV**

17. a) How is national income estimated under product method and expenditure method?  
b) Estimate GDPmp, GNPmp and National income

Private consumption expenditure	= 2000 (in 000 cores)
Government Consumption	= 500
NFIA	= -(300)
Investment	= 800
Net=exports	=700
Depreciation	= 400
Net-indirect tax	= 300

**Or**

18. a) What are the monetary and fiscal policy measures to control inflation?  
b) What is SENSEX?

#### **MODULE V**

19. a) What are the advantages of disadvantages of foreign trade?  
b) Explain the comparative cost advantage.

**Or**

20. a) What are the arguments in favour protection?  
b) Examine the tariff and non-tariff barriers to international trade.

**(5 × 14 = 70 marks)**

### Teaching Plan

<b>Module 1 (Basic concepts and Demand and Supply Analysis)</b>		<b>7 Hours</b>
1.1	Scarcity and choice – Basic economic problems - PPC	1 Hour
1.2	Firms and its objectives – types of firms	1 Hour
1.3	Utility – Law of diminishing marginal utility – Demand – law of demand	1 Hour
1.4	Measurement of elasticity and its applications	1 Hour
1.5	Supply, law of supply and determinants of supply	1 Hour
1.6	Equilibrium – changes in demand and supply and its effects	1 Hour
1.7	Consumer surplus and producer surplus (Concepts) – Taxation and deadweight loss.	1 Hour
<b>Module 2 (Production and cost)</b>		<b>7 Hours</b>
2.1	Productions function – law of variable proportion	1 Hour
2.2	Economies of scale – internal and external economies	1 Hour
2.3	producers equilibrium – Expansion path	1 Hour
2.4	Technical progress and its implications – cob Douglas Production function	1 Hour
2.5	Cost concepts – social cost: private cost and external cost – Explicit and implicit cost – sunk cost	1 Hour
2.6	Short run cost curves & Long run cost curves	1 Hour
2.7	Revenue (concepts) – shutdown point – Break-even point.	1 Hour
<b>Module 3 (Market Structure)</b>		<b>6 hours</b>
3.1	Equilibrium of a firm, MC – MR approach and TC – TR approach	1 Hour
3.2	Perfect competition & Imperfect competition	1 Hour
3.3	Monopoly – Regulation of monopoly – Monopolistic competition	1 Hour
3.4	Oligopoly – kinked demand curve	1 Hour
3.5	Collusive oligopoly (meaning) – Non price competition	1 Hour
3.6	Cost plus pricing – Target return pricing – Penetration, Predatory pricing – Going rate pricing – price skimming	1 Hour

<b>Module 4 (Macroeconomic concepts)</b>		<b>7 Hours</b>
4.1	Circular flow of economic activities	1 Hour
4.2	Stock and flow – Final goods and intermediate goods – Gross Domestic Product - National income – Three sectors of an economy	1 Hour
4.3	Methods of measuring national income	1 Hour
4.4	Inflation – Demand pull and cost push – Causes and effects	1 Hour
4.5	Measures to control inflation – Monetary and fiscal policies	1 Hour
4.6	Business financing – Bonds and shares – Money market and capital market	1 Hour
4.7	Stock market – Demat account and Trading account – SENSEX and NIFTY	1 Hour
<b>Module 5 (International Trade)</b>		<b>8 Hours</b>
5.1	Advantages and disadvantages of international trade	1 Hour
5.2	Absolute and comparative advantage theory	2 Hour
5.3	Heckscher – Ohlin theory	1 Hour
5.4	Balance of payments - components	1 Hour
5.5	Balance of payments deficit and devaluation	1 Hour
5.6	Trade policy – Free trade versus protection	1 Hour
5.7	Tariff and non tariff barriers.	1 Hour

<b>HUT 310</b>	<b>Management for Engineers</b>	<b>Category</b>	<b>L</b>	<b>T</b>	<b>P</b>	<b>Credit</b>
		<b>HMC</b>	<b>3</b>	<b>0</b>	<b>0</b>	<b>3</b>

**Preamble:** This course is intended to help the students to learn the basic concepts and functions of management and its role in the performance of an organization and to understand various decision-making approaches available for managers to achieve excellence. Learners shall have a broad view of different functional areas of management like operations, human resource, finance and marketing.

**Prerequisite:** Nil

**Course Outcomes** After the completion of the course the student will be able to

<b>CO1</b>	Explain the characteristics of management in the contemporary context (Cognitive Knowledge level: <b>Understand</b> ).
<b>CO2</b>	Describe the functions of management (Cognitive Knowledge level: <b>Understand</b> ).
<b>CO3</b>	Demonstrate ability in decision making process and productivity analysis (Cognitive Knowledge level: <b>Understand</b> ).
<b>CO4</b>	Illustrate project management technique and develop a project schedule (Cognitive Knowledge level: <b>Apply</b> ).
<b>CO5</b>	Summarize the functional areas of management (Cognitive Knowledge level: <b>Understand</b> ).
<b>CO6</b>	Comprehend the concept of entrepreneurship and create business plans (Cognitive Knowledge level: <b>Understand</b> ).

### Mapping of course outcomes with program outcomes

	PO1	PO2	PO3	PO4	PO5	PO6	PO7	PO8	PO9	PO10	PO11	PO12
CO1	2				1	2	2	2		2	1	1
CO2	2				1	1		2	1	2	1	1
CO3	2	2	2	2	1							
CO4	2	2	2	2	1						2	1
CO5	2					1	1		1	2	1	
CO6		2	2	2	1	1	1	1	1	1	1	1

Abstract POs defined by National Board of Accreditation				
PO1	Engineering Knowledge		PO7	Environment and Sustainability
PO2	Problem Analysis		PO8	Ethics
PO3	Design/Development of solutions		PO9	Individual and team work
PO4	Conduct investigations of complex problems		PO10	Communication
PO5	Modern tool usage		PO11	Project Management and Finance
PO6	The Engineer and Society		PO12	Life long learning

### Assessment Pattern

Bloom's Category	Test 1 (Marks in percentage)	Test 2 (Marks in percentage)	End Semester Examination (Marks in percentage)
Remember	15	15	30
Understand	15	15	30
Apply	20	20	40
Analyse			
Evaluate			
Create			

## Mark Distribution

Total Marks	CIE Marks	ESE Marks	ESE Duration
150	50	100	3 Hours

### Continuous Internal Evaluation Pattern:

Attendance : 10 marks

Continuous Assessment - Test : 25 marks

Continuous Assessment - Assignment : 15 marks

### Internal Examination Pattern:

Each of the two internal examinations has to be conducted out of 50 marks. First series test shall be preferably conducted after completing the first half of the syllabus and the second series test shall be preferably conducted after completing remaining part of the syllabus. There will be two parts: Part A and Part B. Part A contains 5 questions (preferably, 2 questions each from the completed modules and 1 question from the partly completed module), having 3 marks for each question adding up to 15 marks for part A. Students should answer all questions from Part A. Part B contains 7 questions (preferably, 3 questions each from the completed modules and 1 question from the partly completed module), each with 7 marks. Out of the 7 questions, a student should answer any 5.

### End Semester Examination Pattern:

There will be two parts; Part A and Part B. Part A contains 10 questions with 2 questions from each module, having 3 marks for each question. Students should answer all questions. Part B contains 2 questions from each module of which a student should answer any one. Each question can have maximum 2 sub-divisions and carries 14 marks.



## **SYLLABUS**

### **HUT 310 Management for Engineers (35 hrs)**

#### **Module 1 (Introduction to management Theory- 7 Hours)**

Introduction to management theory, Management Defined, Characteristic of Management, Management as an art-profession, System approaches to Management, Task and Responsibilities of a professional Manager, Levels of Manager and Skill required.

#### **Module 2 (management and organization- 5 hours)**

Management Process, Planning types , Mission, Goals, Strategy, Programmes, Procedures, Organising, Principles of Organisation, Delegation, Span of Control, Organisation Structures, Directing, Leadership, Motivation, Controlling..

#### **Module 3 (productivity and decision making- 7 hours)**

Concept of productivity and its measurement; Competitiveness; Decision making process; decision making under certainty, risk and uncertainty; Decision trees; Models of decision making.

#### **. Module 4 (project management- 8 hours)**

Project Management, Network construction, Arrow diagram, Redundancy. CPM and PERT Networks, Scheduling computations, PERT time estimates, Probability of completion of project, Introduction to crashing.

#### **Module 5 (functional areas of management- 8 hours)**

Introduction to functional areas of management, Operations management, Human resources management, Marketing management, Financial management, Entrepreneurship, Business plans, Corporate social responsibility, Patents and Intellectual property rights.

#### **References:**

1. H. Koontz, and H. Weihrich, Essentials of Management: An International Perspective. 8th ed., McGraw-Hill, 2009.
2. P C Tripathi and P N Reddy, Principles of management, TMH, 4<sup>th</sup> edition, 2008.
3. P. Kotler, K. L. Keller, A. Koshy, and M. Jha, Marketing Management: A South Asian Perspective. 14th ed., Pearson, 2012.
4. M. Y. Khan, and P. K. Jain, Financial Management, Tata-McGraw Hill, 2008.
5. R. D. Hisrich, and M. P. Peters, Entrepreneurship: Strategy, Developing, and Managing a New Enterprise, 4th ed., McGraw-Hill Education, 1997.
6. D. J. Sumanth, Productivity Engineering and Management, McGraw-Hill Education, 1985.
7. K.Ashwathappa, 'Human Resources and Personnel Management', TMH, 3<sup>rd</sup> edition, 2005.
8. R. B. Chase, Ravi Shankar and F. R. Jacobs, Operations and Supply Chain Management, 14th ed. McGraw Hill Education (India), 2015.

### **Sample Course Level Assessment Questions**

**Course Outcome1 (CO1):** Explain the systems approach to management?

**Course Outcome 2 (CO2):** Explain the following terms with a suitable example Goal, Objective, and Strategy.

**Course Outcome 3 (CO3):** Mr. Shyam is the author of what promises to be a successful novel. He has the option to either publish the novel himself or through a publisher. The publisher is offering Mr. Shyam Rs. 20,000 for signing the contract. If the novel is successful, it will sell 200,000 copies. Else, it will sell 10,000 copies only. The publisher pays a Re. 1 royalty per copy. A market survey indicates that there is a 70% chance that the novel will be successful. If Mr. Shyam undertakes publishing, he will incur an initial cost of Rs. 90,000 for printing and marketing., but each copy sold will net him Rs. 2. Based on the given information and the

decision analysis method, determine whether Mr. Shyam should accept the publisher's offer or publish the novel himself.

**Course Outcome 4 (CO4):** Explain the concepts of crashing and dummy activity in project management.

**Course Outcome 5 (CO5):** Derive the expression for the Economic order quantity (EOQ)?

**Course Outcome 6 (CO6):** Briefly explain the theories of Entrepreneurial motivation.?

**Model Question Paper**

QP CODE:

PAGES: 4

Reg No: \_\_\_\_\_

Name: \_\_\_\_\_

**APJ ABDUL KALAM TECHNOLOGICAL UNIVERSITY  
FOURTH SEMESTER B.TECH DEGREE EXAMINATION, MONTH & YEAR**

**Course Code: HUT 310**

**Course name: Management for Engineers**

**Max Marks: 100**

**Duration: 3 Hours**

**PART-A (Answer All Questions. Each question carries 3 marks)**

1. "Management is getting things done through other." Elaborate.
2. Comment on the true nature of management. Is it a science or an art?
3. Planning is looking ahead and controlling is looking back. Comment with suitable examples
4. Explain the process of communication?
5. Explain the hierarchy of objectives?
6. Explain the types of decisions?
7. Describe the Economic man model?
8. Explain the concepts of crashing and dummy activity in project management.
9. Differentiate the quantitative and qualitative methods in forecasting.
10. What are the key metrics for sustainability measurement? What makes the measurement and reporting of sustainability challenging?

**PART-B (Answer any one question from each module)**

11. a) Explain the systems approach to management. (10)  
b) Describe the roles of a manager (4)

**OR**

12. a) Explain the 14 principles of administrative management? **(10)**

b) Explain the different managerial skills **(4)**

13. a) What are planning premises, explain the classification of planning premises. **(10)**

b) Distinguish between strategy and policy. How can policies be made effective. **(4)**

**OR**

14 a) Explain three motivational theories. **(9)**

b) Describe the managerial grid. **(5)**

15. a) Modern forest management uses controlled fires to reduce fire hazards and to stimulate new forest growth. Management has the option to postpone or plan a burning. In a specific forest tract, if burning is postponed, a general administrative cost of Rs. 300 is incurred. If a controlled burning is planned, there is a 50% chance that good weather will prevail and burning will cost Rs. 3200. The results of the burning may be either successful with probability 0.6 or marginal with probability 0.4. Successful execution will result in an estimated benefit of Rs. 6000, and marginal execution will provide only Rs. 3000 in benefits. If the weather is poor, burning will be cancelled incurring a cost of Rs. 1200 and no benefit. i) Develop a decision tree for the problem. (ii) Analyse the decision tree and determine the optimal course of action. **(8)**

b) Student tuition at ABC University is \$100 per semester credit hour. The Education department supplements the university revenue by matching student tuition, dollars per dollars. Average class size for typical three credit course is 50 students. Labour costs are \$4000 per class, material costs are \$20 per student, and overhead cost are \$25,000 per class. (a) Determine the total factor productivity. (b) If instructors deliver lecture 14 hours per week and the semester lasts for 16 weeks, what is the labour productivity? **(6)**

**OR**

16. a) An ice-cream retailer buys ice cream at a cost of Rs. 13 per cup and sells it for Rs. 20 per cup; any remaining unsold at the end of the day, can be disposed at a salvage price of Rs. 2.5 per cup. Past sales have ranged between 13 and 17 cups per day; there is no reason to believe that

sales volume will take on any other magnitude in future. Find the expected monetary value and EOL, if the sales history has the following probabilities:  
(9)

<b>Market Size</b>	13	14	15	16	17
<b>Probability</b>	0.10	0.15	0.15	0.25	0.35

b) At Modern Lumber Company, Kishore the president and a producer of an apple crates sold to growers, has been able, with his current equipment, to produce 240 crates per 100 logs. He currently purchases 100 logs per day, and each log required 3 labour hours to process. He believes that he can hire a professional buyer who can buy a better quality log at the same cost. If this is the case, he increases his production to 260 crates per 100 logs. His labour hours will increase by 8 hours per day. What will be the impact on productivity (measured in crates per labour-hour) if the buyer is hired? What is the growth in productivity in this case?  
(5)

17. a) A project has the following list of activities and time estimates:

<b>Activity</b>	<b>Time (Days)</b>	<b>Immediate Predecessors</b>
A	1	-
B	4	A
C	3	A
D	7	A
E	6	B
F	2	C, D
G	7	E, F
H	9	D
I	4	G, H

(a) Draw the network. (b) Show the early start and early finish times. (c) Show the critical path.  
(10)

b) An opinion survey involves designing and printing questionnaires, hiring and training personnel, selecting participants, mailing questionnaires and analysing data. Develop the precedence relationships and construct the project network. **(4)**

**OR**

18. a) The following table shows the precedence requirements, normal and crash times, and normal and crash costs for a construction project:

Activity	Immediate Predecessors	Required Time (Weeks)		Cost (Rs.)	
		Normal	Crash	Normal	Crash
A	-	4	2	10,000	11,000
B	A	3	2	6,000	9,000
C	A	2	1	4,000	6,000
D	B	5	3	14,000	18,000
E	B, C	1	1	9,000	9,000
F	C	3	2	7,000	8,000
G	E, F	4	2	13,000	25,000
H	D, E	4	1	11,000	18,000
I	H, G	6	5	20,000	29,000

Draw the network. (b) Determine the critical path. (c) Determine the optimal duration and the associated cost. **(10)**

b) Differentiate between CPM and PERT. **(4)**

19. a) What is meant by market segmentation and explain the process of market segmentation **(8)**

b) The Honda Co. in India has a division that manufactures two-wheel motorcycles. Its budgeted sales for Model G in 2019 are 80,00,000 units. Honda's target ending inventory is 10,00,000 units and its beginning inventory is 12,00,000 units. The company's budgeted selling price to its distributors and dealers is Rs. 40,000 per motorcycle. Honda procures all its wheels from an

outside supplier. No defective wheels are accepted. Honda's needs for extra wheels for replacement parts are ordered by a separate division of the company. The company's target ending inventory is 3,00,000 wheels and its beginning inventory is 2,00,000 wheels. The budgeted purchase price is Rs. 1,600 per wheel.

(a) Compute the budgeted revenue in rupees.

(b) Compute the number of motorcycles to be produced.

Compute the budgeted purchases of wheels in units and in rupees.? **(6)**

**OR**

20. a) a) "Human Resource Management policies and principles contribute to effectiveness, continuity and stability of the organization". Discuss. (b) What is a budget? Explain how sales budget and production budgets are prepared? **(10)**

b) Distinguish between the following: (a) Assets and Liabilities (b) Production concept and Marketing concept (c) Needs and Wants (d) Design functions and Operational control functions in operations **(4)**



## Teaching Plan

Sl.No	TOPIC	SESSION
<b>Module I</b>		
1.1	Introduction to management	1
1.2	Levels of managers and skill required	2
1.3	Classical management theories	3
1.4	neo-classical management theories	4
1.5	modern management theories	5
1.6	System approaches to Management,	6
1.7	Task and Responsibilities of a professional Manager	7
<b>Module 2</b>		
2.1	Management process – planning	8
2.2	Mission – objectives – goals – strategy – policies – programmes – procedures	9
2.3	Organizing, principles of organizing, organization structures	10
2.4	Directing, Leadership	11
2.5	Motivation, Controlling	12
<b>Module III</b>		
3.1	Concept of productivity and its measurement Competitiveness	13
3.2	Decision making process;	14
3.3	Models in decision making	15
3.4	Decision making under certainty and risk	16
3.5	Decision making under uncertainty	17
3.6	Decision trees	18
3.7	Models of decision making.	19
<b>Module IV</b>		
4.1	Project Management	20

<b>Sl.No</b>	<b>TOPIC</b>	<b>SESSION</b>
	<b>Module I</b>	
4.2	Network construction	21
4.3	Arrow diagram, Redundancy	22
4.4	CPM and PERT Networks	23
4.5	Scheduling computations	24
4.6	PERT time estimates	25
4.7	Probability of completion of project	26
4.8	Introduction to crashing	
	<b>Module V</b>	
5.1	Introduction to functional areas of management,	28
5.2	Operations management	29
5.3	Human resources management ,	30
5.4	Marketing management	31
5.5	Financial management	32
5.6	Entrepreneurship,	33
5.7	Business plans	34
5.8	Corporate social responsibility, Patents and Intellectual property rights	35



**Assessment Pattern**

<b>Bloom's Category</b>	<b>End Semester Examination</b>
Remember	10
Understand	20
Apply	20
Analyse	
Evaluate	
Create	

**Mark distribution**

<b>Total Marks</b>	<b>CIE</b>	<b>ESE</b>	<b>ESE Duration</b>
50	0	50	1 hour

**End Semester Examination Pattern:** Objective Questions with multiple choice (Four). Question paper include Fifty Questions of One mark each covering the five identified courses.

**Syllabus****Full Syllabus of all five selected courses****Course Contents and Lecture Schedule**

No	Topic	No. of Lectures
<b>1</b>	<b>Analog Circuits</b>	
1.1	Mock Test on Module 1 and Module 2	1
1.2	Mock Test on Module 3, Module 4 and Module 5	1
1.3	Feedback and Remedial	1
<b>2</b>	<b>Logic Circuit design</b>	
2.1	Mock Test on Module 1, Module 2 and Module 3	1
2.2	Mock Test on Module 4 and Module 5	1
2.3	Feedback and Remedial	1
<b>3</b>	<b>Linear IC</b>	
3.1	Mock Test on Module 1 and Module 2	1
3.2	Mock Test on Module 3, Module 4 and Module 5	1
3.3	Feedback and Remedial	1
<b>4</b>	<b>Digital Signal Processing</b>	
4.1	Mock Test on Module 1, Module 2 and Module 3	1
4.2	Mock Test on Module 4 and Module 5	1
4.3	Mock Test on Module 1, Module 2 and Module 3	1
<b>5</b>	<b>Analog and Digital Communication</b>	
5.1	Mock Test on Module 1, Module 2 and Module 3	1
5.2	Mock Test on Module 4 and Module 5	1
5.3	Feedback and Remedial	1

ECL332	COMMUNICATION LAB	CATEGORY	L	T	P	CREDIT
		PCC	0	0	3	2

**Preamble:**

- The experiments are categorized into three parts Part A, Part B and Part C.
- The experiments in Part A involves design and setting up of prototype circuits on breadboard or trainer kits.
- The experiments in Part B are software simulations and can be done using GNU Octave or Python. Other softwares such as MATLAB/ SCILAB/ LabVIEW can also be used.
- The experiments in Part C are emulations using SDR (software-designed-radio) dongle connected to laptops. A control software has to be installed on the laptops. A combination of open-source GNU Radio software, RTL-SDR (for reception) and HackRF / LimeSDR (for transmission) can be used to conduct these experiments. Other platforms such as LabView with NI-USRP or Simulink with RTL-SDR can also be used.

**Prerequisites:**

- ECT 305 Analog and Digital Communication
- ECT 303 Digital Signal Processing

**Course Outcomes :**The student will be able to

CO 1	Setup simple prototype circuits for waveform coding and digital modulation techniques working in a team.
CO 2	Simulate the error performance of a digital communication system using standard binary and $M$ -ary modulation schemes.
CO 3	Develop hands-on skills to emulate a communication system with software-designed-radio working in a team.

**Mapping of Course Outcomes with Program Outcomes**

	PO1	PO2	PO3	PO4	PO5	PO6	PO7	PO8	PO9	PO10	PO11	PO12
CO1	3	3	3	2	3	0	0	0	3	2	0	1
CO2	3	3	3	2	3	0	0	0	0	0	0	1
CO3	3	3	3	3	3	0	0	0	3	2	0	3

**Assessment Pattern Mark****Distribution;**

Total Mark	CIE	ESE
150	75	75

**Continuous Internal Evaluation Pattern:**

Attribute	Mark
Attendance	15
Continuous assessment	30
Internal Test (Immediately before the second series test)	30

**End Semester Examination Pattern:** The following guidelines should be followed regarding award of marks.

Attribute	Mark
Preliminary work	15
Implementing the work/Conducting the experiment	10
Performance, result and inference (usage of equipments and trouble shooting)	25
Viva voce	20
Record	5

**General instructions:** End-semester practical examination is to be conducted immediately after the second series test covering entire syllabus given below. Evaluation is to be conducted under the equal responsibility of both the internal and external examiners. The number of candidates evaluated per day should not exceed 20. Students shall be allowed for the examination only on submitting the duly certified record. The external examiner shall endorse the record.

**Experiments****Part A**

Any two experiments are mandatory. The students shall design and setup simple prototype circuits with the help of available ICs. They can observe Waveforms produced by these circuits for standard ideal inputs.

1. FM generation and demodulation using PLL
2. Generation and Detection of PCM signals

3. Generation and Detection of Delta modulated signals
4. Generation and Detection of BPSK
5. Generation and Detection of 16-QPSK

### Part B

All experiments are mandatory. The students shall write scripts to simulate components of communication systems. They shall plot various graphs that help to appreciate and compare performance.

#### 1. Performance of Waveform Coding Using PCM

1. Generate a sinusoidal waveform with a DC offset so that it takes only positive amplitude value.
2. Sample and quantize the signal using an uniform quantizer with number of representation levels  $L$ . Vary  $L$ . Represent each value using decimal to binary encoder.
3. Compute the signal-to-noise ratio in dB.
4. Plot the SNR versus number of bits per symbol. Observe that the SNR increases linearly.

#### 2. Pulse Shaping and Matched Filtering

1. Generate a string of message bits.
2. Use root raised cosine pulse  $p(t)$  as the shaping pulse, and generate the corresponding baseband signal with a fixed bit duration  $T_b$ . You may use roll-off factor as  $\alpha = 0.4$ .
3. Simulate transmission of baseband signal via an AWGN channel
4. Apply matched filter with frequency response  $P_r(f) = P^*(f)$  to the received signal.
5. Sample the signal at  $mT_b$  and compare it against the message sequence.

#### 3. Eye Diagram

1. Generate a string of message bits.
2. Use raised cosine pulse  $p(t)$  as the shaping pulse, and generate the corresponding baseband signal with a fixed bit duration  $T_b$ . You may use roll-off factor as  $\alpha = 0.4$ .
3. Use various roll off factors and plot the eye diagram in each case for the received signal. Make a comparison study among them.

#### 4. Error Performance of BPSK

1. Generate a string of message bits.
2. Encode using BPSK with energy per bit  $E_b$  and represent it using points in a signal-space.
3. Simulate transmission of the BPSK modulated signal via an AWGN channel with variance  $N_0/2$ .
4. Detect using an ML decoder and plot the probability of error as a function of SNR per bit  $E_b/N_0$ .

#### 5. Error Performance of QPSK

1. Generate a string of message bits.
2. Encode using QPSK with energy per symbol  $E_s$  and represent it using points in a signal-space.
3. Simulate transmission of the QPSK modulated signal via an AWGN channel with variance  $N_0/2$  in both  $I$ -channel and  $Q$ -channel.
4. Detect using an ML decoder and plot the probability of error as a function of SNR per bit  $E_b/N_0$  where  $E_s = 2E_b$ .

### Part C

Any two experiments are mandatory. The students shall emulate communication systems with the help of software-defined-radio hardware and necessary control software. Use available blocks in GNU Radio to implement all the signal processing. These experiments will help students to appreciate better how theoretical concepts are translated into practice.

#### 1. Familiarization with Software Defined Radio (Hardware and Control Software)

1. Familiarize with an SDR hardware for reception and transmission of RF signal.
2. Familiarize how it can be interfaced with computer.
3. Familiarize with GNU Radio (or similar software's like Simulink/ Lab-View) that can be used to process the signals received through the SDR hardware.
4. Familiarize available blocks in GNU Radio. Study how signals can be generated and spectrum (or power spectral density) of signals can be analyzed. Study how filtering can be performed.



**2. FM Reception**

1. Receive digitized FM signal (for the clearest channel in the lab) using the SDR board.
2. Set up an LPF and FM receiver using GNU Radio.
3. Use appropriate sink in GNU Radio to display the spectrum of signal.
4. Resample the voice to make it suitable for playing on computer speaker.

**3. FM Transmission**

1. Use a wave file source.
2. Set up an FM transmitter using GNU Radio.
3. Resample the voice source and transmit using the SDR.

**Schedule of Experiments** Every experiment should be completed in three hours.

**Text books and References**

1. Carl Laufer, "The Hobbyist's Guide to the RTL-SDR: Really Cheap Software Defined Radio"
2. Neel Pandeya, "Implementation of a Simple FM Receiver in GNU Radio," <https://kb.ettus.com/>
3. WH Tranter, KS Shanmugan, TS Rappaport, KL Kosbar, "Principles of Communication Systems Simulation with Wireless Applications", Prentice Hall
4. Michael Ossmann, "Software Defined Radio with HackRF," YouTube Tutorial
5. Mathuranathan Viswanathan, "Digital Modulations using Python"

ECD334	MINIPROJECT	CATEGORY	L	T	P	CREDIT
		PWS	0	0	3	2

**Preamble:** The course aims

- To estimate the ability of the students in transforming the theoretical knowledge studied in to a working model of an electronic system
- For enabling the students to gain experience in organisation and implementation of small projects.
- Design and development of Small electronic project based on hardware or a combination of hardware and software for electronics systems.

### Course Plan

In this course, each group consisting of three/four members is expected to design and develop a moderately complex electronic system with practical applications, this should be a working model. The basic concept of product design may be taken into consideration.

Students should identify a topic of interest in consultation with Faculty/Advisor. Review the literature and gather information pertaining to the chosen topic. State the objectives and develop a methodology to achieve the objectives. Carryout the design/fabrication or develop codes/programs to achieve the objectives. Demonstrate the novelty of the project through the results and outputs. The progress of the mini project is evaluated based on a minimum of two reviews.

The review committee may be constituted by the Head of the Department. A project report is required at the end of the semester. The product has to be demonstrated for its full design specifications. Innovative design concepts, reliability considerations, aesthetics/ergonomic aspects taken care of in the project shall be given due weight.

### Course Outcomes

CO1	Be able to practice acquired knowledge within the selected area of technology for project development.
CO2	Identify, discuss and justify the technical aspects and design aspects of the project with a systematic approach.
CO3	Reproduce, improve and refine technical aspects for engineering projects.
CO4	Work as a team in development of technical projects.
CO5	Communicate and report effectively project related activities and findings.

**Mapping of course outcomes with program outcomes**

	PO 1	PO 2	PO 3	PO 4	PO 5	PO 6	PO 7	PO 8	PO 9	PO 10	PO 11	PO 12
CO 1	3	3	3	2		3						2
CO 2	3	3	3	2		3					3	2
CO 3	3	3	3	2		3					3	2
CO 4								3		3	3	2
CO 5								3	3	3		2

**Evaluation**

The internal evaluation will be made based on the product, the report and a viva- voce examination, conducted by a 3-member committee appointed by Head of the Department comprising HoD or a senior faculty member, Academic coordinator for that program, project guide/coordinator.

The Committee will be evaluating the level of completion and demonstration of functionality/specifications, presentation, oral examination, work knowledge and involvement.

**Mark distribution**

Total Marks	CIE	ESE	ESE Duration
150	75	75	1 hour

**Split-up of CIE**

Component	Marks
Attendance	10
Marks awarded based on guide's evaluation	15
Project Report	10
Evaluation by Committee	40

**Split-up of ESE**

Component	Marks
Level of completion	10
Demonstration of functionality	25
Project Report	10
Viva-voce	20
Presentation	10