

**MATHEMATICS – Third Semester B. Tech**

( For all branches except Computer Science and Information Technology)

CODE	COURSE NAME	CATEGORY	L	T	P	CREDIT
MAT201	PARTIAL DIFFERENTIAL EQUATIONS AND COMPLEX ANALYSIS	BASIC SCIENCE COURSE	3	1	0	4

**Preamble:** This course introduces basic ideas of partial differential equations which are widely used in the modelling and analysis of a wide range of physical phenomena and has got application across all branches of engineering. To understand the basic theory of functions of a complex variable, residue integration and conformal transformation.

**Prerequisite:** A basic course in partial differentiation and complex numbers.

**Course Outcomes:** After the completion of the course the student will be able to

CO 1	Understand the concept and the solution of partial differential equation.
CO 2	Analyse and solve one dimensional wave equation and heat equation.
CO 3	Understand complex functions, its continuity differentiability with the use of Cauchy-Riemann equations.
CO 4	Evaluate complex integrals using Cauchy’s integral theorem and Cauchy’s integral formula, understand the series expansion of analytic function
CO 5	Understand the series expansion of complex function about a singularity and Apply residue theorem to compute several kinds of real integrals.

**Mapping of course outcomes with program outcomes**

PO’s	Broad area
PO 1	Engineering Knowledge
PO 2	Problem Analysis
PO 3	Design/Development of solutions
PO 4	Conduct investigations of complex problems
PO 5	Modern tool usage
PO 6	The Engineer and Society
PO 7	Environment and Sustainability
PO 8	Ethics
PO 9	Individual and team work

PO 10	Communication
PO 11	Project Management and Finance
PO 12	Life long learning

**Mapping of course outcomes with program outcomes**

	PO 1	PO 2	PO 3	PO 4	PO 5	PO 6	PO 7	PO 8	PO 9	PO 10	PO 11	PO 12
CO 1	3	3	3	3	2	1				2		2
CO 2	3	3	3	3	2	1				2		2
CO 3	3	3	3	3	2	1				2		2
CO 4	3	3	3	3	2	1				2		2
CO 5	3	3	3	3	2	1				2		2

**Assessment Pattern**

Bloom's Category	Continuous Assessment Tests(%)		End Semester Examination(%)
	1	2	
Remember	10	10	10
Understand	30	30	30
Apply	30	30	30
Analyse	20	20	20
Evaluate	10	10	10
Create			

**End Semester Examination Pattern:** There will be two parts; Part A and Part B. Part A contain 10 questions with 2 questions from each module, having 3 marks for each question. Students should answer all questions. Part B contains 2 questions from each module of which student should answer any one. Each question can have maximum 2 sub-divisions and carry 14 marks.

**Course Level Assessment Questions.**

**Course Outcome 1 (CO1):**

1. Form the partial differential equation given  $z = xf(x) + ye^2$
2. What is the difference between complete integral and singular integral of a partial differential equation
3. Solve  $3z = xp + yq$
4. Solve  $(p^2 + q^2)y = qz$
5. Solve  $u_x - 2u_t = u$  by the method of separation of variables

**Course Outcome 2 (CO2):**

1. Write any three assumptions in deriving one dimensional wave equations
2. Derive one Dimensional heat equation
3. Obtain a general solution for the one dimensional heat equation  $\frac{\partial u}{\partial t} = c^2 \frac{\partial^2 u}{\partial x^2}$
4. A tightly stretched flexible string has its ends fixed at  $x = 0$  and  $x = l$ . At  $t = 0$ , the string is given a shape defined by  $f(x) = \mu x(l - x)$  where  $\mu$  is a constant
5. Find the temperature  $u(x, t)$  in a bar which is perfectly insulated laterally whose ends are kept at  $0^\circ C$  and whose initial temperature (in degree Celsius) is  $f(x) = x(10 - x)$  given that its length is 10 cm and specific heat is 0.056 cal/gram deg

**Course Outcome 3(CO3):**

1. Separate the real and imaginary parts of  $f(z) = \frac{1}{1+z}$
2. Check whether the function  $f(z) = \frac{Re(z^2)}{|z|}$  is continuous at  $z = 0$  given  $f(0) = 0$
3. Determine a and b so that function  $u = e^{-\pi x} \cos y$  is harmonic. Find its harmonic conjugate.
4. Find the fixed points of  $w = \frac{i}{2z-1}$
5. Find the image of  $|z| \leq \frac{1}{2}$ ,  $-\frac{\pi}{8} < \arg z < \frac{\pi}{8}$  under  $w = z^2$

**Course Outcome 4(CO4):**

1. Find the value of  $\int_C \exp(z^2) dz$  where C is  $|z| = 1$
2. Integrate the function  $\int_C \frac{\sin z}{z+4iz} dz$  where C is  $|z - 4 - 2i| = 6.5$
3. Evaluate  $\int_C \frac{e^z}{(z-\frac{\pi}{4})^3} dz$  where C is  $|z| = 1$
4. Find the Maclaurin series expansion of  $f(z) = \frac{i}{1-z}$  and state the region of convergence.
5. Find the image of  $|z| = 2$  under the mapping  $w = z + \frac{1}{z}$

**Course Outcome 5 (CO5):**

1. Determine the singularity of  $\exp\left(\frac{1}{z}\right)$
2. Find the Laurent series of  $\frac{1}{z^2(z-i)}$  about  $z = i$
3. Find the residues of  $f(z) = \frac{50z}{z^3 + 2z^2 - 7z + 4}$
4. Evaluate  $\int_C \tan 2\pi z dz$  where C is  $|z - 0.2| = 0.2$
5. Evaluate  $\int_0^{2\pi} \frac{d\theta}{\sqrt{2-\cos \theta}}$

**Syllabus**

**Module 1 (Partial Differential Equations) (8 hours)**

**(Text 1-Relevant portions of sections 17.1, 17.2, 17.3, 17.4, 17.5, 17.7, 18.1, 18.2)**

Partial differential equations, Formation of partial differential equations –elimination of arbitrary constants-elimination of arbitrary functions, Solutions of a partial differential equations, Equations solvable by direct integration, Linear equations of the first order-Lagrange’s linear equation, Non-linear equations of the first order -Charpit’s method, Solution of equation by method of separation of variables.

**Module 2 (Applications of Partial Differential Equations) (10 hours)**

**(Text 1-Relevant portions of sections 18.3,18.4, 18.5)**

One dimensional wave equation- vibrations of a stretched string, derivation, solution of the wave equation using method of separation of variables, D’Alembert’s solution of the wave equation, One dimensional heat equation, derivation, solution of the heat equation

**Module 3 (Complex Variable – Differentiation) (9 hours)**

**( Text 2: Relevant portions of sections13.3, 13.4, 17.1, 17.2 , 17.4)**

Complex function, limit, continuity, derivative, analytic functions, Cauchy-Riemann equations, harmonic functions, finding harmonic conjugate, Conformal mappings- mappings  $w = z^2$ ,  $w = e^z$ ,. Linear fractional transformation  $w = \frac{1}{z}$  , fixed points, Transformation  $w = \sin z$

(From sections 17.1, 17.2 and 17.4 only mappings  $w = z^2$ ,  $w = e^z$ ,  $w = \frac{1}{z}$ ,  $w = \sin z$  and problems based on these transformation need to be discussed)

**Module 4 (Complex Variable – Integration) (9 hours)**

**(Text 2- Relevant topics from sections14.1, 14.2, 14.3, 14.4,15.4)**

Complex integration, Line integrals in the complex plane, Basic properties, First evaluation method-indefinite integration and substitution of limit, second evaluation method-use of a representation of a path, Contour integrals, Cauchy integral theorem (without proof) on simply connected domain,Cauchy integral theorem (without proof) on multiply connected domain Cauchy Integral formula (without proof), Cauchy Integral formula for derivatives of an analytic function, Taylor’s series and Maclaurin series.,

**Module 5 (Complex Variable – Residue Integration) (9 hours)**

**(Text 2- Relevant topics from sections16.1, 16.2, 16.3, 16.4 )**

Laurent’s series(without proof ), zeros of analytic functions, singularities, poles, removable singularities, essential singularities, Residues, Cauchy Residue theorem (without proof), Evaluation of definite integral using residue theorem, Residue integration of real integrals – integrals of rational functions of  $\cos\theta$  and  $\sin\theta$  , integrals of improper integrals of the form

$\int_{-\infty}^{\infty} f(x) dx$  with no poles on the real axis. ( $\int_A^B f(x) dx$  whose integrand become infinite at a point in the interval of integration is excluded from the syllabus),

**Textbooks:**

1. B.S. Grewal, Higher Engineering Mathematics, Khanna Publishers, 44<sup>th</sup> Edition, 2018.
2. Erwin Kreyszig, Advanced Engineering Mathematics, 10<sup>th</sup> Edition, John Wiley & Sons, 2016.

**References:**

1. Peter V. O'Neil, Advanced Engineering Mathematics, Cengage, 7<sup>th</sup> Edition, 2012

**Assignments**

**Assignment:** Assignment must include applications of the above theory in the concerned engineering branches

**Course Contents and Lecture Schedule**

No	Topic	No. of Lectures
<b>1</b>	<b>Partial Differential Equations</b>	
1.1	Partial differential equations, Formation of partial differential equations –elimination of arbitrary constants-elimination of arbitrary functions, Solutions of a partial differential equations, Equations solvable by direct integration,	3
1.2	Linear equations of the first order- Lagrange’s linear equation, Non-linear equations of the first order - Charpit’s method	3
1.3	Boundary value problems, Method of separation of variables.	2
<b>2</b>	<b>Applications of Partial Differential Equations</b>	
2.1	One dimensional wave equation- vibrations of a stretched string, derivation,	1
2.2	Solution of wave equation using method of separation of variables, Fourier series solution of boundary value problems involving wave equation, D’Alembert’s solution of the wave equation	4
2.3	One dimensional heat equation, derivation,	1
2.4	Solution of the heat equation, using method of separation of variables, Fourier series solutions of boundary value problems involving heat equation	4

<b>3</b>	<b>Complex Variable – Differentiation</b>	
3.1	Complex function, limit, continuity, derivative, analytic functions, Cauchy-Riemann equations,	4
3.2	harmonic functions, finding harmonic conjugate,	2
3.3	Conformal mappings- mappings of $w = z^2$ , $w = e^z$ , $w = \frac{1}{z}$ , $w = \sin z$ .	3
<b>4</b>	<b>Complex Variable – Integration</b>	
4.1	Complex integration, Line integrals in the complex plane, Basic properties, First evaluation method, second evaluation method, use of representation of a path	4
4.2	Contour integrals, Cauchy integral theorem ( <b>without proof</b> ) on simply connected domain, on multiply connected domain( <b>without proof</b> ). Cauchy Integral formula ( <b>without proof</b> ),	2
4.3	Cauchy Integral formula for derivatives of an analytic function,	2
4.3	Taylor's series and Maclaurin series.	1
<b>5</b>	<b>Complex Variable – Residue Integration</b>	
5.1	Laurent's series( <b>without proof</b> )	2
5.2	zeros of analytic functions, singularities, poles, removable singularities, essential singularities, Residues,	2
5.3	Cauchy Residue theorem ( <b>without proof</b> ), Evaluation of definite integral using residue theorem	2
5.4	Residue integration of real integrals – integrals of rational functions of $\cos\theta$ and $\sin\theta$ , integrals of improper integrals of the form $\int_{-\infty}^{\infty} f(x)dx$ with no poles on the real axis. ( $\int_A^B f(x)dx$ whose integrand become infinite at a point in the interval of integration is excluded from the syllabus),	3

Model Question Paper

(For all branches except Computer Science and Information Technology)

(2019 Scheme)

Reg No:

Name:

APJ ABDULKALAM TECHNOLOGICAL UNIVERSITY  
THIRD SEMESTER B.TECH. DEGREE EXAMINATION  
(MONTH & YEAR)

Course Code:

Course Name: PARTIAL DIFFERENTIAL EQUATIONS AND COMPLEX ANALYSIS

MAX.MARKS: 100

DURATION: 3 Hours

**PART A**

**Answer all questions, each carries 3 marks.**

1. Derive a partial differential equation from the relation  $z = f(x + at) + g(x - at)$
2. Solve  $\frac{\partial^2 z}{\partial x \partial y} = x^2 y$
3. State any three assumptions in deriving the one dimensional wave equation
4. What are the possible solutions of one-dimensional heat equation?
5. If  $f(z) = u + iv$  is analytic, then show that  $u$  and  $v$  are harmonic functions.
6. Check whether  $f(z) = \bar{z}$  is analytic or not.
7. Evaluate  $\int_c \tan z \, dz$  where  $c$  is the unit circle.
8. Find the Taylor's series of  $f(z) = \frac{1}{z}$  about  $z = 2$ .
9. What type of singularity have the function  $f(z) = \frac{1}{\cos z - \sin z}$
10. Find the residue of  $\frac{e^z}{z^3}$  at its pole.

**PART B**

**Answer any one full question from each module, each question carries 14 marks.**

**Module-I**

11. (a) Solve  $x(y - z)p + y(z - x)q = z(x - y)$   
(b) Use Charpit's methods to solve  $q + xp = p^2$
12. (a) Find the differential equation of all spheres of fixed radius having their centers in the  $xy$ -plane.

- (b) Using the method of separation of variables, solve  $\frac{\partial u}{\partial x} = 2 \frac{\partial u}{\partial t} + u$ , where  $u(x, 0) = 6e^{-3x}$ .

**Module – II**

13. (a) Derive the solution of one dimensional wave equation  $\frac{\partial^2 u}{\partial t^2} = c^2 \frac{\partial^2 u}{\partial x^2}$  with zero boundary conditions and with initial conditions  $u(x, 0) = f(x)$  and  $\left(\frac{\partial u}{\partial t}\right)_{t=0} = 0$ .  
 (b) A homogeneous rod of conducting material of length 100 cm has its ends kept at zero temperature and the temperature initially is  $u(x, 0) = \begin{cases} x, & 0 \leq x \leq 50 \\ 100 - x, & 50 \leq x \leq 100 \end{cases}$ . Find the temperature  $u(x, t)$  at any time.
14. (a) A tightly stretched string of length  $l$  with fixed ends is initially in equilibrium position. It is set vibrating by giving each point a velocity  $v_0 \sin^3\left(\frac{\pi x}{l}\right)$ . Find the displacement of the string at any time.  
 (b) An insulated rod of length  $l$  has its ends A and B are maintained at  $0^\circ\text{C}$  and  $100^\circ\text{C}$  respectively under steady state condition prevails. If the temperature at B is suddenly reduced to  $0^\circ\text{C}$  and maintained at  $0^\circ\text{C}$ , Find the temperature at a distance  $x$  from A at time  $t$ .

**Module-III**

15. (a) Show that  $f(z) = e^z$  is analytic for all  $z$ . Find its derivative.  
 (b) Find the image of  $|z - 2i| = 2$  under the transformation  $w = \frac{1}{z}$
16. (a) Prove that the function  $u(x, y) = x^3 - 3xy^2 - 5y$  is harmonic everywhere. Find its harmonic conjugate.  
 (b) Find the image of the infinite stripe  $0 \leq y \leq \pi$  under the transformation  $w = e^z$

**Module-IV**

17. (a) Evaluate  $\int_0^{2+i} (\bar{z})^2 dz$ , along the real axis to 2 and then vertically to  $2 + i$   
 (b) Using Cauchy's integral formula evaluate  $\int_c \frac{5z+7}{z^2+2z-3} dz$ , where  $c$  is  $|z - 2| = 2$
18. (a) Evaluate  $\int_c \frac{\sin^2 z}{\left(z - \frac{\pi}{6}\right)^3} dz$ , where  $C$  is  $|z| = 1$ .  
 (b) Expand  $\frac{1}{(z-1)(z-2)}$  in the region  $|z| < 1$

**Module- V**

19. (a) Expand  $f(z) = \frac{z^2-1}{z^2-5z+6}$  in  $2 < |z| < 3$  as a Laurent's series.  
 (b) Using contour integration evaluate  $\int_0^{2\pi} \frac{d\theta}{2+\cos \theta}$
20. (a) Use residue theorem to evaluate  $\int_c \frac{\cos h \pi z}{z^2+4} dz$  where  $c$  is  $|z| = 3$ .  
 (b) Apply calculus of residues to evaluate  $\int_{-\infty}^{\infty} \frac{1}{(x^2+1)^3} dx$ .



CET201	MECHANICS OF SOLIDS	CATEGORY	L	T	P	CREDIT	Year of Introduction
		PCC	3	1	0	4	2019

**Preamble:**

Mechanics of solids is one of the foundation courses in the study of structural systems. The course provides the fundamental concepts of mechanics of deformable bodies and helps students to develop their analytical and problem solving skills. The course introduces students to the various internal effects induced in structural members as well as their deformations due to different types of loading. After this course students will be able to determine the stress, strain and deformation of loaded structural elements.

**Prerequisite:** EST 100 Engineering Mechanics

**Course Outcomes:** After the completion of the course the student will be able to

Course Outcome	Description of Course Outcome	Prescribed learning level
CO1	Recall the fundamental terms and theorems associated with mechanics of linear elastic deformable bodies.	Remembering
CO2	Explain the behavior and response of various structural elements under various loading conditions.	Understanding
CO3	Apply the principles of solid mechanics to calculate internal stresses/strains, stress resultants and strain energies in structural elements subjected to axial/transverse loads and bending/twisting moments.	Applying
CO4	Choose appropriate principles or formula to find the elastic constants of materials making use of the information available.	Applying
CO5	Perform stress transformations, identify principal planes/stresses and maximum shear stress at a point in a structural member.	Applying
CO6	Analyse the given structural member to calculate the safe load or proportion the cross section to carry the load safely.	Analysing

**Mapping of course outcomes with program outcomes (Minimum requirement)**

	PO1	PO2	PO3	PO4	PO5	PO6	PO7	PO8	PO9	PO10	PO11	PO12
CO1	1	-	-	-	-	-	-	-	-	-	-	-
CO2	2	1	-	-	-	-	-	-	-	-	-	-
CO3	3	2	-	-	-	-	-	-	-	-	-	-
CO4	3	2	-	-	-	-	-	-	-	-	-	-
CO5	3	2	-	-	-	-	-	-	-	-	-	-
CO6	3	3	1	-	-	-	-	-	-	-	-	-

**Assessment Pattern**

Bloom's Category	Continuous Assessment Tests		End Semester Examination
	1	2	
Remember	10	10	15
Understand	10	10	15
Apply	30	20	60
Analyse		10	10
Evaluate			
Create			

**Mark distribution**

Total Marks	CIE	ESE	ESE Duration
150	50	100	3 hours

**Continuous Internal Evaluation Pattern:**

Attendance : 10 marks  
 Continuous Assessment Test (2 numbers) : 25 marks  
 Assignment/Quiz/Course project : 15 marks

**End Semester Examination Pattern:** There will be two parts; Part A and Part B. Part A contain 10 questions with 2 questions from each module, having 3 marks for each question. Students should answer all questions. Part B contains 2 questions from each module of which student should answer any one. Each question carries 14 marks and can have maximum 2 sub-divisions.

**Course Level Assessment (Sample) Questions**

**CO1: Recall the fundamental terms and theorems associated with mechanics of linear elastic deformable bodies.**

1. What is proportionality limit? What is its significance?
2. Sketch the stress-strain curve of mild steel and mark the salient points
3. What is Poisson's ratio?
4. What is Bulk modulus of Elasticity? Write the relationship between Bulk modulus of elasticity and Young's modulus of elasticity.
5. What is pure bending? Give an example.
6. What is point of contraflexure?
7. What are the limitations of Euler's formula to calculate the buckling load of slender columns.
8. What is strain energy?
9. What is complementary shear stress?
10. What are principal stresses and principal planes?

**CO2: Explain the behavior and response of various structural elements under various loading conditions.**

1. Explain how the deformation of an axially loaded bar with uniformly varying cross section is calculated?
2. Explain the behavior of mild steel under gradually increasing tensile load.
3. Explain the effect of temperature change on a composite bar made of two materials.
4. How do you compute the maximum stress induced in a bar due to impact load?
5. Explain the concept of BM and SF in beams, with the help of a cantilever beam subjected to uniformly distributed load over the whole span.
6. List three important assumptions used in the theory of pure bending and explain their significance.
7. Explain the behavior of slender columns under axial compressive load.
8. Distinguish between short and long columns with reference to their behavior under axial compression.
9. Explain how the limitation of Euler's formula to calculate buckling load of columns is addressed in Rankine's formula.

**CO3: Apply the principles of solid mechanics to calculate internal stresses/strains, stress resultants and strain energies in structural elements subjected to axial/transverse loads and bending/twisting moments.**

1. A steel flat of cross section  $25 \text{ mm} \times 6 \text{ mm}$  carries a tensile load of  $12 \text{ kN}$ . Find the stress induced in the cross section. If a circular hole of diameter  $12 \text{ mm}$  is made (normal to the flat surface), find the maximum stress induced in the cross section.
2. The bar ABC shown in figure is made of steel and has circular cross section. The bar BD is rigid. Find the stresses in portions AB and BC and the vertical deflection at C. Take  $E = 210 \text{ GPa}$ .

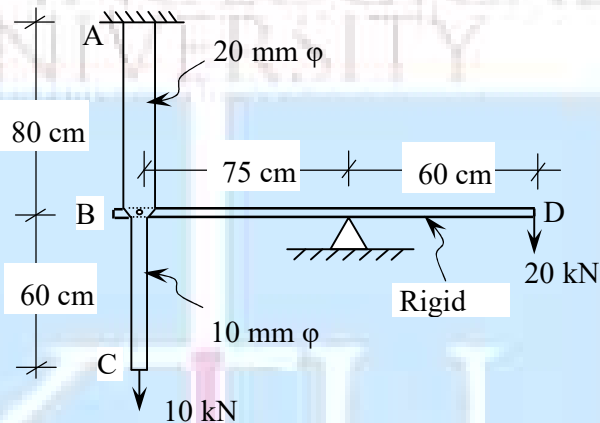

3. A rigid bar AB of length  $100 \text{ cm}$ , hinged at one end is supported by a steel rod and a copper wire as shown. Find the stresses induced in the rod and wire due to a downward load acting at  $70 \text{ cm}$  from the hinged end of the bar. Calculate the vertical deflection at B also. Modulus of elasticity of steel and copper are  $200 \text{ GPa}$  and  $80 \text{ GPa}$  respectively. Neglect the weight of the rigid bar.

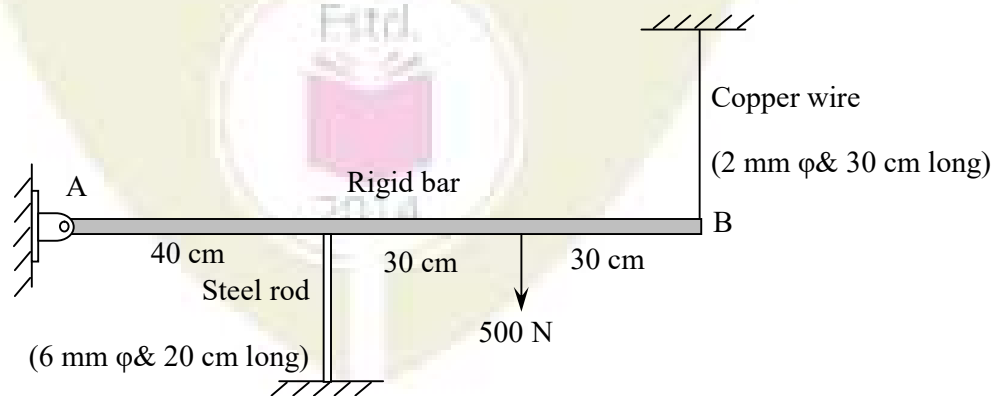

4. A 32 mm diameter steel bar is subjected to forces as shown in figure. Find the value of  $P$  necessary for equilibrium and stresses in different segments. Also calculate the final length of the bar. Take  $E = 200 \text{ GPa}$ .

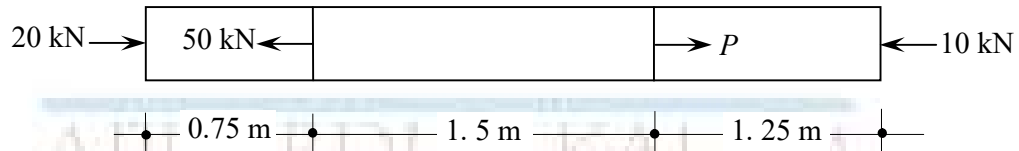

4. A cylindrical bar with two sections of lengths 50 cm and 25 cm, and diameters 20 mm and 15 mm respectively is subjected to an axial pull such that the maximum stress is  $150 \text{ MN/m}^2$ . Calculate the strain energy stored in the bar.  $E=200 \text{ GN/m}^2$
5. Draw the SFD and BMD of the beam shown.

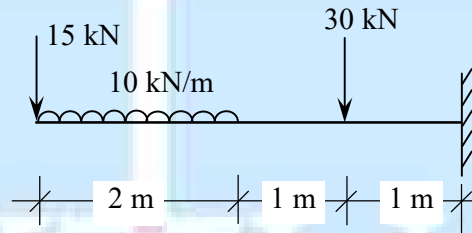

6. Figure shows the cross section of a beam. Find the stresses (both magnitude and nature) at points A,B,C,D,E and F, if the section carries a BM of 12 kNm. Draw the variation of stress across the cross section. Also calculate the shear stress at these points if the cross section carries a SF of 50 kN.

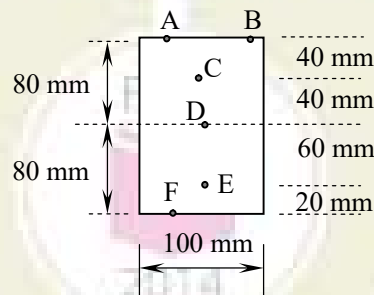

**CO4: Choose appropriate principles or formula to find the elastic constants of materials making use of the information available.**

1. A concrete cylinder of diameter 150 mm and height 300 mm is tested under compression. It was found that the diameter was increased by 0.0102 mm and the height was decreased by 0.165 mm under the action of a compressive load of 200 kN. Calculate the modulus of elasticity, Poisson's ratio, bulk modulus and shear modulus of concrete.

2. A tension test is carried out on a mild steel bar of 10 mm diameter. The bar yields under a load of 20 kN, it reaches a maximum load of 40 kN and breaks at 25 kN. The diameter of the bar at breaking was found to be 7 mm. The increase in length of the bar over a gauge length of 50 mm was found to be 0.029 mm under a load of 10 kN. Estimate (a) Young's modulus, (b) yield strength, (c) ultimate strength and (d) actual breaking strength

**CO5: Perform stress transformations, identify principal planes/stresses and maximum shear stress at a point in a structural member.**

1. A bar of 12 mm diameter carries an axial pull of 15 kN. Find the normal and shear stress on a plane inclined at  $60^\circ$  with the axis of the bar. What is the maximum shear stress induced in the bar and the inclination of the corresponding plane?
2. At a certain point in a strained material, the stresses on two planes at right angles to each other are 50 MPa (tensile) and 80 MPa (compressive). They are accompanied by a shear stress of magnitude 20 MPa. Find the principal stresses and locate their planes. Also find the maximum shear stress and resultant stress on the plane of maximum shear stress.

**CO6: Analyse the given structural member to calculate the safe load or proportion the cross section to carry the load safely.**

1. A timber beam 150 mm  $\times$  200 mm is used as a simply supported beam of span 3 m. Find the maximum uniformly distributed load that can be applied in addition to a concentrated load of 5 kN acting at the mid span, if the maximum bending stress in the beam is not to exceed  $8 \text{ N/mm}^2$ . Neglect self weight of beam.
2. A 3 m long cantilever beam of rectangular section is required to carry a udl of 10 kN/m over the whole span. If the maximum bending stress is limited to  $12 \text{ N/mm}^2$ , find the dimensions of the cross section assuming depth to width ratio as 2.
3. A cast iron test beam 25 mm square in section and 700 mm long is simply supported at ends. It fails under a central load of 2300 N. What load at the free end will break a cantilever of the same material 50 mm wide  $\times$  100 mm deep and 1500 mm long?
4. A solid circular shaft transmits 80 kW power at 190 rpm. Calculate the diameter of the shaft if the twist in the shaft is not to exceed  $1^\circ$  in 2 m length of shaft and shear stress is limited to 60 MPa. Take  $G = 100 \text{ GPa}$ .

## SYLLABUS

**Module – 1**

Review of statics, Concept of stress and strain – types, Stress – strain relation - Hooke's law, Young's modulus of elasticity.  
 Stress-strain diagram of mild steel.  
 Factor of safety, working stress.  
 Axially loaded bars with uniform cross section–stress, strain and deformation.  
 Deformation of axially loaded bars with varying cross section and bars with varying axial loads.  
 Statically indeterminate systems (number of unknowns restricted to two).

**Module – 2**

Temperature effects, temperature stress in composite bars.  
 Shear stress and shear strain, Modulus of rigidity, simple shear, punching shear.  
 Lateral strain, Poisson's ratio, volumetric strain.  
 Bulk modulus of elasticity, relationships between elastic constants.  
 Strain energy – concept. Strain energy due to normal stress.  
 Strain energy in bars carrying axial loads.  
 Instantaneous stress in bars due to gradual, sudden and impact loads. Strain energy due to shear stress.  
 Stresses in thin cylinders and spheres due to internal pressure.

**Module – 3**

Beams – different types. Types of loading on beams. Concept of bending moment and shear force.  
 Relationship between intensity of load, shear force and bending moment.  
 Shear force and bending moment diagrams of cantilever beams, simply supported beams and overhanging beams for different type of loads. Point of contraflexure.

**Module – 4**

Theory of simple bending, assumptions and limitations.  
 Calculation of normal stress in beams, moment of resistance  
 Shear stress in beams.  
 Beams of uniform strength.  
 Strain energy due to bending – calculation of strain energy in beams.  
 Differential equation for calculating the deflection of beams. (Introduction and demonstration only.  
 Students are not expected to solve deflection problems.)

**Module – 5**

Stresses on inclined sections for uniaxial and biaxial stress fields.  
 Principal stresses and principal planes in 2D problems, maximum shear stress.  
 Strains along principal directions.  
 Mohr's circle of stress for 2D problems.  
 Short columns – direct and bending stress. Kern of a section.  
 Slender columns – Euler's buckling load, slenderness ratio, limitation of Euler's formula.  
 Rankines formula.  
 Torsion of circular and hollow circular shafts, Power transmitted by circular shafts and hollow circular shafts. Strain energy due to torsion.

**Text Books:**

1. H. J. Shah and S. B. Junnarkar, Mechanics of Structures Vol - I, Charotar Publishing House.
2. R. K. Bansal, A Text book of Strength of Materials, Laxmi Publications (P) Ltd, New Delhi.
3. B. C. Punmia, Ashok K. Jain, Arun Kumar Jain, Mechanics of Materials, Laxmi Publications (P) Ltd, New Delhi.

**References:**

1. Egor P. Popov, Engineering Mechanics of Solids, Prentice Hall International Series.
2. James M Gere, S.P. Timoshenko, Mechanics of Materials, CBS Publishers and Distributors, New Delhi.
3. R.C. Hibbeler, Mechanics of Materials (edn.10), Pearson
4. S. Ramamrutham and R. Narayanan, Strength of Materials, Dhanpat Rai Publishing Co (P) Ltd.
5. Rattan, Strength of Materials, McGraw Hill Education India.

**Lecture Plan –Mechanics of Solids**

<i>Module</i>	<i>Topic</i>	<i>Course Outcomes addressed</i>	<i>No. of Lectures</i>
<b>1</b>	<b>Module I : Total lecture hours : 8</b>		
1.1	Review of statics – equilibrium conditions, free body diagrams, centroid, moment of inertia.	-	1
1.2	Concept of stress, types of stresses. Concept of strain ,types of strains. Stress – strain relation - Hooke’s law, Young’s modulus of elasticity.	CO1, CO2, CO4	1
1.3	Stress-strain ( $\sigma - \epsilon$ ) diagram of mild steel – proportional limit, yield point, ultimate stress, fracture. True and engineering $\sigma - \epsilon$ curve, idealized $\sigma - \epsilon$ curves. Factor of safety, working stress.	CO1, CO2	1
1.4	Axially loaded bars with uniform cross section– calculation of stress, strain and deformation.	CO2, CO3	1
1.5	Deformation of axially loaded bars with varying cross section. Stepped bars, bars with tapering cross section	CO3	1
1.6	Deformation of axially loaded bars with varying axial loads – elongation of bars under self weight, elongation/contraction of uniform/stepped bars.	CO3	1
1.7	Statically indeterminate systems – analysis of axially loaded composite bars (with maximum two materials)	CO3, CO6	1
1.8	Analysis of indeterminate systems with axial load carrying members (number of unknowns restricted to two). (Example: Assessment Level Question 3 of CO3)	CO3, CO6	1



<b>2</b>	<b>Module II : Total lecture hours : 8</b>		
2.1	Temperature effects, temperature stress in composite bars.	CO2, CO3	1
2.2	Shear stress and shear strain, Modulus of rigidity, simple shear, punching shear.	CO1, CO2, CO3, CO4	1
2.3	Lateral strain, Poisson's ratio, volumetric strain. Volumetric strain of rectangular bar, circular bar and sphere. Volumetric strain expressed in terms of strains along three mutually perpendicular directions.	CO2, CO3	1
2.4	Bulk modulus of elasticity, relationships between elastic constants.	CO1, CO4	1
2.5	Strain energy – concept. Resilience, modulus of resilience and proof resilience. Strain energy due to normal stress. Calculation of total strain energy in bars carrying axial loads. Strain energy due to shear stress.	CO1, CO2, CO3	2
2.6	Instantaneous stress in bars due to gradual, sudden and impact loads.	CO1, CO2, CO3	1
2.7	Stresses in thin cylinders and spheres due to internal pressure	CO1, CO2, CO3	1
<b>3</b>	<b>Module III : Total lecture hours : 8</b>		
3.1	Beams – different types. Types of loading on beams. Concept of bending moment and shear force. Shear force and bending moment diagrams.	CO1, CO2	1
3.2	Relationship between load, shear force and bending moment. Demonstration using simple examples.	CO1	1
3.3	Shear force and bending moment diagrams of cantilever beams subjected to point load, concentrated moments, uniformly distributed and uniformly varying loads.	CO2	2
3.4	Shear force and bending moment diagrams of simply supported beams subjected to point load, concentrated moment, uniformly distributed and uniformly varying loads.	CO2	2
3.5	Shear force and bending moment diagrams of overhanging beams subjected to point load, concentrated moment and uniformly distributed loads. Point of contraflexure.	CO1, CO2	2
<b>4</b>	<b>Module IV : Total lecture hours : 9</b>		
4.1	Theory of simple bending – derivation of equation, assumptions and limitations.	CO1, CO2	1
4.2	Variation of bending stress across the cross section. Maximum bending stress, section modulus, moment of resistance.	CO1, CO2	1
4.3	Calculation of normal stress in beams. Problems involving bending stress	CO3	1

4.4	Shear stress in beams – derivation of equation. Variation of shear stress across the cross section. (Derivation required for rectangular, circular and triangular sections only)	CO1, CO2	1
4.5	Calculation of shear stress- problems involving shear stress.	CO3	1
4.6	Calculation of allowable loads in beams based on bending stress and shear stress criteria.	CO6	1
4.7	Proportioning beam sections to carry given load without exceeding the allowable bending stress and/ shear stress. Beams of uniform strength.	CO6	1
4.8	Strain energy due to bending – calculation of strain energy in beams. (Cantilever and simply supported beams subjected to point load and uniformly distributed load)	CO1, CO2, CO3	1
4.9	Moment-curvature relation. Basic differential equation for calculating the deflection of beams. Simple example to calculate deflection of beams (such as cantilever beam with point load at free end) for demonstration purpose.	CO1	1
<b>5</b>	<b>Module V : Total lecture hours : 12</b>		
5.1	Stresses on inclined planes for uniaxial and biaxial stress fields. Element subjected to pure shear.	CO3	2
5.2	Principal stresses and principal planes in 2D problems, maximum shear stress. Strains along principal directions.	CO1, CO3, CO5	2
5.3	Mohr’s circle of stress for 2D problems.	CO3, CO5	1
5.4	Short columns – direct and bending stress. Kern of a section (concept only).	CO1,CO2, CO3	1
5.5	Slender columns –Buckling, Euler’s buckling load for columns with pinned ends. Eulers’ buckling load for columns with different end conditions (no derivation required). Effective length of columns with different end conditions.	CO1,CO2, CO3	2
5.6	Slenderness ratio, limitation of Euler’s formula. Rankine’s formula. Safe load calculation using Rankine’s formula (demonstration only).	CO1,CO2, CO3	1
5.7	Torsion of circular and hollow circular shafts, assumptions, derivation of torsion equation. Variation of stress across the cross section.Polar modulus.	CO1,CO2, CO3	1
5.8	Power transmitted by circular shafts and hollow circular shafts. Proportioning the shafts to transmit a given power based on shear stress and angle of twist considerations Strain energy due to torsion.	CO3, CO6	2

**MODEL QUESTION PAPER**

Reg.No.: \_\_\_\_\_

Name: \_\_\_\_\_

**APJ ABDUL KALAM TECHNOLOGICAL UNIVERSITY  
THIRD SEMESTER B.TECH DEGREE EXAMINATION**

**Course Code: CET201**

**Course Name: MECHANICS OF SOLIDS**

Max. Marks: 100

Duration: 3 Hours

**PART A**

*Answer all questions; each question carries 3 marks.*

1. a) Define the terms (i) proportionality limit, (ii) ultimate stress (ii) working stress.
- b) Explain, how the deformation of an axially loaded bar with uniformly varying cross section is calculated?
- c) Explain the effect of temperature change on a composite bar made of two materials.
- d) What is Bulk modulus of Elasticity? Write the relationship between Bulk modulus of elasticity and Young's modulus of elasticity.
- e) What is the relationship between intensity of load, SF and BM?
- f) Explain the concept of BM and SF in beams, with the help of a cantilever beam subjected to uniformly distributed load over the whole span.
- g) What is pure bending? Give an example.
- h) List three important assumptions used in the theory of pure bending and their significance.
- i) What are principal stresses and principal planes?
- j) Distinguish between short and long columns with reference to their behavior under axial compression.

(10×3 marks = 30 marks)

**PART B**

*Answer one full question from each module; each full question carries 14 marks.*

**Module I**

2. A bar of circular cross section has three segments as shown in figure. The portion AB has a constant diameter of 25 mm. The portion BC has diameter 25 mm at B and tapers uniformly to diameter 'd' at C. The portion CD has a constant diameter of 'd'. The bar was found to elongate by 0.539 mm under an axial tension of 20 kN. Find the value of 'd'. Take Young's modulus of elasticity of the material as 200 GPa.

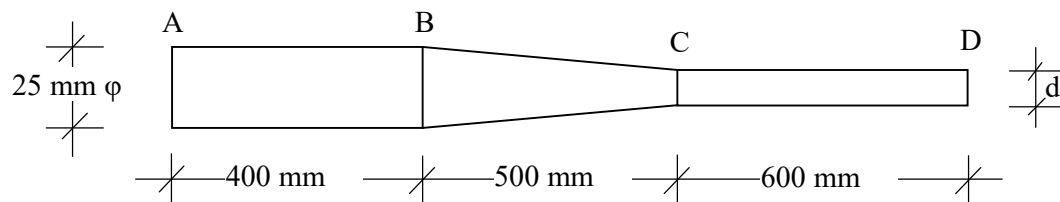

3. A steel rod of 25 mm diameter is placed in a hollow aluminium cylinder with internal diameter 30 mm and external diameter 40 mm. The steel rod projects 0.1 mm as shown. The bar carries a compressive force of 70 kN through a rigid bearing plate. Find the stresses in steel and aluminium bars.  $E_s = 200 \text{ GPa}$  and  $E_{al} = 120 \text{ GPa}$

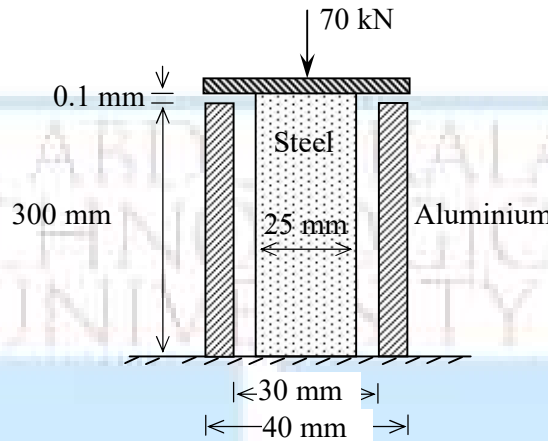

**Module II**

4. A concrete cylinder of diameter 150 mm and height 300 mm is tested under axial compression. It was found that the diameter was increased by 0.0102 mm and the height was decreased by 0.165 mm under the action of a compressive load of 200 kN. Calculate the modulus of elasticity, Poisson's ratio, bulk modulus and shear modulus of concrete.
5. A compound bar is made of a central steel plate 60 mm wide and 10 mm thick to which copper plates 40 mm wide and 5mm thick are rigidly connected on each side. The length of the bar at normal temperature is 1 m. If the temperature is raised by  $80^\circ\text{C}$ , determine the stress in each metal and the change in length.  $E_s = 2 \times 10^5 \text{ N/mm}^2$ ,  $\alpha_s = 12 \times 10^{-6} / ^\circ\text{C}$ ,  $E_c = 1.05 \times 10^5 \text{ N/mm}^2$  and  $\alpha_c = 17.5 \times 10^{-6} / ^\circ\text{C}$ .

**Module III**

6. Draw the SFD and BMD of the beam loaded as shown in figure. Find the maximum BM and locate the point of maximum BM also.

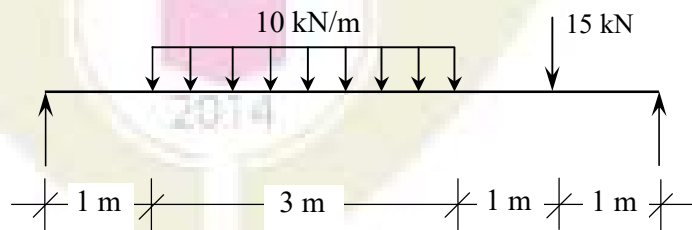

7. An overhanging beam is loaded as shown. Draw SFD and BMD. Locate the point of contraflexure also.

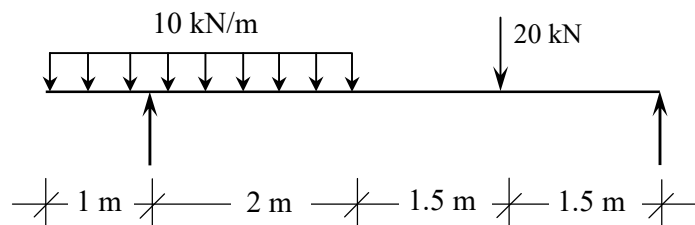

**Module IV**

8. a) A simply supported beam of triangular cross section, having width 160 mm and height 210 mm, carries a udl of 2 kN/m over a span of 4m. Find the maximum tensile and compressive stresses induced. Draw the variation of stress across the cross section. (10 marks)
- b) Calculate the total strain energy due to bending in a cantilever beam of span  $L$  carrying a point load  $W$  at its free end. (4 marks)
9. a) A timber beam 150 mm  $\times$  200 mm (width = 150 mm) is used as a simply supported beam of span 3 m. Find the maximum uniformly distributed load that can be applied in addition to a concentrated load of 5 kN acting at the mid span, if the maximum bending stress and shear stress in the beam are not to exceed 15 N/mm<sup>2</sup> and 2 N/mm<sup>2</sup> respectively. Neglect self weight of beam. (10 marks)
- b) What is beam of uniform strength? Give an example. (4 marks)

**Module V**

10. A point in a strained body is subjected to stresses as shown in figure. Find the principal stresses and maximum shear stress. Also locate the principal planes and planes of maximum shear stress, with respect to the vertical plane. Calculate the strains along the direction of the principal stresses also. Take  $E = 200$  GPa and  $\nu = 0.25$ .

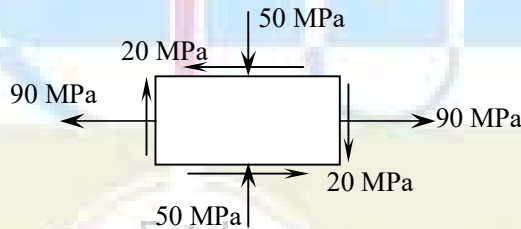

11. A solid circular shaft transmits 80 kW power at 190 rpm. Calculate the diameter of the shaft if the twist in the shaft is not to exceed 1° in 2 m length of shaft and shear stress is limited to 60 MPa. Take  $G = 100$  GPa.

\*\*\*\*\*

CET 203	Fluid Mechanics and Hydraulics	Category	L	T	P	Credit	Year of Introduction
		PCC	3	1	0	4	2019

**Preamble:** Goal of this course is to expose the students to the fundamental concepts of fluid mechanics, hydraulics of pipes and open channels and to enhance the problem solving skills. The concepts learned will help in applying them for the design of hydraulic structures and to real world fluid flow problems.

**Pre-requisite:** Elementary mathematics, concepts in engineering mechanics

**Course outcome**

After the course, the student will able to:

CO1	Recall the relevant principles of hydrostatics and hydraulics of pipes and open channels
CO2	Identify or describe the type, characteristics or properties of fluid flow
CO3	Estimate the fluid pressure, perform the stability check of bodies under hydrostatic condition
CO4	Compute discharge through pipes or estimate the forces on pipe bends by applying hydraulic principles of continuity, energy and/or momentum
CO5	Analyze or compute the flow through open channels, perform the design of prismatic channels

CET 203 Fluid Mechanics and Hydraulics		PO1	PO2	PO3	PO4	PO5	PO6	PO7	PO8	PO9	PO10	PO11	PO12
	CO1	2	2										
	CO2	2	2										
	CO3	3	3				1						
	CO4	3	3				1						
	CO5	3	3	2									

**Assessment pattern**

Bloom's Category	Continuous Assessment Tests		End Semester Examination (Marks)
	Test 1 (Marks)	Test 2 (Marks)	
Remember	5	5	15
Understand	10	10	15
Apply	20	20	40
Analyze	15	15	30

Evaluate			
Create			

**Continuous Internal Evaluation Pattern:**

Attendance	:	10 marks
Continuous Assessment Test(2 numbers)	:	25 marks
Assignment/Quiz/Course project	:	15 marks
<b>Total</b>	:	<b>50 marks</b>

**End semester examination pattern** – There will be two parts; Part A and Part B. Part A contain 10 questions with 2 questions from each module, having 3 marks for each question. Students should answer all questions. Part B contains 2 questions from each module of which student should answer any one. Each question can have maximum 2 sub-divisions and carry 14 marks.

Qn No	Question	Marks	Course outcome (CO) Assessed
<b>Part A</b> <b>(Answer ALL Questions)</b>			
1	Explain the method of estimation of hydrostatic force on curved surfaces	3	CO1
2	Compare the use of piezometer and manometer for pressure measurement	3	CO1
3	Explain the experimental method of determination of metacentric height	3	CO1
4	Define streamline, streakline and pathline	3	CO2
5	Explain the use and principle of Pitot tube	3	CO1
6	Obtain the discharge equation of a large rectangular orifice	3	CO2
7	Explain conveyance and section factor for uniform flow and their practical applications	3	CO1
8	Obtain the condition for maximum velocity through	3	CO1

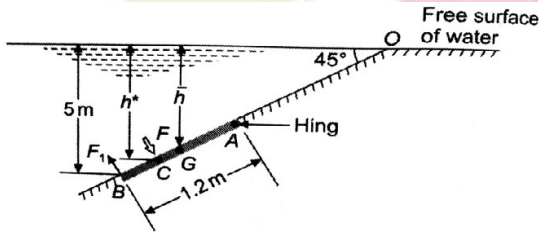
	circular channels		
9	State the assumptions involved in the derivation of dynamic equation of gradually varied low	3	CO1
10	Explain the classification of hydraulic jumps based on Froude's Number	3	CO1
	<b>Part B</b> (Answer ANY ONE FULL question from each module)		
	<b>Module I</b>		
11(a)	Differentiate gauge pressure, atmospheric pressure and absolute pressure	4	CO1
11(b)	A U-tube manometer is used to measure the pressure of water in a pipeline which is in excess of atmospheric. The left limb is connected to the pipeline and right limb is open to atmosphere. The free surface of mercury in the right limb is in level with the centre line of the pipe and the level difference of mercury in the limbs of the manometer is 20 cm. Compute the water pressure in the pipeline. If the pressure of water is increased by 50 %, compute the manometric reading.	10	CO3
12(a)	Obtain the expression for centre of pressure of a lamina placed in fluid in vertical position	4	CO1
12(b)	An inclined rectangular sluice gate AB 1.2m by 5m as shown in fig is installed to control the discharge of water. The end A is hinged. Determine the force normal to gate applied at B to open it. 	10	CO3
	<b>Module II</b>		
13(a)	Find the acceleration at (1, 2, 3) after 1 sec for a 3D flow given by $u=yz+t$ , $v=xz-t$ , $w=xy$	6	CO2
13(b)	Derive continuity equation in 3D Cartesian coordinates	8	CO1



14(a)	A solid cylinder 2 m in diameter and 2 m in length floats in water with its axis vertical. If the specific gravity of the material of the cylinder is 0.65, find the metacentric height and comment on the stability of the body	6	CO3
14(b)	Explain the stability conditions of floating bodies and submerged bodies	8	CO1
<b>Module III</b>			
15	Gasoline (specific gravity 0.82) flows at a rate of 215 l/s in upward direction through an inclined venturimeter fitted to a 300 mm diameter pipe. The venturimeter is inclined at $60^\circ$ to vertical and its 150 mm diameter throat is 1.2 m from the entrance along its length. Pressure gauges inserted at the inlet and throat show pressures of $0.141 \text{ N/mm}^2$ and $0.077 \text{ N/mm}^2$ respectively. Compute the coefficient of discharge of the venturimeter. If instead of pressure gauges, the entrance and throat are connected to two limbs of a mercury u-tube manometer, determine the manometric reading.	14	CO4
16	A pipeline of 600 m diameter is 1.5 km long. To increase the discharge, another pipe of same diameter is introduced in parallel to the first pipe, for the second half of length. If $f=0.04$ , and head at inlet is 300 mm, calculate the increase in discharge. Neglect minor losses.	14	CO4
<b>Module IV</b>			
17(a)	Explain the characteristics of velocity distribution in open channels	4	CO2
17(b)	A lined canal $n=0.014$ is of trapezoidal section with one side vertical and other with a slope of 1.5H:1 V. If the channel is to deliver $9 \text{ m}^3/\text{sec}$ when laid on a slope of 0.0002, calculate the dimensions of the efficient section that requires minimum lining.	10	CO5
18(a)	Obtain the discharge equation of a Cipoletti weir	4	CO2
18(b)	A 40 m long weir is divided into 12 equal bays by vertical posts, each 0.6 m wide. Using Francis formula, calculate the discharge over the weir if the head over the crest is 1.2 m and velocity of approach is 2 m/sec	10	CO5
<b>Module V</b>			
19 (a)	State the characteristics of M type profiles	4	CO2

19 (b)	A very wide rectangular channel carries a discharge of 8 cumecs per m width. The channel has a bed slope of 0.004 and Manning's roughness coefficient 0.015. Find the distance to a section where water depth is 0.9 m using single step method	10	CO5
20 (a)	Show that minimum specific force for a given discharge indicate the critical flow in open channels	4	CO2
20 (b)	The energy loss and Froude number after the jump in a horizontal rectangular channel are 9.00 and 0.12 respectively. Determine the depth before the jump will be and the power lost per m width of the channel	10	CO5

**Model Question Paper**

Reg No.:.....

QP CODE:.....

Name:.....

**APJ ABDUL KALAM TECHNOLOGICAL UNIVERSITY  
THIRD SEMESTER B.TECH DEGREE EXAMINATION, MONTH & YEAR**

Course Code: CET203

**Fluid Mechanics and Hydraulics**

Max. Marks: 100

Duration: 3 hours

**Part A****(Answer all questions; each question carries 3 marks)**

1. Explain the method of estimation of hydrostatic force on curved surfaces
2. Compare the use of piezometer and manometer for pressure measurement
3. Explain the experimental method of determination of metacentric height
4. Define streamline, streakline and pathline
5. Explain the use and principle of Pitot tube
6. Obtain the discharge equation of a large rectangular orifice
7. Explain conveyance and section factor for uniform flow and their practical applications
8. Obtain the condition for maximum velocity through circular channels
9. State the assumptions involved in the derivation of dynamic equation of gradually varied flow

10. Explain the classification of hydraulic jumps based on Froude's Number

(3 Marks x 10 = 30 Marks)

**Part B**

(Answer one full question from each module, each question carries 14 marks)

**Module I**

11 (a) Differentiate gauge pressure, atmospheric pressure and absolute pressure (4 Marks)

(b) A U-tube manometer is used to measure the pressure of water in a pipeline which is in excess of atmospheric. The left limb is connected to the pipeline and right limb is open to atmosphere. The free surface of mercury in the right limb is in level with the centre line of the pipe and the level difference of mercury in the limbs of the manometer is 20 cm. Compute the water pressure in the pipeline. If the pressure of water is increased by 50 %, compute the manometric reading. (10 Marks)

**OR**

12.(a) Obtain the expression for centre of pressure of a lamina placed in fluid in vertical position (4 Marks)

(b) An inclined rectangular sluice gate AB 1.2m by 5m as shown in fig is installed to control the discharge of water. The end A is hinged. Determine the force normal to gate applied at B to open it. (10 Marks)

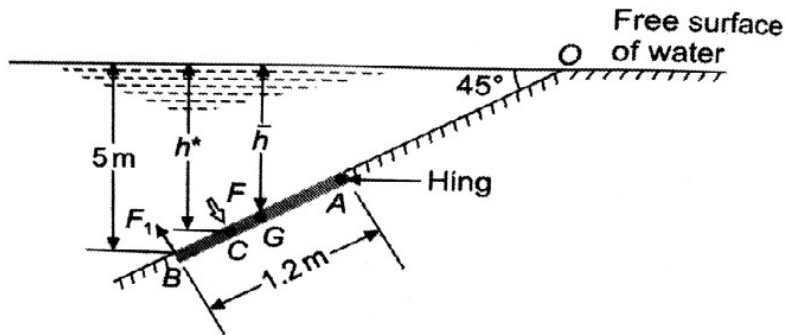

**Module II**

13.(a) Find the acceleration at (1, 2, 3) after 1 sec for a 3D flow given by  $u=yz+t$ ,  $v=xz-t$ ,  $w=xy$

(6 Marks)

(b) Derive continuity equation in 3D Cartesian coordinates

(8 Marks)

**OR**

14. (a) A solid cylinder 2 m in diameter and 2 m in length floats in water with its axis vertical. If the specific gravity of the material of the cylinder is 0.65, find the metacentric height and comment on the stability of the body. (6 Marks)
- (b) Explain the stability conditions of floating and submerged bodies (8 Marks)

### Module III

15. Gasoline (specific gravity 0.82) flows at a rate of 215 l/s in upward direction through an inclined venturimeter fitted to a 300 mm diameter pipe. The venturimeter is inclined at  $60^\circ$  to vertical and its 150 mm diameter throat is 1.2 m from the entrance along its length. Pressure gauges inserted at the inlet and throat show pressures of  $0.141 \text{ N/mm}^2$  and  $0.077 \text{ N/mm}^2$  respectively. Compute the coefficient of discharge of the venturimeter. If instead of pressure gauges, the entrance and throat are connected to two limbs of a mercury u-tube manometer, determine the manometric reading. (14 Marks)

OR

16. A pipeline of 600 m diameter is 1.5 km long. To increase the discharge, another pipe of same diameter is introduced in parallel to the first pipe, for the second half of length. If  $f=0.04$ , and head at inlet is 300 mm, calculate the increase in discharge. Neglect minor losses. (14 Marks)

### Module IV

- 17 (a) Explain the characteristics of velocity distribution in open channels (4 Marks)
- (b) A lined canal  $n=0.014$  is of trapezoidal section with one side vertical and other with a slope of 1.5H:1 V. If the channel is to deliver  $9 \text{ m}^3/\text{sec}$  when laid on a slope of 0.0002, calculate the dimensions of the efficient section that requires minimum lining. (10 Marks)

OR

- 18 (a) Obtain the discharge equation of a Cipoletti weir (4 Marks)
- (b) A 40 m long weir is divided into 12 equal bays by vertical posts, each 0.6 m wide. Using Francis formula, calculate the discharge over the weir if the head over the crest is 1.2 m and velocity of approach is 2 m/sec (10 Marks)

### Module V

- 19 (a) State the characteristics of M type profiles (4 Marks)

- (b) A very wide rectangular channel carries a discharge of 8 cumecs per m width. The channel has a bed slope of 0.004 and Manning's roughness coefficient 0.015. Find the distance to a section where water depth is 0.9 m using single step method. (10 Marks)

**OR**

- 20.(a) Show that minimum specific force for a given discharge indicate the critical flow in open channels. (4 Marks)
- (b) The energy loss and Froude number after the jump in a horizontal rectangular channel are 9.00 and 0.12 respectively. Determine the depth before the jump will be and the power lost per m width of the channel. (10 Marks)

**Course Code: CET203**  
**Fluid Mechanics and Hydraulics**  
**Syllabus**

**Module I**

Introduction to the subject-Fluid properties (mass density, specific weight, viscosity, specific gravity), Classification of Fluids (prerequisite no questions from this section)  
 Fluid statics-variation of pressure in a fluid, measurement of fluid pressure using piezometers and manometers, U-tube manometers, Forces on immersed plane placed vertical and inclined positions. Hydrostatic force on curved surfaces – Practical application of total pressure on spillway gates.

**Module II**

Buoyancy and Floatation: Buoyant force, Principle of floatation, stability of floating and submerged bodies, metacentre and metacentric height, analytical and experimental determination of metacentric height  
 Hydrodynamics- Methods of describing fluid motion, Lagrangian and Eulerian methods, velocity and acceleration, types of fluid flow, description of fluid flow- streamline, pathline and streakline; continuity equation in one, two and three dimensions

**Module III**

Fluid kinetics-forces considered in describing fluid motion, Derivation of Bernoulli's equation by integration of Euler's equation along a streamline, kinetic energy correction factor, Applications of Bernoulli's equation- Venturimeter, Pitot tube and Orificemeter; Hydraulic

coefficients of orifices and their experimental determination, Discharge through small orifice and large rectangular orifices

Pipe flow- computation of major and minor losses in pipes, hydraulic gradient line and total energy line, pipes in series-equivalent pipe, flow through parallel pipes.

#### **Module IV**

Open channel flow – comparison between pipe flow and open channel flow, velocity distribution in open channels, types of channels, type of flow, geometric elements of channel section, uniform flow computations (Chezy's equation, Kutter's and Manning's formula); Most economical sections – rectangular, triangular and trapezoidal channels, condition for maximum discharge and maximum velocity through circular channels, conveyance and section factor  
Flow measurement in channels – notches and weirs – Discharge computations using weirs-velocity of approach and end contraction, discharge equations of rectangular weir, triangular weir, trapezoidal and Cipoletti weir, submerged weir, broad crested weir.

#### **Module V**

Specific energy- specific energy diagram and discharge diagram, Critical flow and its computation.

Gradually varied flow- Dynamic equation of gradually varied flow-different forms, types and characteristics of water surface profiles in rectangular prismatic channels. Computation of length of water surface profiles by direct step method

Specific force, Rapidly varied flow-Hydraulic jump-conjugate or sequent depths, expression for sequent depths and energy loss for a hydraulic jump in horizontal rectangular channels, types uses and characteristics of hydraulic jump

#### **Text Books**

1. Modi P. N. and S. M. Seth, Hydraulics & Fluid Mechanics, S.B.H Publishers, New Delhi, 2002.
2. Subramanya K., Theory and Applications of Fluid Mechanics, Tata McGraw-Hill, 1993.
3. Subramanya K., Flow in Open channels, Tata McGraw-Hill, 2009.

#### **References**

1. Streeter.V.L. Fluid Mechanics, Mc Graw Hill Publishers.
2. Bruce R Munson, Donald F Young . Fundamentals of Fluid Mechanics, John Wiley & sons, 2011.
3. Jain A. K., Fluid Mechanics, Khanna Publishers, Delhi, 1996.
4. Joseph Katz, Introductory Fluid Mechanics, Cambridge University Press, 2015
5. Arora.K.R. Fluid Mechanics, Hydraulics and Hydraulic Machines, Standard Publishers, 2005.

6. Narasimhan S., A First Course in Fluid Mechanics, University Press (India) Pvt. Ltd., 2006.
7. Frank.M.White, Fluid Mechanics, Mc Graw Hill, 2013.
8. Mohanty.A.K. Fluid Mechanics, Prentice Hall, New Delhi, 2011
9. Narayana Pillai,N. Principles of Fluid Mechanics and Fluid Machines, University Press, 2011.
10. Kumar.D.N. Fluid Mechanics and Fluid power Engineering, S.K.Kataria & sons, 2013.

**Course Code: CET203**  
**Fluid Mechanics and Hydraulics**  
**Course content and Schedule of lecture (sample)**

Module	Topic	Course outcome addressed	No of Hours
<b>Module I (9 Hours)</b>			
1.1	Introduction to the subject-Fluid properties (mass density, specific weight, viscosity, specific gravity) Classification of Fluids	CO1	1
1.2	Fluid statics-fluid pressure and variation of pressure in a fluid, Pressure head	CO1	1
1.3	Measurement of pressure using piezometers and manometers	CO3	1
1.4	Problems on pressure measurement	CO3	1
1.5	Tutorial	CO3	1
1.6	Pressure head on immersed plane- vertical and inclined cases	CO3	1
1.7	Problems on estimation of pressure	CO3	1
1.8	Estimation of pressure force acting on curved surfaces	CO1	1
1.9	Tutorial	CO3	1
<b>Module II (9 Hours)</b>			
2.1	Buoyancy, buoyant force, principle of floatation, stability of submerged bodies	CO1	1
2.2	Stability of floating bodies, metacentre and metacentric height-analytical determination	CO1	1
2.3	Metacentric height- experimental determination, problems	CO3	1
2.4	Problems on buoyancy and floatation	CO3	1

2.5	Kinematics of fluids: Methods of describing fluid motion, Lagrangian and Eulerian methods, Types of fluid flow; Description of fluid motion-streamline, streakline and pathline	CO2	1
2.6	Velocity & Acceleration of fluid particle, convective and local acceleration	CO2	1
2.7	Problems on flow properties	CO2	1
2.8	Conservation of mass, Equation of continuity in 1D,2D and 3D	CO2	1
2.9	Tutorial	CO2	1
<b>Module III (9 Hours)</b>			
3.1	Introduction to fluid kinetics – forces acting; Euler’s equation of motion and integration of Euler’s equation of motion along a streamline- Bernoulli’s Equation, Energy correction factor	CO1	1
3.2	Applications of Bernoulli’s equation, Venturimeter and orifice meter, Problems	CO4	1
3.3	Problems	CO4	1
3.4	Flow through orifices: types of orifices, Experimental determination of Hydraulic coefficients	CO2	1
3.5	Flow over a sharp edged orifice, Flow through large rectangular orifice and submerged orifices	CO2	1
3.6	Pipe flow: Equations for determination of major and minor energy losses	CO1	1
3.7	Hydraulic gradient and total energy line; pipes in series and parallel	CO1	1
3.8,	Problems on discharge computation	CO4	1
3.9	Tutorial	CO4	1
<b>Module IV (9 Hours)</b>			
4.1	Introduction-difference between pipe flow and open channel flow- types of channels and flow, velocity distribution in open channels	CO1	1
4.2	Geometric elements of channels-computation for simple sections- Uniform flow; Derivation of Chezy’s equation	CO1	1
4.3	Manning’s and Kutter’s Equation, Concept of Conveyance and Section factor, problems	CO5	1
4.4	Problems		1
4.5	Most economical sections-conditions for rectangular, triangular and trapezoidal channels	CO5	1
4.6	Most economical circular channels, Problems	CO5	1
4.7	Flow measurement in channels- Types of weirs flow over rectangular and triangular sharp crested weir; Effect of end contraction and velocity of approach	CO5	1



4.8	Flow over a trapezoidal weir, Cipolletti weir, broad crested weir, submerged weirs	CO5	1
4.9	Tutorial	CO5	1
<b>Module V (9 Hours)</b>			
5.1	Specific energy, Specific energy diagram computation of critical depth	CO5	1
5.2	Problems	CO5	1
5.3	Gradually varied flow-Concept, Forms of GVF equations,	CO5	1
5.4	Types and Characteristics of water surface profiles	CO5	1
5.5	Problems	CO5	1
5.6	Computation of length of water surface profiles by direct step method, Problems	CO5	1
5.7	Specific force, Conjugate depths, Hydraulic jump- Derivation of sequent depth relation in rectangular channels	CO5	1
5.8	Characteristics, types and uses of hydraulic jump, Problems	CO5	1
5.9	Tutorial	CO5	1

CET205	SURVEYING & GEOMATICS	CATEGORY	L	T	P	CREDIT	YEAR OF INTRODUCTION
		PCC	4	0	0	4	2019

**Preamble:**

Objective of the course is to impart an awareness on the principles of surveying, various methods and instruments of surveying, errors associated with field measurements and advanced surveying techniques.

**Prerequisite:** Nil

**Course Outcomes:** After the completion of the course, the student will be able to:

CO 1	Apply surveying techniques and principles of leveling for the preparation of contour maps, computation of area-volume and sketching mass diagram
CO 2	Apply the principles of surveying for triangulation
CO 3	Apply different methods of traverse surveying and traverse balancing
CO 4	Identify the possible errors in surveying and apply the corrections in field measurements
CO 5	Apply the basic knowledge of setting out of different types of curves
CO 6	Employ surveying techniques using advanced surveying equipments

**Mapping of course outcomes with program outcomes**

	PO 1	PO 2	PO 3	PO 4	PO 5	PO 6	PO 7	PO 8	PO 9	PO 10	PO 11	PO 12
CO 1	3	3		2	2							
CO 2	3	3		2								
CO 3	3	3						1	2			
CO 4	3	2										
CO 5	3	2	1	1				1	2			
CO 6	3			2	2			1				2

**Assessment Pattern**

Bloom's Category	Continuous Assessment		End Semester Examination (marks)
	Test 1 Marks	Test 2 Marks	
Remember	7.5	7.5	30
Understand	7.5	7.5	30
Apply	10	10	40
Analyse			
Evaluate			
Create			

**Mark Distribution**

<b>Total Marks</b>	<b>CIE (Marks)</b>	<b>ESE (Marks)</b>	<b>ESE Duration</b>
150	50	100	3 hours

**Continuous Internal Evaluation Pattern:**

Attendance	: 10 marks
Continuous Assessment Test (2 numbers)	: 25 marks
Assignment/Quiz/Course Project	: 15 marks

**End Semester Examination Pattern:**

The question consists of two parts- Part A and Part B. Part A consists of 10 questions with 3 marks for each (two questions from each module). Part B consists of two questions from each module, out of which one has to be answered. Each question carries 14 marks and can have maximum 2 subdivisions.

**Sample Course Level Assessment Questions:**

**Course Outcome 1 (CO1):** The following perpendicular offsets were taken at 10m intervals from a survey line AB to an irregular boundary line: 2.50, 3.80, 4.33, 6.76, 5.30, 7.25, 8.95, 8.25 and 5.50. Calculate the area in sqm, enclosed between the survey line, the irregular boundary, the first and the last offsets by i) Simpsons rule ii) Trapezoidal rule.

**Course Outcome 2 (CO2):** What is meant by satellite station and reduction to centre. From an eccentric station S, 13 metres to the west of the main station B, the following angles were measured. Angle BSC =  $75^{\circ}25'32''$ , Angle CSA =  $55^{\circ}32'20''$ . The stations S and C are to the opposite sides of the line AB. Calculate the correct angle ABC if the lengths AB and BC are 5288m and 4940m respectively

**Course Outcome 3 (CO3):** How do you balance a closed traverse with closing error using the graphical method of Bowditch's rule?

**Course Outcome 4 (CO4):** How is the most probable value in direct observations of equal weights determined?

**Course Outcome 5 (CO5):** How do you set out a simple curve by Rankine's method of tangential angles. Calculate the necessary data for setting out a curve of 300 m radius. Assume any other data, if required.

**Course Outcome 6 (CO6):** What are spectral signature curves? Discuss the spectral reflectance of soil, water and vegetation.

## Syllabus

### Module 1

**Introduction to Surveying-** Principles, Linear, angular and graphical methods, Survey stations, Survey lines- ranging, Bearing of survey lines, Local attraction, Declination, Methods of orientation ( by compass and by backsighting)

**Levelling:** Principles of levelling- Dumpy level, booking and reducing levels, Methods- simple, differential, reciprocal leveling, profile levelling and cross sectioning. Digital and Auto Level, Errors in leveling

**Contouring:** Characteristics, methods, uses.

### Module 2

**Area and Volume:** computation of area by offsets to base line, by dividing area into number of triangles; volume of level section by prismoidal and trapezoidal formulae.

**Mass diagram:** Construction, Characteristics and uses

**Theodolite survey:** Instruments, Measurement of horizontal and vertical angle, principles of stadia and tangential tacheometry (introduction only)

**Triangulation:** Triangulation figures, Triangulation stations, Inter visibility of stations, Satellite Stations and reduction to centre.

### Module 3

**Traverse Surveying** - Methods of traversing, Checks in closed traverse, Traverse computations, Balancing the traverse- Bowditch's rule, Transit rule, graphical method based on Bowditch's rule, omitted measurements (a line and an angle only)

**Theory of Errors** – Types, theory of least squares, Weighting of observations, Most probable value, Computation of indirectly observed quantities - method of normal equations.

### Module 4

**Curve Surveying** – Elements of simple and compound curves – Methods of setting out (Angular methods only)– Elements of Reverse curve (Introduction only)– Transition curve – length of curve – Elements of transition curve - Vertical curve (Introduction only)

**Total Station** – concept of EDM, principles and working, advantages and applications

## Module 5

**Global Positioning Systems**-Components and principles, satellite ranging-calculating position, signal structure, application of GPS, GPS Surveying methods-Static, Rapid static, Kinematic methods – DGPS

**Remote Sensing** : Definition- Electromagnetic spectrum-Energy interactions with atmosphere and earth surface features-spectral reflectance of vegetation, soil and water- Classification of sensors- Active and Passive, Resolution-spatial, spectral radiometric and Temporal resolution, Multi spectral scanning-Along track and across track scanning

**Geographical Information System**-components of GIS, GIS operations, Map projections-methods, Coordinate systems-Geographic and Projected coordinate systems, Data Types- Spatial and attribute data, Raster and vector data representation

### Text Books :

1. Dr. B.C. Punmia , Ashok Kumar Jain & Arun Kumar Jain - Surveying , Laxmi publications (P) Ltd , 2005
2. Chang,K , “Introduction to Geographic Information Systems”, Tata McGraw-Hill Publishing Co. Ltd, 2008
3. George Joseph, “Fundamentals of Remote Sensing”, University Press, 2003

### References :

1. C. Venkatramaiah, Textbook of Surveying, Universities Press (India) Private Limited 2011
2. James M Andersen, Edward M Mikhail, Surveying Theory and Practice, McGraw Hill Education
4. Prof. T.P.Kenetkar&Prof.S.V.Kulkarni - Surveying and Levelling , Pune VidyarthiGriha Prakashan,2004
5. N NBasak, Surveying and Levelling, McGrawHill Education
6. R.Agor - A Text book of Surveying and Levelling, Khanna Publishers, 2005
3. S.K.Duggal - Surveying Vol. I, Tata McGraw Hill Ltd ,Reprint 2015.
7. S.K. Duggal - Surveying Vol. II, Tata McGraw Hill Ltd ,Reprint 2015
4. Burrough P , Principles of Geographical Information systems, Oxford University Press, 1998
5. Iliffe, C.J., Datums and Map Projections for Remote Sensing, GIS and Surveying, Whittles Publishing, 2006
6. James M Andersen, Edward M Mikhail, Surveying Theory and Practice, McGraw Hill education, 7e, 1998
7. Kang-tsung Chang, „Introduction to GIS“ , Tata McGraw-Hill Publishing Co. Ltd, 8e, 2016
8. Lillesand M and Kiefer W, “Remote Sensing and Image Interpretation”. John Wiley and Sons,Inc., 2000

**Course Content and lecture Schedule:**

No.	Topic	Course Outcome	No. of Hrs
1	<b>Module 1</b>		Total: 9
1.1	<b>Introduction to Surveying-</b> Principles, Linear, angular and graphical methods, Survey stations, Survey lines- ranging, Bearing of survey lines, Local attraction, Declination, Methods of orientation	CO1	4
1.2	<b>Levelling:</b> Principles of levelling- Dumpy level, booking and reducing levels, Methods- simple, differential, reciprocal leveling, profile levelling and cross sectioning. Digital and Auto Level, Errors in leveling	CO1	4
1.3	<b>Contouring:</b> Characteristics, methods, uses.	CO1	1
2	<b>Module 2</b>		Total: 9
2.1	<b>Area and Volume:</b> computation of area by offsets to base line, by dividing area into number of triangles; volume of level section by prismoidal and trapezoidal formulae.	CO1	3
2.2	<b>Mass diagram:</b> Construction, Characteristics and uses	CO1	1
2.3	<b>Theodolite survey:</b> Instruments, Measurement of horizontal and vertical angle, principles of stadia and tangential tacheometry (introduction only)	CO2	2
2.4	<b>Triangulation:</b> Triangulation figures, Triangulation stations, Inter visibility of stations, Satellite Stations and reduction to centre.	CO2	3
3	<b>Module 3</b>		Total: 9
3.1	<b>Traverse Surveying</b> - Methods of traversing, Checks in closed traverse, Traverse computations, Balancing the traverse- Bowditch's rule, Transit rule, graphical method based on Bowditch's rule, Gales Traverse table, omitted measurements (a line and an angle only)	CO3	5
3.2	<b>Theory of Errors</b> – Types, theory of least squares, Weighting of observations, Most probable value, Computation of indirectly observed quantities - method of normal equations.	CO4	4
4	<b>Module 4</b>		Total: 9
4.1	<b>Curve Surveying</b> – Elements of simple and compound curves – Methods of setting out (Angular methods only)– Elements of Reverse curve (Introduction only)– Transition curve – length of curve – Elements of transition curve - Vertical curve (introduction only)	CO5	6
4.2	<b>Total Station</b> – concept of EDM, principles and working, advantages and applications	CO6	3
5	<b>Module 5</b>		Total: 9
5.1	<b>Global Positioning Systems-</b> Components and Principles, Satellite ranging-calculating position, signal structure,	CO6	3

	application of GPS, GPS Surveying methods-Static, Rapid static , Kinematic methods – DGPS		
5.2	<b>Remote Sensing</b> : Definition- Electromagnetic spectrum- Energy interactions with atmosphere and earth surface features- spectral reflectance of vegetation, soil and water- Classification of sensors- Active and Passive, Resolution-spatial, spectral radiometric and Temporal resolution, Multi spectral scanning- Along track and across track scanning	CO6	3
5.3	<b>Geographical Information System</b> -components of GIS, GIS operations, Map projections- methods, Coordinate systems- Geographic and Projected coordinate systems, Data Types- Spatial and attribute data, Raster and vector data representation	CO6	3

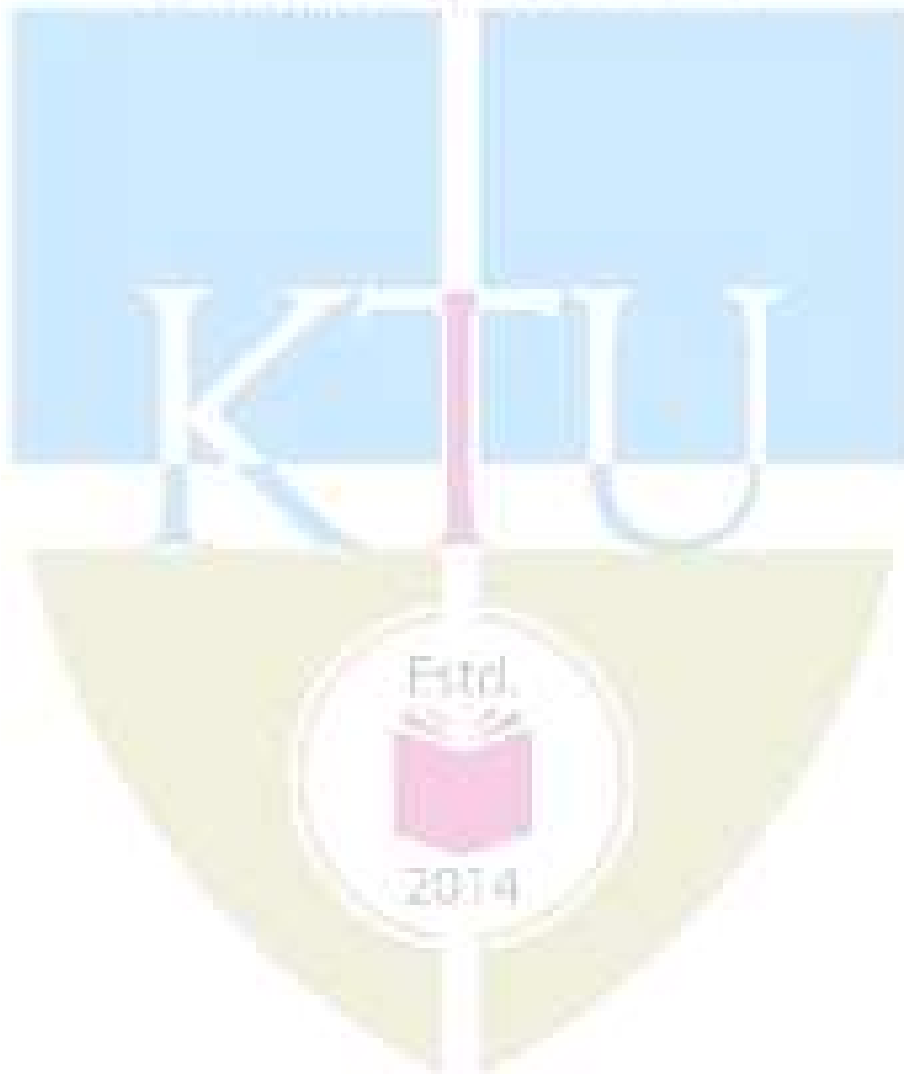

**APJ ABDUL KALAM TECHNOLOGICAL UNIVERSITY  
THIRD SEMESTER B. TECH DEGREE EXAMINATION, MONTH & YEAR**

Course Code: **CET 205**

Course Name: **SURVEYING & GEOMATICS**  
**Model Question Paper**

Marks: 100

Duration: 3 hrs

**PART A**

**(Answer all Questions: Each question carries 3 marks)**

1. What are the general principles of surveying?
2. Define back sight, foresight and intermediate sight.
3. How do you determine the intervisibility of triangulation stations?
4. What is the principle of stadia tacheometry?
5. How will you determine probable error of computed quantities?
6. What are the checks in closed traverse?
7. What are the elements of a compound curve?
8. Explain the two theodolite method of setting out of simple curve.
9. What is multi spectral scanning? Differentiate along track and across track scanning.
10. What is meant by satellite ranging?

**PART B**

**(Answer one full question from each module)**

11. a. Define contour. What are the characteristics of contour? (4)
- b. The following readings were taken in a running closed compass traverse.  
Line FB BB  
AB  $49^{\circ}55' 230^{\circ}00'$   
BC  $177^{\circ}45' 356^{\circ}00'$   
CD  $104^{\circ}15' 284^{\circ}55'$   
DE  $165^{\circ}15' 345^{\circ}15'$   
EA  $259^{\circ}30' 79^{\circ}90'$ 
  - i) State the stations which were affected by local attraction.
  - ii) Determine the corrected bearings
  - iii) Calculate the true bearings if the declination was  $1^{\circ} 30' W$ . (10)

**OR**

12. a. What are the different methods of orientation in plane table surveying? (4)



- b. The following readings were taken with a dumpy level and a 4 m levelling staff on a continuously sloping ground at 30m intervals. 0.685, 1.455, 1.850, 2.330, 2.885, 3.380, 1.055, 1.860, 2.265, 3.540, 0.835, 0.945, 1.530 and 2.250. The reduced level of the first point is 80.750. Rule out a page of a level book and enter the above readings. Determine RLs of all points using height of instrument method. Determine the gradient of the line joining the first and last point. (10)
13. a. The following perpendicular offsets were taken at 10m intervals from a survey line AB to an irregular boundary line: 2.50, 3.80, 4.33, 6.76, 5.30, 7.25, 8.95, 8.25 and 5.50. Calculate the area in sqm, enclosed between the survey line, the irregular boundary, the first and the last offsets by i) Simpsons rule ii) Trapezoidal rule. (10)
- b. Explain Mass diagram and its characteristics features. (4)

**OR**

14. a. Explain the method of observing the horizontal angle by the method of repetition and reiteration in triangulation survey. (4)
- b. What is meant by satellite station and reduction to centre. From an eccentric station S, 13 metres to the west of the main station B, the following angles were measured. Angle BSC =  $75^{\circ}25'32''$ , Angle CSA =  $55^{\circ}32'20''$ . The stations S and C are to the opposite sides of the line AB. Calculate the correct angle ABC if the lengths AB and BC are 5288m and 4940m respectively. (10)
15. a. The following are the mean values observed in the measurement of three angles A, B, C at one station  
 A =  $86^{\circ}42'46.2''$  with weight 4  
 A+B =  $134^{\circ}36'33.6''$  with weight 3  
 A+B+C =  $262^{\circ}18'10.4''$  with weight 1  
 B+C =  $185^{\circ}35'24.8''$  with weight 2  
 Calculate the most probable value of A, B and C. (10)
- b. Distinguish between a) closed traverse and open traverse b) loose needle method and fast needle method of traverse surveying (4)

**OR**

16. a. State the fundamental principle of method of least squares. How is the most probable value in direct observations of equal weights determined? (7)
- b. Describe the procedures for balancing a closed traverse by graphical method. (7)
17. a. Two tangents intersect at chainage 1000 m, the deflection angle being  $60^{\circ}20'$ . Calculate the necessary data for setting out a curve of 200 m radius to connect two tangents if it is intended to set out the curve by Rankine's method of tangential angles. Take peg interval equal to 20 m. (10)

b. What are the advantages and applications of Total Station survey?(4)

**OR**

18. a. What is transition curve? What are its functions? What are the methods to find out the length of transition curve? (10)

19. b. Explain the principle behind electro magnetic distance measurement. (4)

20. a. What are the components of GPS? Illustrate with figure. Explain the functions of each of them in detail. (10)

b. What are the applications of GIS? (4)

**OR**

21. a. How does electro magnetic radiation interact with atmosphere? (7)

b. What are the various types of map projections based on the projection surface? (7)

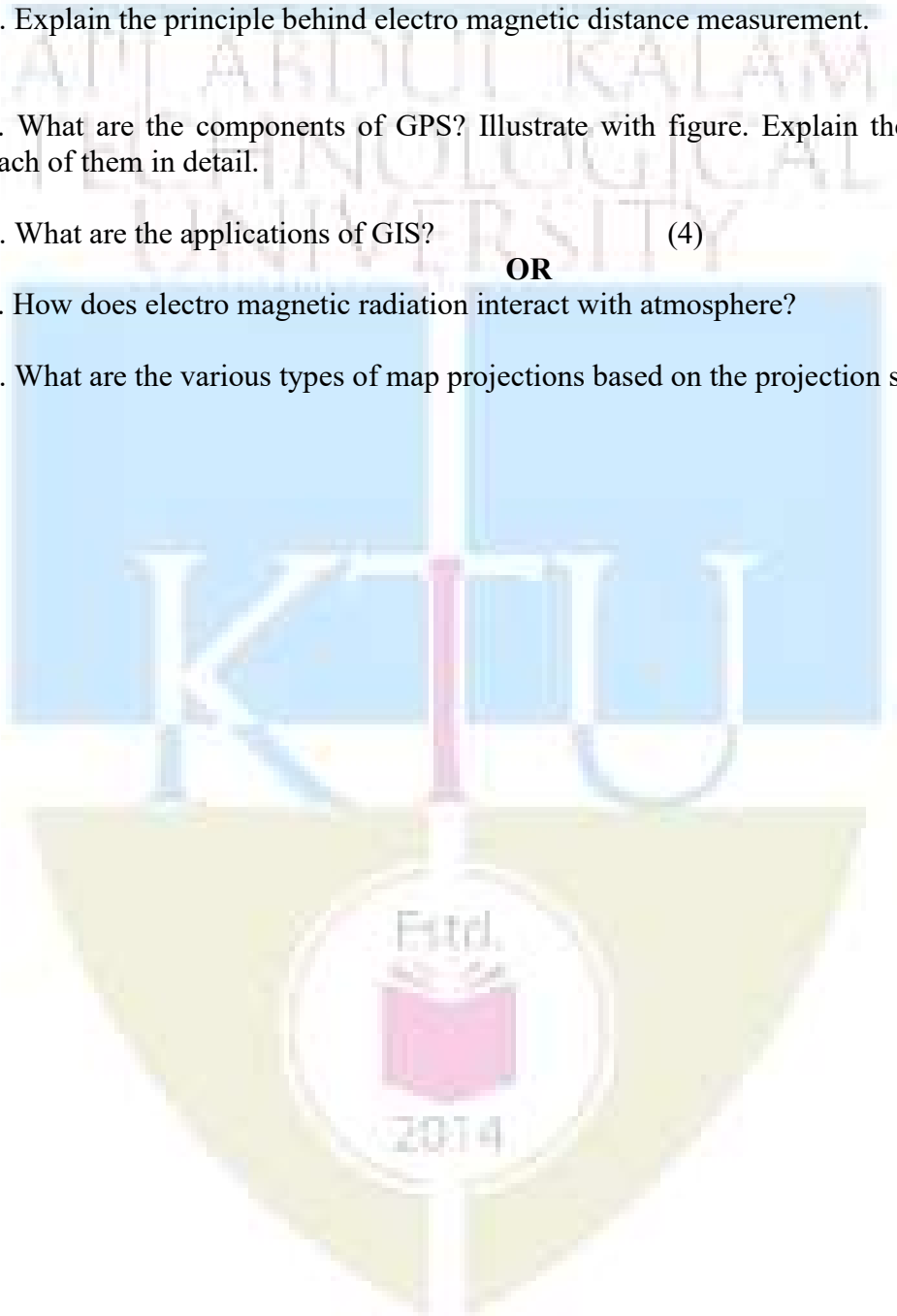

CODE	COURSE NAME	CATEGORY	L	T	P	CREDIT
					2	0
<b>EST 200</b>	<b>DESIGN AND ENGINEERING</b>					

**Preamble:**

The purpose of this course is to

- i) introduce the undergraduate engineering students the fundamental principles of design engineering,
- ii) make them understand the steps involved in the design process and
- iii) familiarize them with the basic tools used and approaches in design.

Students are expected to apply design thinking in learning as well as while practicing engineering, which is very important and relevant for today. Case studies from various practical situations will help the students realize that design is not only concerned about the function but also many other factors like customer requirements, economics, reliability, etc. along with a variety of life cycle issues.

The course will help students to consider aesthetics, ergonomics and sustainability factors in designs and also to practice professional ethics while designing.

**Prerequisite:**

**Nil.** The course will be generic to all engineering disciplines and will not require specialized preparation or prerequisites in any of the individual engineering disciplines.

**Course Outcomes:**

After the completion of the course the student will be able to

<b>CO 1</b>	Explain the different concepts and principles involved in design engineering.
<b>CO 2</b>	Apply design thinking while learning and practicing engineering.
<b>CO 3</b>	Develop innovative, reliable, sustainable and economically viable designs incorporating knowledge in engineering.

**Mapping of course outcomes with program outcomes**

	PO 1	PO 2	PO 3	PO 4	PO 5	PO 6	PO 7	PO 8	PO 9	PO 10	PO 11	PO 12
<b>CO 1</b>	2	1					1			1		
<b>CO 2</b>		2				1		1				2
<b>CO 3</b>			2			1	1		2	2		1

**Assessment Pattern****Continuous Internal Evaluation (CIE) Pattern:**

Attendance	: 10 marks
Continuous Assessment Test (2 numbers)	: 25 marks
Assignment/Quiz/Course project	: 15 marks

**End Semester Examination (ESE) Pattern:** There will be two parts; Part A and Part B.

Part A : 30 marks

part B : 70 marks

Part A contains 10 questions with 2 questions from each module, having 3 marks for each question. Students should answer all questions.

Part B contains 2 case study questions from each module of which student should answer any one. Each question carry 14 marks and can have maximum 2 sub questions.

**Mark distribution**

Total Marks	CIE	ESE	ESE Duration
150	50	100	3 hours

Bloom's Category	Continuous Assessment Tests		End Semester Examination
	1	2	
Remember	5	5	10
Understand	10	10	20
Apply	35	35	70
Analyse	-	-	-
Evaluate	-	-	-
Create	-	-	-

**Course Level Assessment Questions**

**Course Outcome 1 (CO1): Appreciate the different concepts and principles involved in design engineering.**

1. State how engineering design is different from other kinds of design
2. List the different stages in a design process.
3. Describe design thinking.
4. State the function of prototyping and proofing in engineering design.
5. Write notes on the following concepts in connection with design engineering 1) Modular Design, 2) Life Cycle Design, 3) Value Engineering, 4) Concurrent Engineering, and 5) Reverse Engineering
6. State design rights.

**Course Outcome 2 (CO2) Apply design thinking while learning and practicing engineering.**

1. Construct the iterative process for design thinking in developing simple products like a pen, umbrella, bag, etc.
2. Show with an example how divergent-convergent thinking helps in generating alternative designs and then how to narrow down to the best design.
3. Describe how a problem-based learning helps in creating better design engineering solutions.
4. Discuss as an engineer, how ethics play a decisive role in your designs

**Course Outcome 3 (CO3): Develop innovative, reliable, sustainable and economically viable designs incorporating different segments of knowledge in engineering.**

1. Illustrate the development of any simple product by passing through the different stages of design process
2. Show the graphical design communication with the help of detailed 2D or 3D drawings for any simple product.
3. Describe how to develop new designs for simple products through bio-mimicry.

**Model Question paper**

Page 1 of 2

Reg No.: \_\_\_\_\_ Name: \_\_\_\_\_

**APJ ABDUL KALAM TECHNOLOGICAL UNIVERSITY****THIRD/FOURTH SEMESTER B.TECH DEGREE EXAMINATION****Course Code: EST 200****Course Name: DESIGN AND ENGINEERING****Max. Marks: 100 Duration: 3 Hours****PART A****Answer all questions, each question carries 3 marks****Use only hand sketches**

- (1) Write about the basic design process.
- (2) Describe how to finalize the design objectives.
- (3) State the role of divergent-convergent questioning in design thinking.
- (4) Discuss how to perform design thinking in a team managing the conflicts.
- (5) Show how engineering sketches and drawings convey designs.
- (6) Explain the role of mathematics and physics in design engineering process.
- (7) Distinguish between project-based learning and problem-based learning in design engineering.
- (8) Describe how concepts like value engineering, concurrent engineering and reverse engineering influence engineering designs?
- (9) Show how designs are varied based on the aspects of production methods, life span, reliability and environment?
- (10) Explain how economics influence the engineering designs?

**(10x3 marks =30 marks)****Part B****Answer any ONE question from each module. Each question carry 14 marks****Module 1**

- (11) Show the designing of a wrist watch going through the various stages of the design process. Use hand sketches to illustrate the processes.
- or**
- (12) Find the customer requirements for designing a new car showroom. Show how the design objectives were finalized considering the design constraints?

**Module 2**

(13) Illustrate the design thinking approach for designing a bag for college students within a limited budget. Describe each stage of the process and the iterative procedure involved. Use hand sketches to support your arguments.

or

(14) Construct a number of possible designs and then refine them to narrow down to the best design for a drug trolley used in hospitals. Show how the divergent-convergent thinking helps in the process. Provide your rationale for each step by using hand sketches only.

**Module 3**

(15) Graphically communicate the design of a thermo flask used to keep hot coffee. Draw the detailed 2D drawings of the same with design detailing, material selection, scale drawings, dimensions, tolerances, etc. Use only hand sketches.

or

(16) Describe the role of mathematical modelling in design engineering. Show how mathematics and physics play a role in designing a lifting mechanism to raise 100 kg of weight to a floor at a height of 10 meters in a construction site.

**Module 4**

(17) Show the development of a nature inspired design for a solar powered bus waiting shed beside a highway. Relate between natural and man-made designs. Use hand sketches to support your arguments.

or

(18) Show the design of a simple sofa and then depict how the design changes when considering 1) aesthetics and 2) ergonomics into consideration. Give hand sketches and explanations to justify the changes in designs.

**Module 5**

(19) Examine the changes in the design of a foot wear with constraints of 1) production methods, 2) life span requirement, 3) reliability issues and 4) environmental factors. Use hand sketches and give proper rationalization for the changes in design.

or

(20) Describe how to estimate the cost of a particular design using ANY of the following:  
i) a website, ii) the layout of a plant, iii) the elevation of a building, iv) an electrical or electronic system or device and v) a car.

Show how economics will influence the engineering designs. Use hand sketches to support your arguments.

**(5x14 marks =70 marks)**

## Syllabus

### Module 1

Design Process:- Introduction to Design and Engineering Design, Defining a Design Process:-Detailing Customer Requirements, Setting Design Objectives, Identifying Constraints, Establishing Functions, Generating Design Alternatives and Choosing a Design.

### Module 2

Design Thinking Approach:-Introduction to Design Thinking, Iterative Design Thinking Process Stages: Empathize, Define, Ideate, Prototype and Test. Design Thinking as Divergent-Convergent Questioning. Design Thinking in a Team Environment.

### Module 3

Design Communication (Languages of Engineering Design):-Communicating Designs Graphically, Communicating Designs Orally and in Writing. Mathematical Modeling In Design, Prototyping and Proofing the Design.

### Module 4

Design Engineering Concepts:-Project-based Learning and Problem-based Learning in Design.Modular Design and Life Cycle Design Approaches. Application of Biomimicry,Aesthetics and Ergonomics in Design. Value Engineering, Concurrent Engineering, and Reverse Engineering in Design.

### Module 5

Expediency, Economics and Environment in Design Engineering:-Design for Production, Use, and Sustainability. Engineering Economics in Design. Design Rights. Ethics in Design

### Text Books

- 1) YousefHaik, SangarappillaiSivaloganathan, Tamer M. Shahin, Engineering Design Process, Cengage Learning 2003, Third Edition, ISBN-10: 9781305253285,
- 2) Voland, G., Engineering by Design, Pearson India 2014, Second Edition, ISBN 9332535051

### Reference Books

- 1.Philip Kosky, Robert Balmer, William Keat, George Wise, Exploring Engineering, Fourth Edition: An Introduction to Engineering and Design, Academic Press 2015, 4th Edition, ISBN: 9780128012420.
2. Clive L. Dym, Engineering Design: A Project-Based Introduction, John Wiley & Sons, New York 2009, Fourth Edition, ISBN: 978-1-118-32458-5
3. Nigel Cross, Design Thinking: Understanding How Designers Think and Work, Berg Publishers 2011, First Edition, ISBN: 978-1847886361
4. Pahl, G., Beitz, W., Feldhusen, J., Grote, K.-H., Engineering Design: A Systematic Approach, Springer 2007, Third Edition, ISBN 978-1-84628-319-2



## Course Contents and Lecture Schedule

No	Topic	No. of Lectures
1	<b><u>Module 1: Design Process</u></b>	
1.1	Introduction to Design and Engineering Design. <i>What does it mean to design something? How Is engineering design different from other kinds of design? Where and when do engineers design? What are the basic vocabulary in engineering design? How to learn and do engineering design.</i>	1
1.2	<i>Defining a Design Process-: Detailing Customer Requirements.</i> <i>How to do engineering design? Illustrate the process with an example. How to identify the customer requirements of design?</i>	1
1.3	<i>Defining a Design Process-: Setting Design Objectives, Identifying Constraints, Establishing Functions.</i> <i>How to finalize the design objectives? How to identify the design constraints? How to express the functions a design in engineering terms?</i>	1
1.4	<i>Defining a Design Process-: Generating Design Alternatives and Choosing a Design.</i> <i>How to generate or create feasible design alternatives? How to identify the "best possible design"?</i>	1
1.5	Case Studies:- Stages of Design Process. <i>Conduct exercises for designing simple products going through the different stages of design process.</i>	1
2	<b><u>Module 2: Design Thinking Approach</u></b>	
2.1	Introduction to Design Thinking <i>How does the design thinking approach help engineers in creating innovative and efficient designs?</i>	1
2.2	Iterative Design Thinking Process Stages: Empathize, Define, Ideate, Prototype and Test. <i>How can the engineers arrive at better designs utilizing the iterative design thinking process (in which knowledge acquired in the later stages can be applied back to the earlier stages)?</i>	1
2.3	Design Thinking as Divergent-Convergent Questioning. <i>Describe how to create a number of possible designs and then how to refine and narrow down to the 'best design'.</i>	1
2.4	Design Thinking in a Team Environment. <i>How to perform design thinking as a team managing the conflicts ?</i>	1
2.5	Case Studies: Design Thinking Approach. <i>Conduct exercises using the design thinking approach for</i>	1

	<i>designing any simple products within a limited time and budget</i>	
<b>3</b>	<b><u>Module 3: Design Communication (Languages of Engineering Design)</u></b>	
3.1	Communicating Designs Graphically. <i>How do engineering sketches and drawings convey designs?</i>	1
3.2	Communicating Designs Orally and in Writing. <i>How can a design be communicated through oral presentation or technical reports efficiently?</i>	1
<b>First Series Examination</b>		
3.3	Mathematical Modelling in Design. <i>How do mathematics and physics become a part of the design process?</i>	1
3.4	Prototyping and Proofing the Design. <i>How to predict whether the design will function well or not?</i>	1
3.5	Case Studies: Communicating Designs Graphically. <i>Conduct exercises for design communication through detailed 2D or 3D drawings of simple products with design detailing, material selection, scale drawings, dimensions, tolerances, etc.</i>	1
<b>4</b>	<b><u>Module 4: Design Engineering Concepts</u></b>	
4.1	Project-based Learning and Problem-based Learning in Design. <i>How engineering students can learn design engineering through projects?</i> <i>How students can take up problems to learn design engineering?</i>	1
4.2	Modular Design and Life Cycle Design Approaches. <i>What is modular approach in design engineering? How it helps?</i> <i>How the life cycle design approach influences design decisions?</i>	1
4.3	Application of Bio-mimicry, Aesthetics and Ergonomics in Design. <i>How do aesthetics and ergonomics change engineering designs?</i> <i>How do the intelligence in nature inspire engineering designs? What are the common examples of bio-mimicry in engineering?</i>	1
4.4	Value Engineering, Concurrent Engineering, and Reverse Engineering in Design. <i>How do concepts like value engineering , concurrent engineering and reverse engineering influence engineering designs?</i>	1
4.5	Case Studies: Bio-mimicry based Designs. <i>Conduct exercises to develop new designs for simple</i>	1

	<i>products using bio-mimicry and train students to bring out new nature inspired designs.</i>	
5	<b><u>Module 5: Expediency, Economics and Environment in Design Engineering</u></b>	
5.1	Design for Production, Use, and Sustainability. <i>How designs are finalized based on the aspects of production methods, life span, reliability and environment?</i>	1
5.2	Engineering Economics in Design. <i>How to estimate the cost of a particular design and how will economics influence the engineering designs?</i>	1
5.3	Design Rights. <i>What are design rights and how can an engineer put it into practice?</i>	1
5.4	Ethics in Design. <i>How do ethics play a decisive role in engineering design?</i>	1
5.5	Case Studies: Design for Production, Use, and Sustainability. <i>Conduct exercises using simple products to show how designs change with constraints of production methods, life span requirement, reliability issues and environmental factors.</i>	1
<b>Second Series Examination</b>		



Code.	Course Name	L	T	P	Hrs	Credit
HUT 200	Professional Ethics	2	0	0	2	2

**Preamble:** To enable students to create awareness on ethics and human values.

**Prerequisite:** Nil

**Course Outcomes:** After the completion of the course the student will be able to

CO 1	Understand the core values that shape the ethical behaviour of a professional.
CO 2	Adopt a good character and follow an ethical life.
CO 3	Explain the role and responsibility in technological development by keeping personal ethics and legal ethics.
CO 4	Solve moral and ethical problems through exploration and assessment by established experiments.
CO 5	Apply the knowledge of human values and social values to contemporary ethical values and global issues.

#### Mapping of course outcomes with program outcomes

	PO 1	PO 2	PO 3	PO 4	PO 5	PO 6	PO 7	PO 8	PO 9	PO1 0	PO1 1	PO1 2
CO 1								2			2	
CO 2								2			2	
CO 3								3			2	
CO 4								3			2	
CO 5								3			2	

#### Assessment Pattern

Bloom's category	Continuous Assessment Tests		End Semester Exam
	1	2	
Remember	15	15	30
Understood	20	20	40
Apply	15	15	30

#### Mark distribution

Total Marks	CIE	ESE	ESE Duration
150	50	100	3 hours

**Continuous Internal Evaluation Pattern:**

Attendance	: 10 marks
Continuous Assessment Tests (2 Nos)	: 25 marks
Assignments/Quiz	: 15 marks

**End Semester Examination Pattern:** There will be two parts; Part A and Part B. Part A contains 10 questions with 2 questions from each module, having 3 marks for each question. Students should answer all questions. Part B contains 2 questions from each module of which student should answer any one. Each question can have maximum 2 sub-divisions and carry 14 marks.

**Course Level Assessment Questions****Course Outcome 1 (CO1):**

1. Define integrity and point out ethical values.
2. Describe the qualities required to live a peaceful life.
3. Explain the role of engineers in modern society.

**Course Outcome 2 (CO2)**

1. Derive the codes of ethics.
2. Differentiate consensus and controversy.
3. Discuss in detail about character and confidence.

**Course Outcome 3(CO3):**

1. Explain the role of professional's ethics in technological development.
2. Distinguish between self interest and conflicts of interest.
3. Review on industrial standards and legal ethics.

**Course Outcome 4 (CO4):**

1. Illustrate the role of engineers as experimenters.
2. Interpret the terms safety and risk.
3. Show how the occupational crimes are resolved by keeping the rights of employees.

**Course Outcome 5 (CO5):**

1. Exemplify the engineers as managers.
2. Investigate the causes and effects of acid rain with a case study.
3. Explore the need of environmental ethics in technological development.

**Model Question paper**

QP CODE:

Reg No: \_\_\_\_\_

PAGES:3

Name : \_\_\_\_\_

**APJ ABDUL KALAM TECHNOLOGICAL UNIVERSITY THIRD/FOURTH SEMESTER  
B.TECH DEGREE EXAMINATION, MONTH & YEAR**

Course Code: HUT 200

Course Name: PROFESSIONAL ETHICS

Max. Marks: 100

Duration: 3 Hours

(2019-Scheme)

**PART A****(Answer all questions, each question carries 3 marks)**

1. Define empathy and honesty.
2. Briefly explain about morals, values and ethics.
3. Interpret the two forms of self-respect.
4. List out the models of professional roles.
5. Indicate the advantages of using standards.
6. Point out the conditions required to define a valid consent?
7. Identify the conflicts of interests with an example?
8. Recall confidentiality.
9. Conclude the features of biometric ethics.
10. Name any three professional societies and their role relevant to engineers.

(10x3 = 30 marks)

**PART B****(Answer one full question from each module, each question carries 14 marks)****MODULE I****11. a)** Classify the relationship between ethical values and law?**b)** Compare between caring and sharing.

(10+4 = 14 marks)

**Or****12. a)** Exemplify a comprehensive review about integrity and respect for others.

b) Discuss about co-operation and commitment.

(8+6 = 14 marks)

### MODULE II

13.a) Explain the three main levels of moral developments, devised by Kohlberg.

b) Differentiate moral codes and optimal codes.

(10+4 = 14 marks)

Or

14. a) Extrapolate the duty ethics and right ethics.

b) Discuss in detail the three types of inquiries in engineering ethics

(8+6 = 14 marks)

### MODULE III

15.a) Summarize the following features of morally responsible engineers.

(i) Moral autonomy

(ii) Accountability

b) Explain the rights of employees

(8+6 = 14 marks)

Or

16. a) Explain the reasons for Chernobyl mishap ?

b) Describe the methods to improve collegiality and loyalty.

(8+6 = 14 marks)

### MODULE IV

17.a) Execute collegiality with respect to commitment, respect and connectedness.

b) Identify conflicts of interests with an example.

(8+6 = 14 marks)

Or

18. a) Explain in detail about professional rights and employee rights.

b) Exemplify engineers as managers.

### MODULE V

19.a) Evaluate the technology transfer and appropriate technology.

b) Explain about computer and internet ethics.

(8+6 = 14 marks)

Or

20. a) Investigate the causes and effects of acid rain with a case study.

b) Conclude the features of ecocentric and biocentric ethics.

(8+6 = 14 marks)

## Syllabus

### **Module 1 – Human Values.**

Morals, values and Ethics – Integrity- Academic integrity-Work Ethics- Service Learning- Civic Virtue- Respect for others- Living peacefully- Caring and Sharing- Honestly- courage-Cooperation commitment- Empathy-Self Confidence -Social Expectations.

### **Module 2 - Engineering Ethics & Professionalism.**

Senses of Engineering Ethics - Variety of moral issues- Types of inquiry- Moral dilemmas –Moral Autonomy – Kohlberg’s theory- Gilligan’s theory- Consensus and Controversy-Profession and Professionalism- Models of professional roles-Theories about right action –Self interest-Customs and Religion- Uses of Ethical Theories.

### **Module 3- Engineering as social Experimentation.**

Engineering as Experimentation – Engineers as responsible Experimenters- Codes of Ethics- Plagiarism- A balanced outlook on law - Challenges case study- Bhopal gas tragedy.

### **Module 4- Responsibilities and Rights.**

Collegiality and loyalty – Managing conflict- Respect for authority- Collective bargaining- Confidentiality- Role of confidentiality in moral integrity-Conflicts of interest- Occupational crime- Professional rights- Employee right- IPR Discrimination.

### **Module 5- Global Ethical Issues.**

Multinational Corporations- Environmental Ethics- Business Ethics- Computer Ethics -Role in Technological Development-Engineers as Managers- Consulting Engineers- Engineers as Expert witnesses and advisors-Moral leadership.

### **Text Book**

1. M Govindarajan, S Natarajan and V S Senthil Kumar, Engineering Ethics, PHI Learning Private Ltd, New Delhi,2012.
2. R S Naagarazan, A text book on professional ethics and human values, New age international (P) limited ,New Delhi,2006.

### **Reference Books**

1. Mike W Martin and Roland Schinzinger, Ethics in Engineering,4<sup>th</sup> edition, Tata McGraw Hill Publishing Company Pvt Ltd, New Delhi,2014.
2. Charles D Fleddermann, Engineering Ethics, Pearson Education/ Prentice Hall of India, New Jersey,2004.
3. Charles E Harris, Michael S Protchard and Michael J Rabins, Engineering Ethics- Concepts and cases, Wadsworth Thompson Learning, United states,2005.
4. <http://www.slideword.org/slidestag.aspx/human-values-and-Professional-ethics>.



**Course Contents and Lecture Schedule**

<b>SL.No</b>	<b>Topic</b>	<b>No. of Lectures</b> <b>25</b>
<b>1</b>	<b>Module 1 – Human Values.</b>	
1.1	Morals, values and Ethics, Integrity, Academic Integrity, Work Ethics	1
1.2	Service Learning, Civic Virtue, Respect for others, Living peacefully	1
1.3	Caring and Sharing, Honesty, Courage, Co-operation commitment	2
1.4	Empathy, Self Confidence, Social Expectations	1
<b>2</b>	<b>Module 2- Engineering Ethics &amp; Professionalism.</b>	
2.1	Senses of Engineering Ethics, Variety of moral issues, Types of inquiry	1
2.2	Moral dilemmas, Moral Autonomy, Kohlberg's theory	1
2.3	Gilligan's theory, Consensus and Controversy, Profession & Professionalism, Models of professional roles, Theories about right action	2
2.4	Self interest-Customs and Religion, Uses of Ethical Theories	1
<b>3</b>	<b>Module 3- Engineering as social Experimentation.</b>	
3.1	Engineering as Experimentation, Engineers as responsible Experimenters	1
3.2	Codes of Ethics, Plagiarism, A balanced outlook on law	2
3.3	Challenger case study, Bhopal gas tragedy	2
<b>4</b>	<b>Module 4- Responsibilities and Rights.</b>	
4.1	Collegiality and loyalty, Managing conflict, Respect for authority	1
4.2	Collective bargaining, Confidentiality, Role of confidentiality in moral integrity, Conflicts of interest	2
4.3	Occupational crime, Professional rights, Employee right, IPR Discrimination	2
<b>5</b>	<b>Module 5- Global Ethical Issues.</b>	
5.1	Multinational Corporations, Environmental Ethics, Business Ethics, Computer Ethics	2
5.2	Role in Technological Development, Moral leadership	1
5.3	Engineers as Managers, Consulting Engineers, Engineers as Expert witnesses and advisors	2

<b>CODE</b> MCN201	<b>SUSTAINABLE ENGINEERING</b>	<b>CATEGORY</b>	<b>L</b>	<b>T</b>	<b>P</b>	<b>CREDIT</b>
			2	0	0	NIL

**Preamble:** Objective of this course is to inculcate in students an awareness of environmental issues and the global initiatives towards attaining sustainability. The student should realize the potential of technology in bringing in sustainable practices.

**Prerequisite:** NIL

**Course Outcomes:** After the completion of the course the student will be able to

<b>CO 1</b>	Understand the relevance and the concept of sustainability and the global initiatives in this direction
<b>CO 2</b>	Explain the different types of environmental pollution problems and their sustainable solutions
<b>CO 3</b>	Discuss the environmental regulations and standards
<b>CO 4</b>	Outline the concepts related to conventional and non-conventional energy
<b>CO 5</b>	Demonstrate the broad perspective of sustainable practices by utilizing engineering knowledge and principles

#### Mapping of course outcomes with program outcomes

	PO 1	PO 2	PO 3	PO 4	PO 5	PO 6	PO 7	PO 8	PO 9	PO 10	PO 11	PO 12
CO 1						2	3					2
CO 2						2	3					2
CO 3						2	3					2
CO 4						2	3					2
CO 5						2	3					2

#### Assessment Pattern

#### Mark distribution

Bloom's Category	Continuous Assessment Tests		End Semester Examination
	1	2	
Remember	20	20	40
Understand	20	20	40
Apply	10	10	20
Analyse			
Evaluate			
Create			

#### Continuous Internal Evaluation Pattern:

Attendance : 10 marks  
 Continuous Assessment Test (2 numbers) : 25 marks  
 Assignment/Quiz/Course project : 15 marks

**End Semester Examination Pattern:** There will be two parts; Part A and Part B. Part A contain 10 questions with 2 questions from each module, having 3 marks for each question. Students should answer all questions. Part B contains 2 questions from each module of which student should answer any one. Each question can have maximum 2 sub-divisions and carry 14 marks.

Total Marks	CIE	ESE	ESE Duration
150	50	100	3 hours

### Course Level Assessment Questions

**Course Outcome 1 (CO1):** Understand the relevance and the concept of sustainability and the global initiatives in this direction

1. Explain with an example a technology that has contributed positively to sustainable development.
2. Write a note on Millennium Development Goals.

**Course Outcome 2 (CO2):** Explain the different types of environmental pollution problems and their sustainable solutions

1. Explain the 3R concept in solid waste management?
2. Write a note on any one environmental pollution problem and suggest a sustainable solution.
3. In the absence of green house effect the surface temperature of earth would not have been suitable for survival of life on earth. Comment on this statement.

**Course Outcome 3(CO3):** Discuss the environmental regulations and standards

1. Illustrate Life Cycle Analysis with an example of your choice.
2. “Nature is the most successful designer and the most brilliant engineer that has ever evolved”. Discuss.

**Course Outcome 4 (CO4):** Outline the concepts related to conventional and non-conventional energy

1. Suggest a sustainable system to generate hot water in a residential building in tropical climate.
2. Enumerate the impacts of biomass energy on the environment.

**Course Outcome 5 (CO5):** Demonstrate the broad perspective of sustainable practices by utilizing engineering knowledge and principles

1. Suggest suitable measures to make the conveyance facilities used by your institution sustainable.

### Model Question paper

#### Part A

(Answer all questions. Each question carries 3 marks each)

1. Define sustainable development.
2. Write a short note on Millennium Development Goals.
3. Describe carbon credit.
4. Give an account of climate change and its effect on environment.
5. Describe biomimicry? Give two examples.
6. Explain the basic concept of Life Cycle Assessment.
7. Name three renewable energy sources.

8. Mention some of the disadvantages of wind energy.
9. Enlist some of the features of sustainable habitat.
10. Explain green engineering.

**Part B**

**(Answer one question from each module. Each question carries 14 marks)**

11. Discuss the evolution of the concept of sustainability. Comment on its relevance in the modern world.  
OR
12. Explain Clean Development Mechanism.
13. Explain the common sources of water pollution and its harmful effects.  
OR
14. Give an account of solid waste management in cities.
15. Explain the different steps involved in the conduct of Environmental Impact Assessment.  
OR
16. Suggest some methods to create public awareness on environmental issues.
17. Comment on the statement, "Almost all energy that man uses comes from the Sun".  
OR
18. Write notes on:
  - a. Land degradation due to water logging.
  - b. Over exploitation of water.
19. Discuss the elements related to sustainable urbanisation.  
OR
20. Discuss any three methods by which you can increase energy efficiency in buildings.

## Syllabus

Sustainability- need and concept, technology and sustainable development-Natural resources and their pollution, Carbon credits, Zero waste concept. Life Cycle Analysis, Environmental Impact Assessment studies, Sustainable habitat, Green buildings, green materials, Energy, Conventional and renewable sources, Sustainable urbanization, Industrial Ecology.

### Module 1

Sustainability: Introduction, concept, evolution of the concept; Social, environmental and economic sustainability concepts; Sustainable development, Nexus between Technology and Sustainable development; Millennium Development Goals (MDGs) and Sustainable Development Goals (SDGs), Clean Development Mechanism (CDM).

### Module 2

Environmental Pollution: Air Pollution and its effects, Water pollution and its sources, Zero waste concept and 3 R concepts in solid waste management; Greenhouse effect, Global warming, Climate change, Ozone layer depletion, Carbon credits, carbon trading and carbon foot print, legal provisions for environmental protection.

### Module 3

Environmental management standards: ISO 14001:2015 frame work and benefits, Scope and goal of Life Cycle Analysis (LCA), Circular economy, Bio-mimicking, Environment Impact Assessment (EIA), Industrial ecology and industrial symbiosis.

### Module 4

Resources and its utilisation: Basic concepts of Conventional and non-conventional energy, General idea about solar energy, Fuel cells, Wind energy, Small hydro plants, bio-fuels, Energy derived from oceans and Geothermal energy.

### Module 5

Sustainability practices: Basic concept of sustainable habitat, Methods for increasing energy efficiency in buildings, Green Engineering, Sustainable Urbanisation, Sustainable cities, Sustainable transport.

## Reference Books

1. Allen, D. T. and Shonnard, D. R., Sustainability Engineering: Concepts, Design and Case Studies, Prentice Hall.
2. Bradley. A.S; Adebayo,A.O., Maria, P. Engineering applications in sustainable design and development, Cengage learning
3. Environment Impact Assessment Guidelines, Notification of Government of India, 2006
4. Mackenthun, K.M., Basic Concepts in Environmental Management, Lewis Publication, London, 1998
5. ECBC Code 2007, Bureau of Energy Efficiency, New Delhi Bureau of Energy Efficiency Publications-Rating System, TERI Publications - GRIHA Rating System
6. Ni bin Chang, Systems Analysis for Sustainable Engineering: Theory and Applications, McGraw-Hill Professional.
7. Twidell, J. W. and Weir, A. D., Renewable Energy Resources, English Language Book Society (ELBS).
8. Purohit, S. S., Green Technology - An approach for sustainable environment, Agrobios Publication

## Course Contents and Lecture Schedule

No	Topic	No. of Lectures
1	Sustainability	
1.1	Introduction, concept, evolution of the concept	1
1.2	Social, environmental and economic sustainability concepts	1
1.3	Sustainable development, Nexus between Technology and Sustainable development	1
1.4	Millennium Development Goals (MDGs) and Sustainable Development Goals (SDGs)	1
1.5	Clean Development Mechanism (CDM)	1
2	Environmental Pollution	
2.1	Air Pollution and its effects	1
2.2	Water pollution and its sources	1
2.3	Zero waste concept and 3 R concepts in solid waste management	1
2.4	Greenhouse effect, Global warming, Climate change, Ozone layer depletion	1
2.5	Carbon credits, carbon trading and carbon foot print.	1
2.6	Legal provisions for environmental protection.	1
3	Environmental management standards	
3.1	Environmental management standards	1
3.2	ISO 14001:2015 frame work and benefits	1
3.3	Scope and Goal of Life Cycle Analysis (LCA)	1
3.4	Circular economy, Bio-mimicking	1
3.5	Environment Impact Assessment (EIA)	1
3.6	Industrial Ecology, Industrial Symbiosis	1
4	Resources and its utilisation	
4.1	Basic concepts of Conventional and non-conventional energy	1
4.2	General idea about solar energy, Fuel cells	1
4.3	Wind energy, Small hydro plants, bio-fuels	1
4.4	Energy derived from oceans and Geothermal energy	1
5	Sustainability Practices	
5.1	Basic concept of sustainable habitat	1
5.2	Methods for increasing energy efficiency of buildings	1
5.3	Green Engineering	1
5.4	Sustainable Urbanisation, Sustainable cities, Sustainable transport	1

CEL 201	CIVIL ENGINEERING PLANNING & DRAFTING LAB	CATEGORY	L	T	P	CREDIT	YEAR OF INTRODUCTION
		PCC	0	0	3	2	2019

**Preamble:** The course is designed to introduce the fundamentals of Civil Engineering drawing and understand the principles of planning. The students will be able to learn the drafting of buildings manually and using drafting software such as AutoCAD.

**Prerequisite:** ENGINEERING GRAPHICS

**Course Outcomes and their assessment:** After the completion of the course, the student will be able to:

Course Outcome (CO)	Course Outcome Description	CO assessment strategy
CO 1	Illustrate ability to organise civil engineering drawings systematically and professionally	Assessment of the overall organisation of the drawing, labels and templates used.
CO 2	Prepare building drawings as per the specified guidelines.	Application of guidelines for functional planning of building unit.
CO 3	Assess a complete building drawing to include all necessary information	Level of incorporation of Guidelines specified by NBC, meeting the requirement of building rules specified by local bodies of administration.
CO 4	Create a digital form of the building plan using any drafting software	Evaluation of the printouts of prepared building plan

**Mapping of course outcomes (COs) with program outcomes (POs)**

CO/PO	PO 1	PO 2	PO 3	PO 4	PO 5	PO 6	PO 7	PO 8	PO 9	PO 10	PO 11	PO 12
CO 1	3	-	-	-	-	-	-	2	3	3	-	-
CO 2	3	-	-	-	-	-	-	2	3	3	-	-
CO 3	3	-	-	-	-	-	-	2	3	3	-	-
CO 4	3	-	-	-	-	-	-	2	2	3	-	-

**List of Experiments (Any 12 experiments out of 15 need to be performed mandatorily. Manual drafting and drafting using computer aided drafting software is mandatory for the experiments)**

1. Draw sectional details and elevation of paneled doors
2. Draw sectional details and elevation of glazed windows and ventilators in wood.
3. Draw sectional details , detailing on fixing arrangement and elevation of steel windows.
4. Draw elevation, section and detailing of connection between members, arrangement for fixing at the support for steel roof truss.
5. Draw plan, section and elevation of dog legged staircase.
6. Draw sectional details of a load bearing wall over strip footing, RCC Column over isolated footing and pile footing with pile cap.
7. Draw plan, section and elevation of single storied residential buildings with flat roof.
8. Draw plan, section and elevation of two storied residential building.
9. Draw plan , section and elevation of a community hall having corrugated GI sheet roof.
10. Prepare a site plan and service plan as per latest building rules (KPBR or KMBR)
11. Prepare detailed drawing on building services (for single and two storied buildings only) and on-site wastewater disposal systems like septic tank and soak pit.
12. Draw plan, section and elevation of multi-storied framed buildings.
13. Draw plan, section and elevation of a public buildings—office complex, public health centre, post office, bank etc
14. Draw plan, section and elevation of a industrial building with corrugated GI steel roof and PEB based walling elements.
15. Create 3D model of a two storied residential building and render the model.

**References**

- 1.** National Building Code of India
- 2.** Kerala panchayat building rules, 2019
- 3.** Kerala Municipality building rules, 2019
- 4.** Dr. Balagopal T.S. Prabhu, Building Drawing and Detailing, Spades Publishers, Calicut
- 5.** AutoCAD Essentials, Autodesk official Press, John Wiley & Sons, USA
- 6.** Shah, M.G., Kale, C. M. and Patki, S.Y. Building Drawing With An Intergrated Approach to Built Environment, Tata McGraw Hill Publishing Company Limited, New Delhi

**Mark distribution**

Total Marks	CIE	ESE	ESE Duration
150	75	75	2.5 hours

**Continuous Internal Evaluation Pattern:**

Marks for 12 exercises using manual drafting in A4 Paper : **50 marks**

Marks for 12 exercises using computer aided drafting software in A3/A4 paper: **25 marks**



COs	Assessment Strategy	Marking Criteria	Marks
CO 1	Assessment of the overall organisation of the drawing, labels and templates used.	Marks to be awarded based on the initial preparations displayed in manual drawing	10
CO 2	Application of guidelines for functional planning of building unit.	Marks to be awarded based on the prepared plan of the building	20
CO 3	Level of incorporation of Guidelines specified by NBC, meeting the requirement of building rules specified by local bodies of administration.	Marks to be awarded based on the checklists of assessment for the prepared plan of the building	20
CO 4	Evaluation of the printouts of prepared building plan	Marks to be awarded based on the printout of the final plan of the building	25

**End Semester Examination Pattern:** ESE will be of **2.5 hours** duration on A2 size answer booklet and will be for 75 marks. (only manual drafting for ESE)



CEL 203	SURVEY LAB	CATEGORY	L	T	P	CREDIT
		PCC	0	0	3	2

**Preamble:**

Objective of the course is to impart practical experience to students by exposing them to various techniques of field surveying. The course is designed to make student familiar with conventional and advanced surveying instruments.

**Prerequisite:** Nil

**Course Outcomes:** After the completion of the course, the student will be able to:

CO 1	Use conventional surveying tools such as chain/tape and compass for plotting and area determination.
CO 2	Apply levelling principles in field
CO 3	Solve triangulation problems using theodolite
CO 4	Employ total station for field surveying
CO 5	Demonstrate the use of distomat and handheld GPS

**Mapping of course outcomes with program outcomes**

	PO 1	PO 2	PO 3	PO 4	PO 5	PO 6	PO 7	PO 8	PO 9	PO 10	PO 11	PO 12
CO 1	3							1	2			
CO 2	3			1				1	2			
CO 3	3			1				1	2			
CO 4	3			1	3			1	2			2
CO 5	3				3			1				2

**Course Level Assessment Questions**

**Course Outcome 1 (CO1):** Plot the given area using chain/tape and compass and compute its area.

**Course Outcome 2 (CO2):** Determine the reduced levels of the given points in the field with respect to the Bench Mark of RL=100.00

**Course Outcome 3 (CO3):** Find out the distance between two inaccessible points A and B. Baseline measurement is allowed.

**Course Outcome 4 (CO4):** Compute the area of a given plot using total station.

**Course Outcome 5 (CO5):** Explain the parts of a handheld GPS with neat sketch.

**Assessment Pattern**

Bloom's Category	Continuous Assessment	End Semester Examination (marks)
Remember	10	15
Understand	10	15
Apply	40	40
Analyse		
Evaluate		
Create		

**Mark Distribution**

Total Marks	CIE (Marks)	ESE (Marks)	ESE Duration
150	75	75	2.5 hours

**Continuous Internal Evaluation (CIE) Pattern**

Attendance	:	15 marks
Continuous Assessment	:	30 marks
Internal Test (Immediately before the second series test)	:	30 marks

**End Semester Examination (ESE) Pattern:**

Practical examination shall include problems on leveling/theodolite and total station with equal mark distribution. The following guidelines should be followed regarding award of marks

- |  |   |          |
|--|---|----------|
| (a) Preliminary work   | : | 15 Marks |
| (b) Implementing the work/Conducting the experiment                              | : | 10 Marks |
| (c) Performance, result and inference (usage of equipments and trouble shooting) | : | 25 Marks |
| (d) Viva voce  | : | 20 marks |
| (e) Record   | : | 5 Marks  |

**General instructions:**

Practical examination to be conducted immediately after the second series test covering entire syllabus given below. Evaluation is a serious process that is to be conducted under the equal responsibility of both the internal and external examiners. The number of candidates evaluated per day should not exceed 20. Students shall be allowed for the University examination only on submitting the duly certified record. The external examiner shall endorse the record.

## Syllabus

List of Exercises/ Experiments:

1. Introduction to conventional surveying - 1 session
2. Levelling - 4sessions
3. Theodolite surveying - 5sessions
4. Total Station survey - 4sessions
5. Study of instruments - 1 session
  - Automatic level
  - digital level
  - Handheld GPS

**Course Content and Practical Schedule (Any twelve experiments are mandatory):**

Expt. No.	List of exercises/experiments	Course Outcome	No. of Hrs
1	<b>Introduction to conventional surveying</b> a. Chain surveying b. Compass surveying	CO1	3
2	<b>Levelling</b> Simple leveling	CO2	3
3	Differential levelling		3
4	Fly levelling		3
5	Contouring		3
6	<b>Theodolite surveying</b> Distance between accessible points (horizontal angle)		CO3
7	Distance between inaccessible points (horizontal angle)	3	
8	Level difference between points (vertical angle)	3	
9	Tangential tacheometry (vertical angle)	3	
10	Height of building (vertical angle)	3	
11	<b>Total station survey</b> Heights and distances	CO4	3
12	Area computation		3
13	Contouring		3
14	Downloading		3
15	<b>Study of instruments</b> a. Automatic level b. Digital level c. Handheld GPS	CO5	3

### Reference Books

1. Dr. B.C. Punmia , Ashok Kumar Jain & Arun Kumar Jain - Surveying , Laxmi publications (P) Ltd , 2005
2. C. Venkatramaiah, Textbook of Surveying, Universities Press (India) Private Limited 2011

3. Prof. T.P.Kenetkar&Prof.S.V.Kulkarni - Surveying and Levelling , Pune VidyarthiGriha Prakashan,2004
4. R.Agor - A Text book of Surveying and Levelling, Khanna Publishers, 2005
5. S.K.Duggal - Surveying Vol. I, Tata McGraw Hill Ltd ,Reprint 2015.
6. S.K. Duggal - Surveying Vol. II, Tata McGraw Hill Ltd ,Reprint 2015

